

## Summary of amendments between ES-TRIN 2023/1 and 2025/1

This summary is published for information purposes only. In the event of differences, only the published editions of ESTRIN 2023/1 and 2025/1 (including any corrigenda) are authentic.

Additions and changes are highlighted in grey. Deletions are highlighted in blue.

1. *The table of contents is amended as follows:*

a) *The note relating to Article 11.09 is deleted:*

~~“Article 11.09 Electric auxiliary propulsion with power electronics”.~~

b) *The note relating to Article 18.09 is worded as follows:*

“Article 18.09 Installation and performance test ~~Random sample measurement / Special test”.~~

c) *The note relating to Article 18.09 becomes the note relating to Article 18.10 as follows:*

“Article 18.10 Random sample measurement / Special test ~~Competent authorities and technical services”.~~

d) *The note relating to Article 18.11 is added after the note relating to Article 18.10 as follows:*

“Article 18.11 Operation management manual and instructions”.

e) *The note relating to Article 27.02 (concerns only the French version)*

f) *The note relating to Annex 6 is worded as follows:*

“ANNEX 6 (LEFT VOID)”.

g) *The note relating to Annex 7, Section VIII, is worded as follows:*

“Section VIII Test report for ~~On-board sewage treatment plants~~ ~~parameters record for special test”.~~

h) *The note relating to ESI-II-14 is added after the note relating to ESI-II-13 as follows:*

“ESI-II-14 COLOUR CODING FOR FILLER NECKS”.

i) *The note relating to ESI-III-12 is added after the note relating to ESI-III-11 as follows:*

“ESI-III-12 ARRANGEMENTS OF METHANOL FUEL TANKS”

2. Article 1.01 is amended as follows:

a) (3.2) (concerns only the French version)

b) (3.4) is worded as follows:

“3.4 ‘electrical service room’ a room in which components of an electric propulsion system such as control cabinets or electric engines are located, and which is not an ~~main engine room or~~ engine room;”.

c) (3.7) is worded as follows:

“3.7 ‘accommodation’: a space intended for the use of persons normally living on board, including galleys, toilets and washrooms ~~ing facilities~~, laundries ~~y facilities~~, passageways, but not the wheelhouse;”.

d) (3.8) (concerns only the French, German and Dutch version)

e) (4.7) is worded as follows:

“4.7 ‘water displacement’ or ‘v’: the immersed volume of the vessel, in m<sup>3</sup>, in water with a density of 1000 kg/m<sup>3</sup>;”.

f) (4.27) to (4.29) below are added after (4.26) as follows:

“4.27 (left void);

4.28 ‘lightship waterline’: the waterline corresponding to the lightship displacement;

4.29 ‘fixed height’: the vertical distance in m between the lightship waterline of the craft and the highest point of the craft after all mobile installations (elevating wheelhouse, radar installations, foldable masts etc.) have been brought to their lowest positions;”.

g) (5.11) is worded as follows:

“5.11 ~~wheelhouse~~ steering position designed for radar navigation by one person’: a ~~wheelhouse~~ steering position arranged in such a way that, during radar navigation, the vessel can be manoeuvred by one person;”.

h) (6.9) hereafter is added after (6.8) as follows:

“6.9 ‘fire-restricting’: the property of structural components or devices as certified by the test procedure referred to in Article 19.11(1)(e);”.

i) (7.2) (concerns only the French version)

j) (7.5) to (7.9) are worded as follows:

“7.5 ‘Inland ECDIS equipment’: equipment fitted aboard a vessel and used within the meaning of the current edition of ES-RIS, part II ~~Inland ECDIS Standard~~. It can be operated in two different modes: information mode and navigation mode;

7.6 ‘information mode’: use of Inland ECDIS equipment for information purposes only without radar overlay;

7.7 ‘navigation mode’: use of Inland ECDIS equipment with radar overlay for navigating a craft;

7.8 ‘Inland AIS equipment’: equipment fitted aboard a vessel and used within the meaning of the current edition of ES-RIS, part II ~~VTT Standard~~;

7.9 ‘ES-RIS’: the European Standard for River Information Services (ES-RIS 2025/1)<sup>1</sup>; ~~VTT Standard~~; ‘Vessel Tracking and Tracing Standard for Inland Navigation’ in accordance with the technical specifications defined by part II of the European Standard for River Information Services ES-RIS 2023/1<sup>2</sup>”.

k) (7.10) to (7.12) are deleted.

~~“7.10 ‘Inland ECDIS Standard’: ‘Electronic Chart Display and Information System Standard for Inland Navigation’ in accordance with the technical specifications defined by part I of the European Standard for River Information Services ES-RIS 2023/1;~~

~~7.11 ‘Test Standard for Inland AIS’: ‘Test Standard Inland AIS’ in accordance with the technical specifications defined by part VI of the European Standard for River Information Services ES-RIS 2023/1;~~

~~7.12 ‘Test Standard for Inland ECDIS’: ‘Test Standard Inland ECDIS’ in accordance with the technical specifications defined by part V of the European Standard for River Information Services ES-RIS 2023/1.”~~

3. Article 5.05(1) is worded as follows:

“1. During the navigation test, all of the equipment referred to in items 34 and 52 of the inland navigation vessel certificate which may be actuated from the ~~wheelhouse~~ steering position may be used, apart from anchors.”

4. Article 6.06(1), 1<sup>st</sup> paragraph, is worded as follows:

“1. Where the thrust vectoring of rudder-propeller, water-jet, cycloidal-propeller or bow thruster installations is remotely actuated by electric, hydraulic or pneumatic means, there shall be two steering controls, each independent of the other, between the ~~wheelhouse~~ steering position and the propeller- or thruster-installation which, *mutatis mutandis*, meet the requirements of Articles 6.01 to 6.05.”

<sup>1</sup> CESNI Resolution 2024-II-2 dated 17 October 2024.

<sup>2</sup> European Standard for River Information Services (ES-RIS 2023/1); CESNI Resolution 2022-II-12 dated 13 October 2022.

5. *Article 6.07 is worded as follows:*

**“Article 6.07  
Indicators and monitoring devices**

~~1. The rudder position shall be clearly displayed at the steering position. If the rudder-position indicator is electric it shall have its own power supply.~~

~~2. An optical and acoustic alarm shall be present at the steering position to signal the following:~~

~~a) oil level of the hydraulic tanks falling under the lowest content level in accordance with Article 6.03(2) and decrease of service pressure of the hydraulic system;~~

~~b) failure of the electrical supply for the steering control;~~

~~c) failure of the electrical supply for the drive units;~~

~~d) failure of the rate-of-turn regulator;~~

~~e) failure of the required buffer devices.”~~

6. *Article 6.09(4)(e) (concerns only the French version)*

7. *Article 7.01(3) is worded as follows:*

“3. Where a ~~wheelhouse~~ steering position has been designed for radar navigation by one person, the helmsman shall be able to accomplish his task while seated and all of the display or monitoring instruments and all of the controls needed for operation of the vessel shall be arranged in such a way that the helmsman may use them comfortably while the vessel is under way without leaving his position or losing sight of the radar screen.”

8. *Article 7.03(6) and (7) (concerns only the French version)*

9. *Article 7.04 is worded as follows:*

**“Article 7.04  
Specific requirements concerning control, indicating and monitoring equipment of  
main engines and steering systems**

1. It shall be possible to control and monitor the main engines and steering systems from the steering position. Main engines fitted with a clutch which can be actuated from the steering position, or driving a controllable pitch propeller which can be controlled from the steering position, need only to be capable of being started up and shut down from the engine room.

2. The control for each main engine shall take the form of a single lever which prescribes an arc within a vertical plane that is approximately parallel to the longitudinal axis of the vessel. Movement of that lever towards the bow of the vessel shall cause forward motion, whereas movement of the lever towards the stern shall cause the vessel to go astern. Clutch engagement and reversal of the direction of motion shall take place about the neutral position of that lever. The lever shall catch in the neutral position.

3. ~~The direction of the propulsion thrust imparted to the vessel and the rotational speed of the propeller or main engines shall be displayed.~~ (left void)

4. The indicating, monitoring and alarm devices required by (10) and (11), shall be located at the steering position. ~~The indicating and monitoring devices required by Article 6.07(2), Article 8.03(2), and Article 8.05(13), shall be located at the steering position.~~

5. Vessels with ~~wheelhouses~~ steering positions designed for radar navigation by one person shall be steered by means of a lever. It shall be possible to move that lever easily by hand. The position of the lever in relation to the longitudinal axis of the vessel shall correspond precisely to the position of the rudder blades. It shall be possible to release hold of the lever in any given position without that of the rudder blades changing. The neutral position of the lever shall be clearly perceptible.

6. Where the vessel is fitted with bow rudders or special rudders, particularly for going astern, these shall be actuated in ~~wheelhouses~~ steering positions designed for radar navigation by one person by special levers which, *mutatis mutandis*, meet the requirements set out in (5).

That requirement shall also apply where, in convoys, the steering system fitted to craft other than those powering the convoy is used.

7. Where rate-of-turn regulators are used, it shall be possible for the rate-of-turn control to be released in any given position without altering the speed selected.

The control shall turn through a wide enough arc to guarantee adequately precise positioning. The neutral position shall be clearly perceptible from the other positions. It shall be possible to increase or decrease the level of illumination.

8. The remote-control equipment for the entire steering system shall be installed in a permanent manner and be arranged in such a way that the course selected is clearly visible. If the remote control equipment can be disengaged, it shall be equipped with an indicating device displaying the respective operational conditions 'in service' or 'out of service'. The disposition and manipulation of the controls shall be functional.

For systems that are subsidiary to the steering system, such as active bow thrusters, remote-control equipment not permanently installed shall be acceptable provided that such a subsidiary installation can be activated by means of an override at any time within the wheelhouse.

9. In the case of rudder-propeller, water-jet, cycloidal-propeller and bow-thruster systems, equivalent devices shall be acceptable as control, indicating and monitoring devices.

The requirements set out in (1) to (8) shall apply, *mutatis mutandis*, in view of the specific characteristics and arrangements selected for the abovementioned active steering and propulsion units. In analogy to (2), each unit shall be controlled by a lever which moves in the form of an arc within a vertical plane that is approximately parallel to the direction of the thrust of the unit. From the position of the lever the direction of the thrust acting on the vessel shall be clear

If rudder propeller or cycloidal-propeller systems are not controlled by means of levers, the inspection body may allow derogations from (2). These derogations shall be entered in item 52 of the inland navigation vessel certificate.

10. At least the following parameters shall be monitored at the steering position by suitable devices, where relevant for the corresponding propulsion system:
  - a) the characteristic operational temperature of the propulsion engines (e.g. temperature of the coolant of combustion engines or externally cooled electric engines, temperature of windings or bearings of electric engines);
  - b) the lubricating-oil pressure for the propulsion engines and transmissions;
  - c) the oil and air pressure of the reversing units of the propulsion engines, reversible transmissions or propellers;
  - d) the rotational speed of the propulsion engines;
  - e) the rotational speed of the propulsors;
  - f) the direction of thrust imparted to the vessel by the propulsors;
  - g) the level of available fuel in fuel tanks (filling level) or energy in accumulator sets (state of charge) supplying propulsion engines.
  
11. An acoustic and optical alarm pursuant to Article 7.03(5) to (7) shall be triggered at the steering position once a critical level has been reached or a failure has been detected. An alarm shall be triggered at least for the following parameters or functions, where relevant for the corresponding propulsion system:
  - a) the characteristic operational temperature or a failure of the cooling system of the propulsion engines and ancillary installations essential for the operation of the propulsion engines (e.g. power electronics),
  - b) the lubricating-oil pressure for the propulsion engines and transmissions;
  - c) the oil and air pressure of the reversing units of the propulsion engines, reversible transmissions and propellers;
  - d) the rotational speed of the propulsion engines;
  - e) the level of available fuel in fuel tanks (filling level) or energy in accumulator sets (state of charge) supplying propulsion engines;
  - f) oil level of the hydraulic tanks falling under the lowest content level in accordance with Article 6.03(2) and decrease of service pressure of the hydraulic system;
  - g) failure of the electrical supply for the steering control;
  - h) failure of the electrical supply for the electric propulsion system;
  - i) failure of the rate-of-turn regulator;
  - j) failure of the required buffer devices;
  - k) imminent activation of an overload protection in accordance with Article 11.04(2);
  - l) activation of protective devices in accordance with Article 11.07; and
  - m) power limitation in accordance with Article 11.06.

A critical level for (a) and (e) shall be corresponding to the capability of the vessel for making steerageway under its own power for at least 30 minutes.”

10. *Article 7.05(3) and (4) are worded as follows:*

“3. In wheelhouses steering positions designed for radar navigation by one person, repeater lights shall be installed on the control panel in order to monitor the navigation lights and the light signals. Switches of navigation lights shall be included in the repeater lights or be adjacent to these and shall be clearly assigned to them.

The arrangement and colour of the repeater lights for the navigation lights and light signals shall correspond to the actual position and colour of those lights and signals.

The failure of a navigation light or light signal to function shall cause the corresponding repeater light either to go out or to provide a signal in another manner.

4. In wheelhouses steering positions designed for radar navigation by one person it shall be possible to activate the sound signals by a foot operated switch. That requirement shall not apply to the ‘do not approach’ signal in accordance with the applicable navigational authority regulations of the Member States.”

11. *Article 7.06(2) and (3) are worded as follows:*

“2. Inland ECDIS equipment which can be operated in navigation mode shall be regarded as navigational radar installation. It shall meet the requirements of ES-RIS, parts I and V the Inland ECDIS Standard and the Test Standard for Inland ECDIS. The requirements of Annex 5 must be complied with.

3. Inland AIS equipment shall meet the requirements of ES-RIS, parts II and VI the current Test Standard for Inland AIS. The requirements of Annex 5 must be complied with.”

12. *Article 7.06(5) is worded as follows:*

“5. In wheelhouses steering positions designed for radar navigation by one person:

- a) the radar screen shall not be shifted significantly out of the helmsman's axis of view in its normal position;
- b) the radar image shall continue to be perfectly visible, without a mask or screen, whatever the lighting conditions outside the wheelhouse;
- c) the rate-of-turn indicator shall be installed directly above or below the radar image or be incorporated into this.”

13. *Article 7.07 is worded as follows:*

**“Article 7.07**

***Radio telephony systems for vessels with wheelhouses steering positions designed for radar navigation by one person***

1. Where vessel wheelhouses steering positions have been designed for radar navigation by one person, reception from the vessel to vessel networks and that of nautical information shall be via a loudspeaker, and outgoing communications via a fixed microphone. Send/receive shall be selected by means of a push-button.

It shall not be possible to use the microphones of those networks for the public correspondence network.

2. Where vessel wheelhouses steering positions designed for radar navigation by one person are equipped with a radio telephone system for the public correspondence network, reception shall be possible from the helmsman's seat.”

14. Article 7.08, 1<sup>st</sup> sentence, is worded as follows:

“There shall be internal communication facilities on board vessels with a wheelhouse steering position designed for radar navigation by one person.”

15. Article 7.11 is worded as follows:

**“Article 7.11  
Stern-anchor operating equipment**

On board vessels and convoys whose wheelhouse steering position has been designed for radar navigation by one person and exceeding 86 m in length or 22,90 m in breadth it shall be possible for the helmsman to drop the stern anchors from his position.”

16. Article 7.12 is worded as follows:

**“Article 7.12  
Elevating wheelhouses**

1. A mechanically powered elevating wheelhouse and its appliances shall be designed in such a way that the safety of persons on board is not endangered.
2. An elevating wheelhouse shall not endanger the stability of the vessel.
3. The strength of the elevating wheelhouse, of the lifting mechanism and the associated vessel parts must be adequately dimensioned in accordance with good shipbuilding practice.
34. Operations carried out from the wheelhouse shall not be hindered during lifting and lowering. It shall be possible to enter and leave the wheelhouse safely, whatever its position. A roof opening may be used as an emergency exit, provided that it complies with the dimensions in Article 14.06(2).
45. It shall be possible to operate the lifting mechanism from inside the wheelhouse. The following indications shall be arranged at the steering position:
  - a) voltage present,
  - b) wheelhouse in lowest position,
  - c) wheelhouse in highest position,
  - d) wheelhouse locked in fixed position (if applicable).
56. The lifting mechanism shall enable the wheelhouse to stop in all positions. If the possibility exists to lock the wheelhouse in a certain position, the lifting mechanism shall be automatically disabled when locking takes place. Releasing the locks shall be possible under all operating conditions.
67. The lifting mechanism shall be designed in such a way that exceeding the terminal positions is not possible.
78. Arrangements shall be provided to avoid uncontrolled lowering of the wheelhouse. Appropriate protection features shall be installed to prevent the risk of injury which may result from lowering. Accesses to the lifting device shall be marked with the symbol shown in Annex 4, Figure 1, and equipped with a warning device that triggers an optical and acoustic warning signal in the wheelhouse. All lowering operations shall automatically trigger an optical and a clearly audible acoustic warning signal.



89. Elevating wheelhouses shall be fitted with an emergency lowering system, which is independent from the normal lifting mechanism and can be used even in the event of a power failure of the energy supply. This emergency system shall be operated from inside the wheelhouse. When using the emergency system the lowering speed shall not be less than the lowering speed under normal conditions.

910. (left void)

1011. Hydraulic hoses are:

- a) only permissible, if vibration absorption or freedom of movement of components makes their use inevitable;
- b) to be designed for at least the maximum service pressure;
- c) to be renewed at the latest every eight years.

1112. Elevating wheelhouses and their appliances shall be inspected regularly, but at least once every twelve months, by a competent person. The safety of the installation is to be established by a visual check and a check on satisfactory operation.

~~12. Elevating wheelhouses and their appliances shall be inspected by an expert:~~

- ~~a) before being put into service for the first time,~~
- ~~b) before being put back into service after any major modification or repair, and~~
- ~~c) regularly, at least every five years.~~

~~In these inspections proof of adequate strength and stability shall be provided by calculations.~~

~~An inspection attestation shall be issued, signed by the expert and showing the date of the inspection."~~

17. Article 7.13 is worded as follows:

**"Article 7.13**

**Entry in the inland navigation vessel certificate for vessels with wheelhouses steering positions designed for radar navigation by one person**

Where a vessel complies with the special provisions for wheelhouses steering positions designed for radar navigation by one person as set out in Articles 7.01(3), 7.04(5) and (6), 7.05(3) and (4), 7.06(2), 7.07, 7.08 and 7.11, the following entry shall be made in the inland navigation vessel certificate:

'The vessel has a wheelhouse steering position designed for radar navigation by one person'.

18. Article 7.14(6) (concerns only the French version)

19. Article 8.01 is amended as follows:

a) (2)(b) (concerns only the French version)

b) (4) is worded as follows:

“4. By way of derogation from (3), craft may be equipped with propulsion or auxiliary systems operating on the following fuels with a flashpoint equal to or lower than 55 °C; ~~if they fulfil the requirements of Chapter 30 and Annex 8 or are outside the scope of application of Chapter 30.~~

- a) liquefied natural gas (LNG),
- b) methanol and
- c) gaseous hydrogen.

For propulsion or auxiliary systems operating these fuels the requirements of Chapter 30 and Annex 8 of this Standard shall apply.”

20. Article 8.02(4) (concerns only the Dutch version)

21. Article 8.03 is worded as follows:

### **“Article 8.03 Propulsion systems**

1. It shall be possible to start, stop or reverse the ship's propulsion reliably and quickly.

~~2. The following areas shall be monitored by suitable devices which trigger an alarm once a critical level has been reached:~~

- ~~a) the temperature of the cooling water of the main engines;~~
- ~~b) the lubricating oil pressure for the main engines and transmissions;~~
- ~~c) the oil and air pressure of the reversing units of the main engines, reversible transmissions or propellers.~~

23. Where vessels have only one propulsion engine, that engine shall not be shut down automatically except in order to protect against overspeed.

34. Where vessels have only one propulsion engine, that engine may be equipped with an automatic device for the reduction of the engine speed only if an automatic reduction of the engine speed is indicated both optically and acoustically in the wheelhouse and the device for the reduction of the engine speed can be switched off from the ~~helmsman's~~ steering position.

45. Shaft bushings shall be designed in such a way as to prevent the spread of water-polluting lubricants.”

22. Article 8.05 is amended as follows:

a) (5) is worded as follows:

“5. The filler orifices for fuel tanks shall be marked distinctly and the filler necks shall be suitably labelled in colour. This requirement is deemed to be fulfilled if the requirements of the international standard ISO 14726 : 2008 are met.”

b) (7) is worded as follows:

“7. Directly at tank outlets the pipework for the distribution of liquid-fuels shall be fitted with a quick-closing valve that can be operated from the deck, even when the spaces/rooms in question are closed.

If the operating device is concealed, the lid or cover shall not be lockable.

The operating device shall be marked in red. If the device is concealed it shall be marked with a symbol for the 'quick-closing valve on the tank' in accordance with Figure 9 of Annex 4 with a side length of at least 10 cm.

The first subparagraph shall not apply to fuel tanks mounted directly on the engine.”

c) (11), 2<sup>nd</sup> sentence, is worded as follows:

“If the sensor activates an electrical contact, which can break the circuit provided by the bunkering station by a binary signal, it shall be possible to transmit the signal to the bunkering station by means of a watertight connection plug meeting the requirements of International Standard IEC 60309-1 : 2012 2021 for 40 to 50 V DC, housing colour white, earthing contact position ten o'clock.”

d) (13) is deleted:

~~“13. Fuel tanks directly supplying the propulsion engines and engines needed for navigation shall be fitted with a device emitting both visual and audible signals in the wheelhouse if their level of filling is not sufficient to ensure further safe operation.”~~

23. Article 8.06 is amended as follows:

a) A new (5) is inserted as follows:

“5. The filler neck shall be fitted with a connection piece in accordance with the European standard EN 14420-7 : 2022. The male side of the connection piece shall be placed on the vessel and have a diameter DN 40. A blind coupling in accordance with the standard must be available for closing.”

b) The present (5) is renumbered as (6) and is worded as follows:

“6. The filler orifices for lubricating oil tanks shall be marked distinctly and the filler necks shall be suitably labelled in colour. This requirement is deemed to be fulfilled if the requirements of the international standard ISO 14726 : 2008 are met.”

c) The current (6) and (7) become (7) and (8).

24. Article 8.07(5) is worded as follows:

“5. The filler orifices for oil tanks according to (1) shall be marked distinctly and the filler necks shall be suitably labelled in colour. This requirement is deemed to be fulfilled if the requirements of the international standard ISO 14726 : 2008 are met.”

25. Article 9.00 is amended as follows:

a) (5) is worded as follows:

“5. ‘engine manufacturer’: any natural or legal person who is responsible to the approval authority for all aspects of the engine type-approval or authorisation process and for ensuring conformity of engine production, and who is also responsible for market surveillance concerns for the engines produced, whether or not they are directly involved in all stages of the design and construction of the engine which is the subject of the type-approval process.”

b) (6) is deleted:

~~“6. ‘engine parameter protocol’: the document pursuant to Annex 6, in which all the parameters, together with changes, and including components and engine settings which affect the level of emission of gaseous and particulate pollutants from the engine are duly recorded.”~~

26. Article 9.01 is amended as follows:

a) (3) is worded as follows:

“3. The inspection body may require presentation of the type-approval certificate and engine manufacturer's instructions as per Article 9.04 upon each installation, intermediate, or special test. ~~A copy of the type-approval certificate, the engine manufacturer's instructions and the engine parameter protocol shall be kept on board.~~”

b) After (5), (6) is added as follows:

“6. By way of derogation from Articles 9.01(2) last sentence and (3), 9.02, 9.03, 9.06(2), internal combustion engines that benefit from a field test exemption granted in accordance with Article 34(4) of Regulation (EU) 2016/1628 are permitted. However, the inland navigation vessel certificate shall not be valid for longer than the duration of the field test.”

27. Article 9.02 is worded as follows:

**“Article 9.02  
Entry in the inland navigation vessel certificate**

~~The identification number, as well as the type-approval number where applicable, of~~ The following data are to be entered in item 52 of the inland navigation vessel certificate for all internal combustion engines installed ~~on board~~ aboard the craft: ~~shall be entered in item 52 of the inland navigation vessel certificate.~~

- a) Manufacturer,
- b) Engine type (manufacturer's designation),
- c) Identification number,
- d) Power and engine speed,
- e) If applicable, type-approval number,
- f) Use for which the engine is intended,
- g) Installation location on board,
- h) Date of installation.“

28. Article 9.05(1) and (2) are worded as follows:

- “1. At the time of the installation test and in the event of intermediate tests and special tests, the inspection body will inspect the current state of the engine with reference to the components, adjustments and parameters specified in the engine manufacturer's instructions ~~and the engine parameter protocol.~~
2. ~~The inspection body shall document tests conducted according to (1). The results of the tests pursuant to (1) shall be registered in the engine parameter protocol in accordance with Annex 6.“~~

29. Article 9.09 is amended as follows:

- a) (2) (concerns only the Dutch and French version)
- b) (3) (concerns only the French version)

c) (4)(b) (concerns only the French version)

d) (6) hereafter is added after (5) as follows:

"6. Exhaust gas after treatment systems not already included within the scope of the engine's type-approval are to be entered with the following data in item 52 of the inland navigation vessel certificate for the engine in question:

- a) Manufacturer,
- b) Type designation,
- c) System type."

30. Article 9.10 is amended as follows:

a) (1) is worded as follows:

"1. Engine repairs are permitted provided that:

- a) they are consistent with the type-approval and existing engine parameter protocol the engine manufacturer's instructions;
- b) the identity of that repaired engine is traceable such that the original engine that was placed on the market and installed on the vessel can be identified.

If the repairs result in the entire engine being replaced, the requirements of Article 9.01(2) shall apply. In particular, if a different identification number is assigned to the engine, it shall then be deemed to be a newly installed engine."

b) (2)(d) is worded as follows:

"d) confirmation of compliance with the engine manufacturer's instructions and the engine parameter protocol referred to in Article 9.05(1) after maintenance or repair, that subsequent to repair or maintenance, the engine's specified components, calibration, and parameter settings comply with the engine manufacturer's instructions under Article 9.04,."

31. *Article 10.01(2) is worded as follows:*

- “2. The following documents bearing the stamp of the inspection body shall be available on board:
- a) general plans concerning the entire electrical installation;
  - b) plans of the main switchboards, the emergency switchboards, the distribution switchboards, showing the most important technical data such as amperage of the nominal current of fuses and switching devices;
  - c) indications of power requirements for electrical service equipment;
  - d) types of cables indicating conductor cross-sections;
  - e) for electric vessel propulsion systems, a process and instrumentation diagram (PID) of these systems, switchboard plans, arrangement plans of electric service rooms including the location of main components as well as electric propulsion engine documentation for electric propulsion engines and other main components;
  - f) plans of electronic steering control, regulating, alarm and safety systems;
  - g) control circuit plans.

For unmanned craft, these documents shall not be required to be on board but shall at all times be available with the owner.”

32. *In Article 10.02, (4) hereafter is added after (3):*

- “4. The requirements of (1) above shall not apply to the power sources of electric propulsion systems which are subjected to Chapter 11.”

33. *In Article 10.04, (4) hereafter is added after (3):*

- “4. Hazardous areas shall bear on the outside a symbol for “Warning for areas where explosive atmospheres may occur” in accordance with Figure 13 of Annex 4, with a side length of at least 10 cm.”

34. *Article 10.11 is amended as follows:*

a) *(15) is worded as follows:*

- “15. The requirements of European Standard EN 62619 : 2017 2022 and EN 62620 : 2015 2023 shall apply for lithium-ion accumulators.”

b) *(18) is worded as follows:*

- “18. The name of the manufacturer, serial number, type and installation date of the lithium-ion accumulators shall be entered in item 52 of the inland navigation vessel certificate.”

c) *The current (18) and (19) are renumbered as (19) and (20) and are worded as follows:*

- “19. The requirements of (15), (16), and (17) and (18) do not apply to accumulators in mobile equipment or with a charging power of less than 0,2 kW.

1920. For batteries, (1) to (12) and (16) shall apply *mutatis mutandis*.”

35. *Article 10.12(3)(b) (concerns only the French version)*

36. *Article 10.14(3) is worded as follows:*

“3. Switches shall simultaneously switch all non-earthed conductors within a circuit. However, single-pole switches within non-earthed circuitry shall be permitted in accommodation-lighting circuits apart from in laundries, **bathrooms**, washrooms and other rooms with wet facilities.”

37. *Article 10.19(1) (concerns only the French version)*



38. Chapter 11 is worded as follows:

**“CHAPTER 11  
SPECIAL PROVISIONS APPLICABLE TO ELECTRIC VESSEL PROPULSION  
SYSTEMS**

**Article 11.00  
Definitions**

For the purposes of this Chapter, the following definitions shall apply

1. ~~‘propulsion installation’ a unit comprising an electrical power source including power electronics, electric propulsion motor, gearbox, shaft, propeller, etc. employed to generate movement of a craft;~~
12. ~~‘electric vessel propulsion system’ a propulsion system where the propulsor is driven by (an) electric engine(s), independent of the actual source of electric energy (on-board power network, separate power supply etc.) either a purely electric or diesel electric or gas electric propulsion installation of a craft, which is operated either by its own power supply or by the on-board network and comprising at least one electric propulsion motor. In the case of a diesel electric or gas electric propulsion installation, this term refers solely to the electrical components of the propulsion installation in question;~~
3. ~~‘electric main propulsion’ an electric vessel propulsion which is applied to achieve the manoeuvrability laid down in Chapter 5;~~
4. ~~‘electric auxiliary propulsion’ an additional electric vessel propulsion of a craft that is not an electric main propulsion;~~
25. ~~‘electric propulsion engine motor’ an electric engine driving a propulsor. motor to propel the propeller shaft or the shaft of comparable propulsion installations such as water jet propulsion devices.~~

**Article 11.01  
General provisions for electric vessel propulsion systems**

1. In addition to the applicable requirements of Chapter 8, this Chapter applies to electric propulsion systems.
2. An electric propulsion system shall consist of at least
  - a) the appropriate number of electrical power sources
    - aa) one electrical power source for an electric propulsion system with a single main propulsor;
    - bb) two electrical power sources for an electric propulsion system with more than one main propulsors,
  - b) the corresponding switchgear pursuant to Article 10.12,
  - c) an electric propulsion engine,
  - d) the respective control, monitoring and alarm equipment pursuant to Articles 7.03 and 7.04 and
  - e) depending on the design of the electric propulsion system, the corresponding power electronics.

3. A malfunction of the electric propulsion system shall not obstruct the operation of the vessel such that the emergency systems provided for in accordance with this Standard, in particular the steerage way under its own power or the emergency electrical power supply, are affected.
  4. Two electric propulsion systems can only be deemed independent if
    - a) the power supply circuits of the electric propulsion engines are completely separate from one another, or
    - b) a FMEA-S safety study demonstrates that no failure of one electric propulsion system impairs the operation of the other, or
    - c) they can be separated from each other by a separating device automatically activated in case of malfunction or failure of one of the electric propulsion systems and that can in addition be activated manually. The separating device shall provide
      - aa) downstream and upstream short circuit selectivity,
      - bb) breaking capacity for the maximum short circuit current, and
      - cc) an isolating separation between the two electric propulsion systems, enabling safe access to a powered down subsection.
  5. Each electric engine shall be provided with a manually operated and dedicated emergency shut-down device outside the wheelhouse. This requirement is deemed to be fulfilled if electric engines can be switched off at their respective switchboards. Emergency shut-down devices shall be protected against unintended activation.
  6. Electrical power sources must be designed in such a way that, taking into account the concept of the electric propulsion system, they can absorb the power feedback occurring during reversing manoeuvres.
1. ~~Craft's electric main propulsion must consist of at least~~
    - a) ~~two electrical power source, irrespective of the number of main propulsion,~~
    - b) ~~a switchgear,~~
    - c) ~~an electric propulsion motor,~~
    - d) ~~steering positions and~~
    - e) ~~depending on the design of the electric main propulsion, the corresponding power electronics.~~
  2. ~~If an electric main propulsion is equipped with only one propulsion motor and if the craft has no additional vessel propulsion that ensures sufficient propulsion power, the electric main propulsion must be designed in such a way that the craft is still capable of making steerage way under its own power while retaining the required manoeuvrability in the following cases:~~
    - a) ~~failure in the power electronics or~~
    - b) ~~failure in the regulation and control of the propulsion installation.~~
  3. ~~The general plans concerning the entire electrical installation pursuant to Article 10.01(2)(a) shall also include the locations of the main components and the electrical service rooms of the electric vessel propulsion.~~

4. If the electric propulsion motors are fed by batteries or accumulators, their capacity must be monitored and displayed.

It must be ensured that the capacity of batteries or accumulators shall enable the safe reaching of a berth under the craft's own power at all times and under all conditions.

In the event of a drop of the capacity of batteries or accumulators to the minimum residual capacity required pursuant second sentence, an optical and acoustic alarm is to be triggered and displayed in the wheelhouse.

5. If the electric vessel propulsion is gas electric or diesel electric, the electrical components must not negatively affect the gas or diesel engines.

6. A malfunction of the electric vessel propulsion shall not obstruct the operation of the craft such that the emergency systems provided for in accordance with this Standard, in particular the steerageway under its own power or the emergency electrical power supply, are affected.

7. Two electric vessel propulsions can only be deemed independent if the power supply circuits of the electric propulsion motor are completely separate from one another or if an FMEA-S safety study demonstrates that no failure of one electric propulsion impairs the operation of the other.

8. It must be possible to shut down or deactivate an electric vessel propulsion manually in an emergency.

## Article 11.02

### **Generators, transformers and switchgear for electric vessel propulsion systems**

1. The generators, transformers and switchgear must be designed for

- temporary overloads and
- the effects of manoeuvres

according to their application and operating conditions.

2. The fuel regulators of the internal combustion engines for generators of electric propulsion systems shall ensure safe operation over the entire speed range and for all sailing and manoeuvring conditions in single and parallel operation. This provision shall apply *mutatis mutandis* to fuel regulators of fuel cells. The diesel or gas regulators of diesel or gas engines for electric propulsion systems must ensure safe operation over the entire speed range and for all sailing and manoeuvring conditions in single and parallel operation.

If an electrical power source set fails according to Article 11.01(1)(a), there must be an automatic reduction in power so that the electric main propulsion continues with reduced power such that the craft is still capable of making steerageway under its own power.

3. The electrical power sources according to Article 11.01(1)(a) of the generators must be designed so that they can record the reverse power occurring during reversing manoeuvres when considering the propulsion concept.

34. ~~Generators must be capable of being switched on and off without interrupting electric main propulsion.~~ Where generators are elements of an integrated power supply, electric propulsion system shall not be interrupted when individual generators are switched on or switched off.

#### Article 11.03

##### ***Electric propulsion engines ~~motors~~ for electric vessel propulsion systems***

1. Electric propulsion engines, taking into account their application and operating conditions, must be designed in such a way that load changes, including brief overloads, and manoeuvres do not impair their safe operation.

~~According to their application and operating conditions, electric propulsion motors for electric vessel propulsion must be designed for~~

- ~~a) temporary overloads and~~
- ~~b) the effects of manoeuvres~~

2. Electric propulsion engines ~~motors~~ must be designed in such a way that harmonics of currents and voltages do not impair their safe operation.

3. The insulation of the windings must be designed for overvoltages, which can occur due to manoeuvres and switching operations. This is deemed fulfilled if the material of the windings complies with classes B, F or H in accordance with the European standard EN 60085:2008.

- ~~4. The main propulsion systems' propulsion engines, both electric and with external cooling, must be dimensioned such that, should the external cooling fail, they are still capable of operating on reduced power so that the craft is at least capable of making steerageway under its own power.~~

- ~~5. Electric propulsion motors must withstand a short-circuit at their terminals and in the propulsion installation without damage under rated operating conditions until the protective device is triggered.~~

#### Article 11.04

##### ***Power electronics for electric vessel propulsion systems***

1. The power electronics requirements according to Articles 10.18 and 10.20 shall apply with the following provisions.

2. Power electronics must be designed for the anticipated loads, including overload ~~and short circuit~~, during all operating and manoeuvring conditions.

3. If power electronics are ~~force-externally~~ cooled, they must, if their cooling system fails, be able to continue operating with reduced power so that the vessel is at least capable of making steerageway under its own power for 30 minutes. This requirement does not apply if a second independent electric propulsion system in accordance with Article 11.01(4) is present. ~~while ensuring, at a minimum, in the case of electric main propulsion, that the craft is capable of making steerageway under its own power. In the event of a failure of the cooling system, an alarm is to be triggered and displayed in the wheelhouse.~~

4. Excitation circuits, the failure of which can endanger safe operation, may only be protected against short circuits.

## Article 11.05 *Monitoring equipment*

1. ~~The operating state of the electric vessel propulsion and its principal components is to be displayed in the wheelhouse and in the propulsion installation.~~
2. ~~If the control system in the wheelhouse fails, the monitoring and operation of the electric main propulsion must be possible on-site. The crew must be able to switch within a reasonably short time without having to make changes to the propulsion installation and propeller speed and direction. A voice communication system must be provided to the wheelhouse.~~
3. The operating conditions and operation of the electric vessel propulsion system, including the response of the protective device, are to be documented in a non-volatile computer memory such that the faults can be readily analysed in a verifiable manner. This requirement does not apply to electric propulsion systems with a total power of less than 100 kW.

## Article 11.06 *Control, regulation and automatic power limitation*

1. The control and regulation equipment of the energy supply system from which an electric propulsion system is supplied shall prevent overloading of its power sources, its supply system and its consumer equipment by
  - a) timely connecting additional power sources or
  - b) disconnecting loads not required for the safe operation of the vessel, or
  - c) only in case the measures under aa) and bb) are not sufficient to equalise the power imbalance, limiting the power of the electric propulsion system for a short time. The limitation shall automatically end when the overload can no longer occur.
2. Connecting other consumer equipment and further electric propulsion engines must not lead to a power limitation of the electric propulsion systems.
1. ~~(left void)~~
2. ~~To protect the on-board network from being overloaded, provision shall also be made for~~
  - a) ~~an automatic shutdown of the electrical equipment not relating to personal safety or safe navigation and~~
  - b) ~~where required, additional automatic power limitation of the electric propulsion motors.~~
3. ~~The provisions of Article 8.03(4) apply mutatis mutandis.~~
43. In the event of individual propulsion units being shut down as a result of an automatic power limitation, the propulsion asymmetry is to be kept to a minimum.

## Article 11.07 *Protection of the electric vessel propulsion systems*

- ~~1. The automatic switching off of the electric vessel propulsion, which would affect the manoeuvrability of the craft, must be restricted to malfunctions that would result in significant damage within the propulsion installation.~~
12. Protective devices must be set so that they are ~~it is~~ not triggered in the event of situations referred to in Articles 11.02(1) and 11.03(1).
2. In the event of a malfunction or failure of the control or regulation system of the electric propulsion systems:
  - a) the propeller speed must not increase to inadmissible levels; and
  - b) the propulsion must not reverse of its own accord.
- ~~3. If a measured or reference value is lost or in the event of a power supply failure of the control or regulation system in accordance with Article 11.06:
  - a) the propeller speed must not increase to inadmissible levels;
  - b) the propulsion system must not reverse of its own accord;
  - c) no other dangerous operating condition must arise.~~
- ~~4. If an electric vessel propulsion can be mechanically locked uncontrollably, it must be equipped with a monitoring device which shall protect the electric vessel propulsion against damage.~~
35. Each electric propulsion engine ~~motor~~ is to be fitted with
  - a) earth fault monitoring;
  - b) differential protection or equivalent protective device. ~~and~~
  - ~~c) winding temperature monitoring system with an alarm trigger at high winding temperatures.~~
4. The following additional protective devices must be provided:
  - a) protection against overcurrent and short circuit;
  - b) protection against harmful bearing currents on the electric propulsion engine by means of steep voltage edges.
- ~~6. The following additional protective devices must be provided:
  - a) overspeed protection;
  - b) protection against overcurrent and short circuit;
  - c) protection against harmful bearing currents on the electric propulsion motor by means of steep voltage edges.~~
57. It must be ensured when protective devices are triggered that:
  - a) malfunctioning subsystems are selectively switched off or, where required, the power of the electric propulsion system is limited in accordance with Article 11.06; or ~~the power is reduced or malfunctioning subsystems are selectively switched off;~~
  - b) where required, the electric propulsion systems ~~s are~~ is shut down in a controlled manner; or
  - c) the power stored in components and in the load circuit cannot have a detrimental impact when they are switched off.

8. ~~The triggering of protective, reducing and alarm devices must be displayed optically and acoustically in the wheelhouse and at a suitable position of the craft. The display must be reset only after acknowledgement. An alarm condition must remain visible even after the shutdown.~~
6. To protect the electric propulsion system against undervoltage appropriate measures shall be taken to
- a) separate affected components from the rest of the electric propulsion system and
  - b) prevent components from being switched on if their power demand can cause undervoltage of the electrical power source.
- Separating devices shall provide breaking capacity for the maximum short-circuit current.

### **Article 11.08** ***Testing of the electric vessel propulsion systems***

1. The test concept envisaged by the manufacturer or the system integrator of the electric vessel propulsion system must be submitted to the inspection body before being put into service for the first time. The latter may demand additional testing and proof confirming the safe operation of the electric vessel propulsion system and its functions. This applies in particular to those instances where the craft is required to be capable of making steerageway under its own power in the event of malfunctions. ~~The test concept accepted by the inspection body is deemed to be a manufacturer's instructions according to (2).~~
2. The test concept shall cover at least:
  - a) navigation under utilisation of electric propulsion systems at full power and normal operation of all other consumer equipment on board;
  - b) navigation under utilisation of electric propulsion systems at normal operation with reduced load factor of power sources with testing of switching on and off of the different power sources;
  - c) testing of the electric propulsion systems during navigation
    - aa) in the event of failure of a power source as well as undersupply of the electric propulsion systems (worst-case scenario);
    - bb) in case of failure of external cooling of power electronics or propulsion engines;
    - cc) in case of failure of control and regulation systems of the electric propulsion systems, and
    - dd) during a stopping manoeuvre (independent of the length of the vessel);
  - d) where appropriate, testing of independence of electric propulsion systems during navigation
    - aa) in the event of failure of one element of one of the electric propulsion systems.

In addition, it has to be demonstrated that in the event of one of the failures as referred to under (c) the vessel is capable of making steerageway under its power.

The inspection body may require additional tests or documentation.

23. The electric propulsion system shall be checked by an inspection body: ~~The testing of the electric vessel propulsion must be carried out by an expert according to the manufacturer's instructions:~~
- a) before being put into service for the first time,
  - b) before being put back into service after any major modification or repair,
  - c) on every periodical inspection.

~~An inspection attestation shall be issued, signed by the expert and showing the date of the inspection. The inspection attestation must be permanently kept on board.~~

#### **Article 11.09**

#### ***Electric auxiliary propulsion with power electronics***

- ~~1. An electric auxiliary propulsion with power electronics for speed control must consist of at least a switchgear, an electric propulsion motor and the corresponding power electronics.~~
- ~~2. In addition to the provisions pursuant to Article 10.18, the power electronics of electric auxiliary propulsion shall comply with the following requirements:~~
  - ~~a) The power electronics components must be protected against exceeding their current and voltage limits.~~
  - ~~b) Semiconductor fuses must be monitored. In the event of a failure of the power electronics, the electric auxiliary propulsion is to be switched off if necessary in order to avoid consequential damage having regard to the safe operation of the craft.~~
  - ~~c) When the protective devices of power electronics are triggered, the provisions of Article 11.07(7) shall apply mutatis mutandis.~~
  - ~~d) The triggering of protective devices must be indicated by an alarm signal in the wheelhouse and on the protective devices."~~

39. Article 13.01 is amended as follows:

a) (3)(a) is worded as follows:

"a) vessels for which the stern anchor mass will be less than 150 kg; ~~in the case of vessels referred to in (1), final subparagraph, the reduced mass of the bow anchors shall be taken into account;~~".

b) (13) is worded as follows:

"13. Connecting pieces, ~~(swivels)~~ such as swivels or shackles, between anchor and chain shall withstand a tensile load 20 % higher than the breaking load of the corresponding chain.

40. Article 13.02(3)(i) is worded as follows:

"i) a searchlight that can be operated from the ~~wheelhouse~~ steering position."



41. *Article 13.05 is amended as follows:*

- a) *(2)(a) (concerns only the French version)*
- b) *(4) (concerns only the Dutch version)*
- c) *(6)(a) (concerns only the French version)*
- d) *(10)(e) (concerns only the Dutch version)*

e) (11)(f) (concerns only the French version)

f) (13)(f) (concerns only the French version)

g) (14)(c) and (d) (concerns only the Dutch version)

42. Article 15.02(10), 3<sup>rd</sup> sentence, is worded as follows:

“Sleeping cabins shall, ~~as far as possible,~~ be intended for no more than two persons.”

43. Article 15.05(1) is worded as follows:

“1. Vessels with accommodation shall have a potable water installation. The filler neck of the potable water tanks shall be fitted with a connecting piece in accordance with International Standard ISO 5620-1 : 1992 or equivalent standard recognised by one of the Member States. Potable water tank filling apertures and potable water hoses shall be marked as being intended exclusively for potable water. This requirement is deemed to be fulfilled if the requirements of the International Standard ISO 14726: 2008 are met. Potable water filler necks shall be installed above the deck.”

44. Chapter 18 is worded as follows:

**“CHAPTER 18  
ON-BOARD SEWAGE TREATMENT PLANTS**

**Article 18.00  
Definitions**

In this Chapter:

1. 'on-board sewage treatment plant': a sewage treatment plant of compact design for treating the quantities of domestic waste water accruing on board;
2. 'type-approval': the decision whereby the competent authority confirms that an on-board sewage treatment plant satisfies the technical requirements of Chapter 18;
3. 'special test': the procedure carried out in accordance with Article 18.1099 whereby the competent authority ensures that the on-board sewage treatment plant operated in a craft satisfies the requirements of Chapter 18;
4. 'manufacturer': the person or body who is responsible to the competent authority for all aspects of the type-approval procedure and for ensuring conformity of production. This person or body does not have to be involved in all stages of the construction of the on-board sewage treatment plant. If the on-board sewage treatment plant is converted by modifications or retrofitting after its original manufacture for use on a craft for the purposes of the Chapter 18, the person or body having carried out the modifications or retrofitting is considered as the manufacturer;
5. 'information document': the document set out in Annex 7, Section II that lists the information to be supplied by an applicant;
6. 'information folder': the complete set of data, drawings, photographs or other documents supplied by the applicant to the technical service or the competent authority as prescribed in the information document;
7. 'information package': the information folder plus any test reports or other documents that the technical service or the competent authority have added to the information folder in the course of their duties;
8. 'type-approval certificate': the document drawn up in accordance with Annex 7, Section III with which the competent authority certifies the type-approval;
9. 'operation management manual on-board sewage treatment plant parameters record': the manual written for the on-board sewage treatment plant in accordance with Article 18.11, document drawn up in accordance with Annex 7, Section VIII showing all the on-board sewage treatment plant's components, and containing instructions on the operation and maintenance of the on-board sewage treatment plant which records all parameters, including components of and adjustments to the on-board sewage treatment plant having an effect on the level of sewage treatment, including modifications thereto;

10. 'manufacturer's guide to checking the components and parameters relevant to sewage treatment': the document compiled in accordance with Article 18.1009(4) for the purpose of implementing the installation, performance and special tests;
11. 'domestic waste water': waste water from galleys, dining rooms, washrooms and laundries and faecal water containing faecal matter;
12. 'sewage sludge': residues accruing from operation of a sewage treatment plant on board a craft.

### **Article 18.01** **General provisions**

1. This Chapter applies to all on-board sewage treatment plants which are installed on board of craft.
2. a) On-board sewage treatment plants shall comply with the following limit values during the type test:

Table 1: Limit values to be observed in operation in the outflow of the on-board sewage treatment plant (test plant) during the type test

Parameter	Concentration (Stage II)	Sample
Biochemical oxygen demand ( $BOD_5$ ) ISO 5815-1 : 2019 and 5815-2 : 2003 <sup>1</sup>	20 mg/l	24h composite sample, homogenised
	25 mg/l	Random sample, homogenised
Chemical oxygen demand (COD) <sup>2</sup> ISO 15705 : 2022 <del>6060</del> <del>1989</del> <sup>1)</sup>	100 mg/l	24h composite sample, homogenised
	125 mg/l	Random sample, homogenised
Total organic carbon (TOC) EN 1484 : 2019 <sup>1</sup>	35 mg/l	24h composite sample, homogenised
	45 mg/l	Random sample, homogenised

- 1) Member States may implement equivalent procedures.
- 2) Instead of the chemical oxygen demand (COD) the total organic carbon (TOC) may also be referred to for the check.

- b) On-board sewage treatment plants shall comply with the following control values during operation:

Table 2: Control values to be observed in the outflow of the on-board sewage treatment plant during operation

Parameter	Concentration (Stage II)	Sample
Biochemical oxygen demand ( <i>BOD</i> <sub>5</sub> ) ISO 5815-1 : 2019 and 5815-2 : 2003 <sup>1</sup>	25 mg/l	Random sample, homogenised
Chemical oxygen demand (COD) <sup>2</sup> ISO 15705 : 2022 6060 : 1989 <sup>1</sup>	125 mg/l	Random sample, homogenised
	150 mg/l	Random sample
Total organic carbon (TOC) EN 1484 : 2019 <sup>1</sup>	45 mg/l	Random sample, homogenised

1) Member States may implement equivalent procedures.

2) Instead of the chemical oxygen demand (COD) the total organic carbon (TOC) may also be referred to for the check.

3. Processes using products containing chlorine are not admissible.

It is equally inadmissible to dilute domestic waste water so as to reduce the specific load and thereby also enable disposal

4. Adequate arrangements shall be made for storage, preservation (if necessary), and discharge of the sewage sludge. This shall also include a management plan for the sewage sludge.

5. ~~The limit values set out in Table 1 in (2)(a) shall be confirmed by a type test and determined by a type approval. The type approval shall be certified in a type approval certificate. Before installing the on board sewage treatment plant, a copy of the type approval a certificate is to be sent to the inspection body. A copy of the type approval certificate and the on board sewage treatment plant parameters record shall be carried on board.~~ For the purpose of discharging tasks pursuant to this Chapter, the competent authority may employ a technical service. The technical services responsible shall satisfy the European Standard EN 17025 : 2017, taking the following conditions into account:

- a) manufacturers of on-board sewage treatment plants cannot be recognised as technical services;
- b) for the purposes of this Chapter a technical service may, with the agreement of the competent authority, make use of facilities external to its own laboratory.

6. Each on-board sewage treatment plant shall come with an operation management manual in compliance with Article 18.11. The operation management manual shall be carried on board. ~~After the on-board sewage treatment plant has been installed on board a performance test shall be carried out by the manufacturer before scheduled service begins. The on-board sewage treatment plant shall be entered in item 52 of the inland navigation vessel certificate with the following plant particulars:~~
  - ~~a) name;~~
  - ~~b) type approval number;~~
  - ~~c) serial number;~~
  - ~~d) year of construction.~~
7. The limit values set out in Table 1 in (2)(a) shall be confirmed by a type test and determined by a type-approval. The type-approval shall be certified in a type-approval certificate. The operation management manual and a copy of the type-approval certificate shall be submitted to the competent authority and the technical service upon request. ~~Any significant modification to an on-board sewage treatment plant that has an effect on the sewage treatment shall always be followed by a special test in accordance with Article 18.09(3).~~
8. The on-board sewage treatment plant shall be designed in such a way that operating faults or the failure of the on-board sewage treatment plant do not result in untreated sewage being discharged into the waterway. ~~For the purpose of discharging tasks pursuant to this Chapter, the competent authority may employ a technical service.~~
9. Each on-board sewage treatment plant shall have a sampling point (sampling tap). ~~The on-board sewage treatment plant shall be regularly maintained in accordance with the manufacturer's instructions in order to ensure that it is in perfect working order. A maintenance log corroborating such maintenance shall be carried on board.~~
10. The following data shall be entered in item 52 of the inland navigation vessel certificate for all on-board sewage treatment plants:
  - a) name of the manufacturer;
  - b) on-board sewage treatment plant type;
  - c) type-approval number;
  - d) serial number;
  - e) year of construction.
11. The on-board sewage treatment plant shall be serviced at regular intervals and in accordance with the manufacturer's instructions. Maintenance shall be documented in the operation management manual.

**Article 18.02**  
***Application for type-approval***

1. An application for type-approval for an on-board sewage treatment plant type shall be submitted by the manufacturer to the competent authority. The application shall enclose
  - a) An information folder in accordance with Article 18.00(6),
  - b) and the draft of ~~an on-board sewage treatment plant parameters record~~ the operation management manual in accordance with Article 18.1100(9), and
  - c) ~~as well as the draft of a~~ manufacturer's guide to checking the components and parameters relevant to sewage treatment for that on-board sewage treatment plant type in accordance with Article 18.00(10) ~~shall be enclosed with the application.~~

For the type test the manufacturer shall demonstrate a prototype of the on-board sewage treatment plant.

2. If, in a particular application for type-approval for an on-board sewage treatment plant type, the competent authority finds that the application submitted with regard to the presented plant prototype is not representative of the characteristics of this type of on-board sewage treatment plant as described in Annex 7, Section II, Appendix 1 another, if necessary additional, prototype, to be designated by the competent authority, shall be supplied for approval in accordance with (1).
3. No application for type-approval for an on-board sewage treatment plant type may be submitted to more than one competent authority. A separate application shall be submitted for each on-board sewage treatment plant type to be approved.

**Article 18.03**  
***Type-approval procedure***

1. The competent authority to which the application is submitted shall issue the type-approval for the on-board sewage treatment plant type which corresponds to the descriptions in the information folder and satisfies the requirements of this Chapter. The fulfilling of these requirements will be ~~proven by a type test~~ ~~examined~~ in accordance with Annex 7, Section IX.
2. For each on-board sewage treatment plant type that it type-approves, the competent authority shall complete all relevant parts of the type-approval certificate, the model for which is to be found in Annex 7, Section III, and shall compile or verify the contents of the index to the information package. Type-approval certificates shall be numbered in accordance with the method described in Annex 7, Section IV. The completed type-approval certificate and its Annexes shall be delivered to the applicant.
3. If the on-board sewage treatment plant to be approved can only fulfil its function or only has specific properties in conjunction with other components of the craft in which it is to be installed and if for this reason compliance with one or more requirements can only be checked if the on-board sewage treatment plant to be approved is operated together with other real or simulated components of the craft, the scope of the type-approval for this on-board sewage treatment plant shall be limited accordingly. In such cases, all restrictions on use and all installation requirements shall be detailed in the type-approval certificate for that plant type.

**Article 18.04**  
***Amendment of type-approvals***

1. The competent authority which issued the type-approval shall make the necessary arrangements to ensure that it is informed of any change in the particulars appearing in the information package.
2. The application for amendment or extension of a type-approval shall be made exclusively to the competent authority which issued the original type-approval.
3. Should characteristics of the on-board sewage treatment plant as described in the information package have been modified, the competent authority shall:
  - a) issue revised pages of the information package as necessary, marking each revised page to show clearly the nature of the change and the date of re-issue. Whenever revised pages are issued, the index to the information package which is attached to the type-approval certificate shall also be updated accordingly;
  - b) issue a revised type-approval certificate (with an extension number) if any information on it (excluding its annexes) has changed or if the minimum requirements of this Chapter have changed since the original approval date. The revised type-approval certificate shall clearly show the reason for its modification and the date of the re-issue

Should the competent authority which issued the type-approval find that new trials or tests are justified owing to a modification made to the information package, it shall notify the manufacturer of this fact and issue the documents specified above only after new trials or tests have been successfully completed.

**Article 18.05**  
***Conformity of the type-approval***

1. The manufacturer shall affix to each on-board sewage treatment plant manufactured in conformity with the type-approval the markings as defined in Annex 7, Section I, including the type-approval number.
2. Should the type-approval contain limitations of usage in accordance with Article 18.03(3), the manufacturer shall enclose detailed information on these limitations and all installation requirements with each unit manufactured.
3. If requested by the competent authority which issued the type-approval, the manufacturer shall provide a list of the serial numbers of all on-board sewage treatment plants which have been manufactured in accordance with the requirements set out in this Chapter since the last report, or since the point at which these provisions first came into force, within 45 days after the end of each calendar year, and immediately after each additional date specified by the competent authority. The list shall set out the correlations between the serial numbers, the corresponding on-board sewage treatment plant types and the type-approval numbers. Furthermore, the list shall also include particular information for those cases where the manufacturer discontinues production of a type-approved on-board sewage treatment plant type. Should the competent authority not demand the regular provision of such a list from the manufacturer, the manufacturer shall retain the data recorded for a period of at least 40 years.



**Article 18.06**  
***Checking of serial numbers***

1. The competent authority issuing a type-approval shall ensure that the serial numbers of the on-board sewage treatment plants manufactured in conformity with the requirements of this Chapter are registered and checked. It may collaborate with other authorities as defined in this Chapter and with the competent authorities of the Member States.
2. An additional check of the serial numbers may take place in conjunction with the check on conformity of production with requirements laid down in Article 18.07.
3. In relation to the checking of the serial numbers, the manufacturer or their authorised representatives located in the Member States shall, if requested, promptly supply the competent authority with all necessary information relating to their direct purchasers as well as the serial numbers of those on-board sewage treatment plants which have been reported as manufactured in accordance with Article 18.05(3).
4. Should a manufacturer be unable to comply with the requirements set out in Article 18.05 when requested to do so by the competent authority, the approval for the on-board sewage treatment plant type concerned may be withdrawn. In such a case the notification procedure specified in Article 18.08(4) shall be used.

**Article 18.07**  
***Conformity of production***

1. The competent authority issuing a type-approval shall ascertain in advance that suitable arrangements have been made to ensure effective checking of conformity of production in respect of the requirements of Annex 7, Section I. It may collaborate with other authorities as defined in this Chapter and with the competent authorities of the Member States.
2. The competent authority which has issued a type-approval shall ascertain that the arrangements specified in (1) in respect of the provisions of Annex 7, Section I continue to be sufficient and that every on-board sewage treatment plant provided with a type-approval number in accordance with the requirements of this Chapter continues to correspond to the description in the type-approval certificate and its annexes for the type-approved on-board sewage treatment plant type. It may collaborate with other authorities as defined in this Chapter and with the competent authorities of the Member States.
3. The competent authority may recognise comparable tests carried out by other competent authorities as equivalent to the provisions of (1) and (2).

### **Article 18.08**

#### ***Non-conformity with the type-approved on-board sewage treatment plant type***

1. Non-conformity with the type-approved on-board sewage treatment plant type shall be deemed to exist when there are deviations from the characteristics in the type-approval certificate or, as the case may be, from the information package which have not been approved in accordance with Article 18.04(3) by the competent authority which issued the type-approval.
2. Should the competent authority which has issued a type-approval find that on-board sewage treatment plants do not conform with the on-board sewage treatment plant type for which it issued the approval, it shall take the necessary measures to ensure that on-board sewage treatment plants in production again conform with the type-approved on-board sewage treatment plant type. The competent authority which found the non-conformity shall inform the other competent authorities of the measures taken, which may extend to withdrawal of the type-approval.
3. If a competent authority is able to demonstrate that on-board sewage treatment plants provided with a type-approval number do not conform with the type-approved on-board sewage treatment plant type, it may require the competent authority which issued the type-approval to have the on-board sewage treatment plant type that is in production checked for conformity with the type-approved on-board sewage treatment plant type. Such action shall be taken within six months of the date of the request.

### **Article 18.09**

#### ***Installation and performance test***~~***Random sample measurement / Special test***~~

1. After the sewage treatment plant has been installed on board an installation and performance test shall be carried out before regular operation begins.
2. The installation and performance test shall include:
  - a) Checking whether all the intended components or component groups have been correctly installed in accordance with the type-approval certificate and with the manufacturer's guide to checking the components and parameters of the on-board treatment plant relevant to sewage treatment;
  - b) Checking the proper functioning of the sewage treatment plant aboard the vessel.
3. The performance test as per 2(b) shall also be conducted if the on-board treatment plant is temporarily taken out of operation or undergoes maintenance.
4. Each installation and performance test shall be certified by the competent authority in the operation management manual in the form of the model in Annex 7 section VIII. The performance test specified in (3) can be certified by a specialised firm.

## Article 18.10

### ~~Competent authorities and technical services~~ Random sample measurement / Special test

~~The technical services responsible shall satisfy the European Standard EN 17025 : 2017, taking the following conditions into account:~~

- ~~a) manufacturers of on-board sewage treatment plants cannot be recognised as technical services;~~
- ~~b) for the purposes of this Chapter a technical service may, with the agreement of the competent authority, make use of facilities external to its own laboratory.~~

1. No later than three months after the commissioning of the craft or, in the case of retrofitting of the on-board sewage treatment plant, after it has been installed and the appropriate installation and performance test has been carried out, the competent authority shall take a random sample during operation of the craft in order to check the values set out in Article 18.01(2), Table 2.

At irregular intervals the competent authority shall carry out functionality checks on the on-board sewage treatment plant by means of random sample measurements to check the values set out in Article 18.01(2), Table 2.

Should the competent authority find that the values of the random sample measurements do not conform with the values set out in Article 18.01(1), Table 2, it may demand:

- a) that the defects in the on-board sewage treatment plant be remedied so as to ensure that it runs properly;
- b) that the on-board sewage treatment plant be made to conform with the type-approval again; or
- c) that a special test be carried out in accordance with (3).

Once the non-conformities have been remedied and the on-board sewage treatment plant has been made to conform with the type-approval again, the competent authority may carry out new random sample measurements.

If the defects are not remedied or the conformity of the on-board sewage treatment plant with the specifications of the type-approval is not restored, the competent authority shall seal the on-board sewage treatment plant and inform the inspection body to make an entry to that effect in item 52 of the inland navigation vessel certificate.

2. The random samples shall be measured in accordance with the specifications of Article 18.01(2), Table 2.
3. Should the competent authority find any discrepancies in the on-board sewage treatment plant indicating a deviation from the type-approval, the competent authority shall carry out a special test to determine the present state of the on-board sewage treatment plant in relation to the components specified in the on-board sewage treatment plant parameters record, the calibration and the setting of the parameters of the on-board sewage treatment plant.

Should the competent authority come to the conclusion that the on-board sewage treatment plant is not in conformity with the type-approved on-board sewage treatment plant type, it may take the following actions:

- a) demand that
  - aa) the conformity of the on-board sewage treatment plant be restored; or
  - bb) the type-approval in accordance with Article 18.04 be amended accordingly; or
- b) order measurement in accordance with the test procedure as set out in Annex 7, Section IX.

If conformity is not restored or the type-approval is not amended accordingly, or if it becomes apparent from the measurements made in accordance with (b) that the limit values laid down in Article 18.01(2)(a), Table 1 are not complied with, the competent authority shall seal the on-board sewage treatment plant and inform the inspection body to make an entry to that effect in item 52 of the inland navigation vessel certificate.

4. The tests in accordance with (3) shall be carried out on the basis of the type-approval certificate and the manufacturer's guide to checking the components and parameters of the on-board sewage treatment plant relevant to sewage treatment. This guide, which shall be compiled by the manufacturer and approved by a competent authority, shall specify the treatment-relevant components as well as settings, dimensioning criteria and parameters to be applied in order to ensure that the values set out in Article 18.01(2), Tables 1 and 2 are continuously maintained. It shall include at least the following information:
  - a) a specification of the on-board sewage treatment plant type with a process description and an indication of whether waste-water storage tanks are to be installed upstream of the on-board sewage treatment plant;
  - b) a list of the components specific to sewage treatment;
  - ~~c) the design and dimensioning criteria, dimensioning specifications and regulations applied.~~
  - ca) a schematic representation of the on-board sewage treatment plant with identifying features of the approved treatment-relevant components (e.g. part numbers on the components).
5. An on-board sewage treatment plant that has been sealed in accordance with (3) 3rd sentence may be brought back into service only after a special test in accordance with (3), first subparagraph.

#### **Article 18.11**

##### ***Operation management manual and instructions***

1. Each on-board sewage treatment plant shall have an operation management manual. The operation management manual shall be produced by the manufacturer of the sewage treatment plant installed on-board.
2. The operation management manual shall contain:
  - a) On-board sewage treatment plant components relevant to its operation according to Article 18.10(4),
  - b) Operating instructions:
    - aa) for both manual and automated operation of the on-board sewage treatment plant,
    - bb) for standby operation of the on-board sewage treatment plants,
    - cc) for emergency operation of the on-board sewage treatment plant,
    - dd) on the run-down, standstill and restart operation of the on-board sewage treatment plant,
    - ee) for the special treatment of greasy wastewater and galley waste water,
    - ff) for ongoing inspection and regular maintenance activities during operation as well as fuel supply,
    - gg) for sludge management (determining the sludge content, altering the sludge content),
  - c) Instructions and proofs regarding maintenance and repair,
  - d) Documentation templates,
    - aa) for documenting ongoing and regular inspection and maintenance activities and
    - bb) for documenting excess quantities of sludge and the depositing thereof."

45. Article 19.02 is amended as follows worded as follows:

a) (1a) is worded as follows:

“1a. Where materials other than steel, such as aluminium alloy or Fibre Reinforced Plastic composites, are being used for the construction of a passenger vessel, these materials structural components, such as bulkheads, walls, decks, ceilings and pillars, shall maintain load-carrying capabilities

~~a) comply with the requirements of Article 3.02(2) and~~

~~b) have structural and integrity properties equivalent to steel, at the end of the applicable fire exposure according to the standard one-hour fire test.~~

a) in spaces of major or high fire risk, up to the end of a standard one hour fire test,

b) in spaces of moderate fire risk, up to the end of a standard half-hour fire test, and

c) of supporting structure of rooms or areas protected for functional need, up to the end of a standard half-hour fire test.

In addition, the material of structural components shall be non-combustible or fire-restricting.

The requirements relating to load-carrying capabilities of the structural components ~~Compliance for the construction material~~ shall be deemed to be fulfilled if a certificate, either for the structural components or for the insulation protecting these components, is established ~~by an accredited test institution,~~ in accordance with Article 19.11(1)(a), ~~and (d) and (e), and may take into account the insulation provided.”~~

b) (10)(d) (concerns only the French version)

46. Article 19.06 is amended as follows:

a) (8)(f) is worded as follows:

“f) Life-saving appliances shall be easily accessible from the muster or evacuation areas. In principle, the ~~live~~ life-saving appliances shall be stored nearby or within the muster or evacuation areas.”

b) (9), last sentence (concerns only the Dutch version)

c) (12)(d) (concerns only the French version)

d) (15) (concerns only the French version)

47. Article 19.08(2) is worded as follows:

“2. All passenger areas shall be reachable via a loudspeaker system. The system shall be designed in such a way as to ensure that the information transmitted can be clearly distinguished from background noise. Loudspeakers are optional where direct communication between the ~~wheelhouse~~ steering position and the passenger area is possible.”

48. *Article 19.10 is amended as follows:*

- a) *(4)(b) (concerns only the French version)*
- b) *(6) (concerns only the French version)*

49. Article 19.11 is amended as follows:

a) (1) and (2) are worded as follows:

- "1. The suitability for fire protection of materials and components shall be established by an accredited test institution on the basis of appropriate test methods.
- a) The test institution shall satisfy:
    - aa) the Code for Fire Test Procedures; or
    - bb) European Standard EN 17025 : 2017.
  - b) The recognised test methods for determining the non-flammability of materials are:
    - aa) Annex 1, Part 1, of the Code for Fire Test Procedures; and
    - bb) the equivalent regulations of one of the Member States.
  - c) The recognised test methods for determining that a material is flame-retardant are:
    - aa) the respective requirements laid down in Annex 1, Parts 5 (Test for surface flammability - Test for surface materials and primary deck coverings), 7 (Test for vertically supported textiles and films), 8 (Test for upholstered furniture) and 9 (Test for bedding components) of the Code for Fire Test Procedures; and
    - bb) the equivalent regulations of one of the Member States.
  - d) The recognised test methods for determining fire resistance are:
    - aa) Annex 1, Parts 3 and 11, of the Code for Fire Test Procedures, and
    - bb) the equivalent regulations of one of the Member States.
  - e) The recognised test methods for determining that a material is fire-restricting are:
    - aa) Annex 1, Part 10, of the Code for Fire Test Procedures; and
    - bb) the equivalent regulations of one of the Member States.
  - fe) The inspection body may, in accordance with the Code for Fire Test Procedures, prescribe a test on a sample partition in order to ensure compliance with the provisions of (2) on resistivity and temperature increase.

## 2. Partitions

For determining the appropriate fire partition to be applied to boundaries between adjacent rooms or areas, such rooms or areas are classified according to their fire risk as shown in categories below. A non-exhaustive list of rooms or areas is given for each category. In case a new type of room or area is foreseen, it may be placed in the relevant fire risk category as found appropriate by the Inspection body. Where contents and use of a room or area leave a doubt regarding its classification for the purpose of this regulation, or where it is possible to assign two or more classifications to a room or area, it shall be treated as a room or area within the relevant category having the most stringent partition requirements.

a) **Partitions** between rooms / **areas** shall be designed in accordance with the following tables:

aa) Table for partitions between rooms or areas, in which no pressurised water sprinkler systems according to Article 13.04 are installed

Rooms / areas	Rooms / areas protected for functional need	Rooms of major fire risk	Rooms of high fire risk	Rooms of moderate fire risk	Rooms of low fire risk
Rooms / areas included in the category	Control centres Switchboard rooms Stairwells Muster areas Evacuation areas Rooms containing sprinkler pumps, their switches and the valves that are required in order for the system to be operated	Engine rooms Accumulator rooms	Galleys Stores rooms containing flammable liquids	Store rooms Rooms containing Sauna Laundries Electrical service rooms Rooms containing sprinkler pumps, their switches and the valves that are required in order for the system to be operated	Lounges Barber shops and beauty parlours Cabins Corridors Other machinery / technical spaces (e.g. sewage treatment, ventilation, steering gear room)
Rooms / areas protected for functional need	A0 / B0 <sup>1), 7), 9)</sup>	A60	A60	A30	A30 / B15 <sup>2), 9)</sup>
Rooms of major fire risk		A60 / A0 <sup>4)</sup>	A60	A60	A60
Rooms of high fire risk			A30 <sup>7)</sup>	A30 / B15 <sup>6)</sup>	A30
Rooms of moderate fire risk				A30 <sup>3) 7)</sup>	A30 <sup>3)</sup>
Rooms of low fire risk					B15 <sup>8)</sup>



bb) Table for partitions between rooms or areas, in which pressurised water sprinkler systems according to Article 13.04 are installed (a pressured water sprinkler system is installed in the rooms on both sides of the partition).

Rooms / areas	Rooms / areas protected for functional need	Rooms of major fire risk	Rooms of high fire risk	Rooms of moderate fire risk	Rooms of low fire risk
Rooms / areas included in the category	Control centres Switchboard rooms Stairwells Muster areas Evacuation areas Rooms containing sprinkler pumps, their switches and the valves that are required in order for the system to be operated	Engine room Accumulator room	Galley Store rooms containing flammable liquids	Store rooms Rooms containing Sauna Laundry Electrical service rooms Rooms containing sprinkler pumps, their switches and the valves that are required in order for the system to be operated	Lounges Barber shops and beauty parlours Cabins Corridors Other machinery / technical spaces (e.g. sewage treatment, ventilation, steering gear room)
Rooms / areas protected for functional need	A0 / B0 <sup>1), 7), 9)</sup>	A60	A30	A0 / A30 <sup>5), 9)</sup>	A0 / A30 / B15 <sup>2), 9)</sup>
Rooms of major fire risk		A60 / A0 <sup>4)</sup>	A60	A60	A60
Rooms of high fire risk			A30 <sup>7)</sup>	A30 / B15 <sup>6)</sup>	A30
Rooms of moderate fire risk				A0 <sup>7)</sup>	A0
Rooms of low fire risk					B0 <sup>8)</sup>

- 1) Partitions between control centres and external muster areas shall correspond only to Type B0.
- 2) For rooms which are not protected by a spinkler system; partitions between rooms of low fire risk and external muster areas shall correspond to Type B15. In all other cases they shall comply with Type A30.  
For rooms which are protected by a pressured water sprinkler system; partitions between rooms of low fire risk and internal muster areas shall correspond to Type A30, but external muster areas only to Type B15. In all other cases they shall comply with Type A0.
- 3) Partitions between rooms of accommodation or passenger rooms shall correspond only to Type A0.
- 4) Partitions between engine rooms shall comply with Type A0, except for rooms according to Articles 19.07 and 19.10(6), which shall comply with A60. In all other cases they shall comply with Type A60.
- 5) Partitions between rooms of moderate fire risk and muster areas shall correspond to Type A30.

- 6) No partition is required between galleys and adjacent food store rooms provided that outer perimeter of galleys including stores fulfills the requirements for galleys.
- 7) Where adjacent rooms have the same purpose, the partitions need not to comply with the requirements of this table (for example; the partition between two stores).
- 8) Where adjacent technical spaces have the same purpose, the partitions made of material other than steel need not to comply with the requirements of this table, however, a smoke-tight division of non-combustible or fire restricting material is required.
- 9) Partitions between rooms containing pumps, switching mechanisms and valves of fire-fighting systems referred to in Article 13.05(14)(c) and adjacent rooms shall correspond at least to Type A30.

- cc) For partitions made of material other than steel, type A and type B partitions can be replaced by partitions providing following characteristics:

Type A / Type B partition	Transmission of smoke and flames in minutes	Insulation value in minutes (according to Article 19.11(2)(d)(cc))
B0	30	0
B15	30	15
A0	60	0
A30	60	30
A60	60	60

The suitability of the fire protection of those partitions shall be established according to Article 19.11(1)(d), with the fire on the side of the rooms and areas of major fire risk, high fire risk and moderate fire risk.

- b) Type A partitions are bulkheads, walls and decks which meet the following requirements:
- aa) They are made of steel or of another equivalent material;
  - bb) They are appropriately stiffened;
  - cc) They are insulated with an approved non-combustible material such that the average temperature on the side facing away from the fire rises to not more than 140 °C above the initial temperature and at no point, including the gaps at the joints, does a temperature increase of more than 180 °C above the initial temperature occur within the following specified periods:
    - Type A60 60 minutes
    - Type A30 30 minutes
    - Type A0 0 minutes;
  - dd) they are constructed in such a way as to prevent the transmission of smoke and flames until the end of the one-hour standard fire test;
- c) Type B partitions are bulkheads, walls, decks, ceilings or facings which meet the following requirements:
- aa) they are made of an approved non-combustible material. Furthermore, all materials used in the manufacture and assembly of partitions shall be non-combustible, except for the facing, which shall be at least flame retardant;
  - bb) they demonstrate an insulation value such that the average temperature on the side facing away from the fire rises to not more than 140 °C above the initial temperature and at no point, including the gaps at the joints, does a temperature increase of more than 225 °C above the initial temperature occur within the following specified periods:
    - Type B15 15 minutes
    - Type B0 0 minutes;
  - cc) they are constructed in such a way as to prevent the transmission of flames until the end of the first half hour of the standard fire test.

- d) Partitions made of fire-restricting materials are bulkheads, walls, decks, ceilings of facings which meet the following requirements:
  - aa) they are constructed in fire-restricting material and are suitably stiffened;
  - bb) they are constructed in such a way as to prevent the transmission of flames and smokes according to Article 19.11(2)(b)(dd) and (c)(cc) as applicable;
  - cc) they demonstrate an insulation according to Article 19.11(2)(b)(cc) and (c)(bb) as applicable;
  - dd) partitions which are part of the load carrying construction shall also comply with Article 19.02(1a);
  - ee) the insulation is to be placed on each side of the partitions in accordance with the fire risk of that room;
  - ff) the upper side of deck within rooms protected by a water-based fixed firefighting installation need not to be insulated.”

b) (19) hereafter is added after (18):

“19. All rooms made of combustible materials, such as Fibre Reinforced Plastic composites, which are not engine rooms, empty cells or tanks forming part of the ship's hull, shall be equipped with a permanently installed firefighting system according to Article 13.04 or Article 13.05 depending on the type of rooms.”

50. Article 19.13(2), last sentence, is worded as follows:

“The symbols used in the safety plan shall be in accordance with the international standard ISO 17631 : ~~2002~~ 2022 or other recognized standards.”

51. In Article 19.15, a new (13) is added after (12):

“13. For day-trip vessels operating limited journeys of local interest or in harbour areas, the inspection body may authorise a shorter time than the 30 minutes required in Article 7.04(11). The journeys or areas for which such derogation is valid shall be specified in the inland navigation vessel certificate.”

52. *Article 25.01(2)(c) and (d) are worded as follows:*

"c) to Chapter 7:

Article 7.01(2), Article 7.02(1) and (3), 1<sup>st</sup> and 2<sup>nd</sup> subparagraphs, Article 7.04(11)(e), Article 7.05(2),

Article 7.13 for sea-going vessels designed for radar navigation by one person;

d) to Chapter 8

Article 8.03(32) for sea-going vessels when an automatic shut-off device can be switched off from the steering position; Article 8.05(13), Article 8.08(10), Article 8.09(1) and (2) and Article 8.10.

Locking the closures in position prescribed in Article 8.08(10) shall be regarded as equivalent to sealing the closures of the bilge system through which the oily water can be pumped out of the vessel. The required key or keys must be kept in a central location which shall be marked accordingly.

An oil discharge monitoring and control system complying with Regulation 16 of MARPOL 73/78 shall be deemed equivalent to locking the closures in position prescribed in Article 8.08(10). The existence of the monitoring and control system must be attested by an international oil pollution prevention (IOPP) certificate that complies with MARPOL 73/78.

If the IOPP attestation reveals that the vessel is equipped with collecting tanks enabling all the oily water and oily residues to be retained on board, Article 8.09(2) must be deemed to have been complied with;".

53. *Article 26.01 is amended as follows:*

a) *(1)(d) and (e) are worded as follows:*

"d) from Chapter 7:

Article 7.01(1) and (2), Article 7.02, Article 7.03(1) and (2), Article 7.04(1), Article 7.04(11)(e), Article 7.05(2),

Article 7.06(3) in case of recreational craft for which the applicable navigational authority regulations for certain areas of navigation in the Member States specify that they must be equipped with Inland AIS equipment,

Article 7.13;

e) from Chapter 8:

Article 8.01(1) and (2), Article 8.02(1) and (2), Article 8.03(1) and (32), Article 8.04, Article 8.05(1) to (5),

Article 8.05(6) or as an alternative with the technical requirements of Standard EN ISO 10088 : 2017 2023,

Article 8.05(7) to (10) and (13), Article 8.06, Article 8.07, Article 8.08(1), (2), (5), (7) and (10), Article 8.09(1), and Article 8.10;".

b) (2)(c) and (d) are worded as follows:

“c) from Chapter 8:

Article 8.01(2), Article 8.02(1), Article 8.03(32), Article 8.05(5), and Article 8.08(2);

d) from Chapter 13:

Article 13.01(2), (3), (6) and (14), Article 13.02(1)(b) and (c), (3)(a) and (e) to (h), Article 13.03(1)(b) and (d),

Article 13.03 (2) to (6) as an alternative with the technical requirements of Standard ISO 9094 : 2022~~2015~~, and

Article 13.08, however

aa) non-inflatable lifejackets are also admissible for adults;

bb) the requirement for three lifebuoys under Article 13.08(1) may be reduced to two;

cc) horseshoe lifebuoys are permitted;”.

54. *Article 27.02, title (concerns only the French version)*

55. *Article 28.03(4)(c) (concerns only the French version)*

56. *Article 29.08(2)(a) (concerns only the French version)*

57. Chapter 30 is worded as follows:

**“CHAPTER 30  
SPECIAL PROVISIONS APPLICABLE TO CRAFT EQUIPPED WITH  
PROPULSION OR AUXILIARY SYSTEMS OPERATING ON FUELS WITH A  
FLASHPOINT EQUAL TO OR LOWER THAN 55 °C**

**Article 30.00  
Definition**

For the purposes of this Chapter, the following definition shall apply:

“propulsion and auxiliary system”: any system using fuel, including fuel tanks, tank connections, fuel preparation systems, piping, valves, energy converters (such as engines, turbines or fuel cells), control, monitoring and safety systems.

**Article 30.01  
Scope of application**

1. This chapter applies to craft with propulsion or auxiliary systems operating on fuels with a flashpoint equal to or lower than 55 °C.
2. In addition to the requirements of this chapter, Annex 8 applies, providing requirements that are specific for the storage and energy converters for the different fuels. ~~provides for those requirements that are specific for certain fuels.~~
3. The provisions of this Chapter shall not apply to fuel cells components, which are part of auxiliary systems operating on fuels with a flashpoint equal to or lower than 55 °C ~~according to (1)~~ and with a cumulative reference power that is less than 20 kW.

**Article 30.02  
General**

1. Craft according to Article 30.01(1) must comply with the mitigation measures identified by the risk assessment according to Article 30.04.
2. Unless otherwise specified in Annex 8 and if necessary, derogations to Articles 8.01(3) and 8.05(1), (6), (9), (11), (12) are permitted provided that the craft meets an equivalent level of safety.

If the energy converter of the craft generates gaseous or particulate pollutants but does not fall in the scope of application of Chapter 9, the emissions of gaseous and particulate pollutants from the energy converter shall be equivalent or lower than those of the internal combustion engines referred to in Article 9.01(2). The inspection body may ask for a report which demonstrates its compliance to this requirement.

**Article 30.03**  
***Tasks of the inspection body and technical service, documentation***

1. Propulsion and auxiliary systems of craft according to Article 30.01(1) shall be constructed and installed under the supervision of the inspection body.
2. For the purpose of discharging tasks pursuant to this chapter, the inspection body may employ a technical service. The technical services shall satisfy the European Standard EN ISO 17020 : 2012. The knowledge of the technical service shall cover at least the following areas:
  - a) fuel system including tanks, heat exchangers, pipelines,
  - b) strength (longitudinal and local) and stability of the craft,
  - c) electrical installation and control, monitoring and safety systems,
  - d) ventilation system,
  - e) fire safety, and
  - f) gas warning equipment.

Manufacturers and distributors of propulsion or auxiliary systems, or parts of these systems, cannot be recognised as technical services.

The supervision and testing according to Articles 30.03(1) and 30.11 may be performed by different technical services provided that all the expertise described above is taken into account in the process.

3. Before commissioning of a propulsion or auxiliary system according to Article 30.01(1), the following documents shall be submitted to the inspection body:
  - a) a risk assessment according to Article 30.04,
  - b) a description of the propulsion or auxiliary system,
  - c) drawings of the propulsion or auxiliary system,
  - d) a diagram of the pressure and temperature within the system,
  - e) the operating manual according to 30.05(5), and
  - f) a safety rota according to Article 30.05(1), and
  - ~~g) a copy of the inspection certificate referred to in Article 30.11(4).~~
4. The technical documentation according to (3) shall enable an assessment of whether craft, propulsion and auxiliary systems and their components comply with the applicable rules, regulations, standards applied and principles regarding safety, availability, maintainability and reliability.
5. A copy of the documents according to (3) shall be kept on board.



## Article 30.04 Risk assessment

1. A risk assessment shall be conducted to ensure that risks arising from the use of fuels with a flashpoint equal to or lower than 55 °C affecting people on board including passengers, the environment, the structural strength and the integrity of the craft, are addressed.
2. The risk assessment shall include at least:
  - a) a hazard identification (HAZID) which combines techniques, as described in ISO 31010 : 2019, to identify risks, assess the risks and provide ~~find, list and characterize hazards as well as to identify~~ measures to eliminate or mitigate these ~~hazards~~ risks. In selecting the appropriate techniques, the nature and scale of the propulsion or auxiliary system in the craft, as well as the experience of similar systems is to be considered.
  - b) the classification of hazardous areas on board, divided into zones 0, 1 and 2, according to Article 1.01(3.23).

In the light of the outcome of the hazard identification (HAZID), the inspection body may request additional risk analysis (e.g. quantitative risk analysis, failure modes, effects and (criticality) analysis (FME(C)A), hazard and operability study (HAZOP) or fire and explosion risk analysis).

3. As a minimum, the process of the hazard identification (HAZID) shall consider the following risks:
  - a) hazards associated with physical layout,
  - b) the mechanical damage to components,
  - c) influences related to operations, bunkering, purging, maintenance, cargo-related and weather-related influences,
  - d) electrical failures,
  - e) unintended chemical reactions,
  - f) release of toxic vapours,
  - g) self-ignition of fuels,
  - h) fire,
  - i) explosion,
  - j) temporary power outage (blackout),
  - k) flooding of water in parts of the craft which may contain fuel or hazardous vapours,
  - l) craft sinking.
4. As a minimum, the process of the hazard identification (HAZID) shall involve:
  - a) a risk assessment facilitator,
  - b) fuel related safety experts,
  - c) craft and system designers,
  - d) the shipyard or equivalent entity having an overview of the shipbuilding,
  - e) the equipment suppliers,
  - f) the future craft operator,
  - g) a boatmaster.

The inspection body must be permitted to attend as observer the risk assessment process.

5. The risk assessment shall ensure that risks are eliminated wherever possible. Risks which cannot be eliminated entirely are to be mitigated to an acceptable level in accordance with (6). Details of risks, and the measures by which they are mitigated, shall be documented to the satisfaction of the inspection body.
6. Craft according to Article 30.01(1) must fulfil the following requirements:
  - a) A single failure in parts of the craft which may contain fuel or hazardous vapours, such as engines, fuel tanks and associated piping, shall not lead to an unsafe situation.
  - b) The level of safety, reliability and dependability of the craft shall be at least equivalent to that of craft with main and auxiliary machinery using fuels having a flashpoint of more than 55 °C.
  - c) The probability and consequences of fuel-related hazards shall be minimised through system design. Failure of risk-reducing measures shall lead to measures mitigating the impact on safety.
  - d) Fuel supply, storage and bunkering arrangements shall be suitable to receive and contain fuel in the required state without leakage or venting under normal operating conditions.
  - e) A fire or explosion in parts of the craft which may contain fuel or hazardous vapours shall not:
    - aa) damage or disrupt the proper functioning of equipment/systems located in any space other than that in which the incident occurs;
    - bb) damage the craft in such a way that flooding of water below the main deck or any progressive flooding occurs;
    - cc) damage work areas or accommodation in such a way that persons who stay in such areas under normal operating conditions are injured or exposed to hot temperatures or toxic substances;
    - dd) injure persons as well as prevent persons' access to life-saving appliances or impede escape routes either by physical blockage, heat or toxic substances.
7. In agreement with the inspection body, the scope of the risk assessment can exclude concepts in whole or in part that have been previously subjected to a risk assessment, provided that:
  - a) there are no changes to the arrangements or design, location of the installation, mode of operation, type of fuels, use of surrounding spaces or to the number of persons exposed, and
  - b) mitigation measures taken as a result of previous risk assessments are included.

**Article 30.05**  
**Safety organisation**

1. A safety rota shall be provided on board craft according to Article 30.01. The safety rota shall include safety instructions according to (2) and a safety plan according to (3) of the craft.
2. These safety instructions shall include information on at least the following measures:
  - a) emergency shutdown of the system,
  - b) measures in the event of accidental release of liquid or gaseous fuel, for instance during bunkering,
  - c) measures in the event of fire or other incidents on board,
  - d) measures in the event of collision,
  - e) use of safety equipment,
  - f) raising the alert, and
  - g) evacuation.
3. The safety plan shall include information on at least the following areas and equipment:
  - a) hazardous areas,
  - b) escape routes, emergency exits and gastight rooms,
  - c) life-saving equipment and ships' boats,
  - d) fire extinguishers, fire-fighting systems and sprinkler systems,
  - e) alarm systems,
  - f) emergency circuit-breakers' controls,
  - g) fire dampers,
  - h) emergency power sources,
  - i) ventilation system controls,
  - j) controls for fuel supply lines, and
  - k) safety equipment.
4. The safety rota shall:
  - a) be duly stamped by the inspection body, and
  - b) be prominently displayed at one or more appropriate points on board.
5. A detailed operating manual of the propulsion ~~and~~ auxiliary system shall be provided on board craft according to Article 30.01, and shall at minimum:
  - a) contain practical explanations about bunkering system, fuel containment system, fuel piping system, fuel supply system, engine or energy converter room, ventilation system, leakage prevention and control, monitoring and safety system,
  - b) describe the bunkering operations, especially valves operation, purging, inerting and gas freeing,
  - c) describe the relevant method of electrical insulation during bunkering operations, and
  - d) describe the details of risks identified in the risk assessment as referred to in Article 30.04 and the means by which they are mitigated.

**Article 30.06**  
**Marking**

Service rooms and system components shall be appropriately marked ~~so that it is clear~~ with a symbol in accordance with the corresponding figure of Annex 4, which clearly shows for what fuels they are being used, with a side length of at least 10 cm.

**Article 30.07**  
**Independent propulsion**

In the event of an automatic shutdown of the propulsion system or parts of the propulsion system, the craft shall be able to make steerageway under its own power.

**Article 30.08**  
**Fire safety**

1. Fire detection, protection and extinction measures appropriate to the hazards concerned shall be provided on board.
2. An appropriate fixed fire alarm system shall be provided for all rooms and spaces of the propulsion and ~~or~~ auxiliary system where fire cannot be excluded.
3. An appropriate firefighting system shall be provided for all rooms and spaces of the propulsion and ~~or~~ auxiliary system.

**Article 30.09**  
**Electrical installations**

1. In accordance with Article 10.04, equipment for hazardous areas shall be of an appropriate type according to zones where such equipment is installed.
2. Electrical generation and distribution systems and associated control systems shall be designed such that a single failure will not result in the release of fuel.
3. The lighting system in hazardous areas shall be divided between at least two branch circuits. All switches and protective devices shall interrupt all poles and phases and shall be located in a non-hazardous area.

**Article 30.10**  
**Control, monitoring and safety systems**

1. ~~Each~~ propulsion ~~and~~ ~~each~~ auxiliary system of craft according to Article 30.01(1) shall be fitted with its own control and monitoring system and its own safety system. These systems must be independent from each other. All elements of these systems shall be capable of being functionally tested.

2. Spaces in which the propulsion or auxiliary system is installed shall be equipped with permanently installed devices for gas detection and leakage monitoring. The number, type and redundancy of detectors in each space shall correspond to the size, layout and ventilation of the space. Permanently installed gas detectors shall be installed where gas may accumulate and in the ventilation outlets of these spaces.
3. Instrumentation devices shall be fitted to allow a local and a remote reading of essential parameters, where they are necessary to ensure a safe operation of the whole system including bunkering.

### **Article 30.11** ***Testing***

1. Propulsion and auxiliary systems of craft according to Article 30.01(1) shall be inspected by the inspection body:
  - a) before commissioning,
  - b) after any modification or repair, and
  - c) regularly, at least once a year.

The relevant instructions of the manufacturers shall be taken into account in the process.

2. The inspections referred to in (1)(a) and (c), must at least cover:
  - a) a check of conformity of the propulsion and auxiliary systems with the approved drawings and in the case of subsequent checks, whether alterations in the propulsion or auxiliary system were made,
  - b) if necessary, a functional test of the propulsion and auxiliary systems for all operational possibilities,
  - c) a visual check and a tightness check of all system components, in particular valves, pipelines, hoses, pistons, pumps and filters,
  - d) a visual check of the electrical and electronic appliances of the installation, and
  - e) a check of the control, monitoring, and safety systems.
3. The inspections referred to in (1)(b) shall include at least the parts of (2) which have been modified or repaired.
4. For each inspection according to (1), an inspection attestation shall be issued showing the date of inspection.”

58. *Article 31.02 is amended as follows:*

- a) *(2) (concerns only the French version)*
- b) *(5) (concerns only the French version)*
- c) *(6) (concerns only the French version)*

59. The table in Article 32.02(2) is amended as follows:

a) The notes relating to Article 3.03(2) are worded as follows:

“

Article and paragraph		Content	Deadline and comments	
	(2)	Accommodation aft of the aft-peak bulkhead	N.R.C., at the latest on renewal of the inland navigation vessel certificate after	1.1.2045
		<del>Safety equipment forward of the collision bulkhead</del>	<del>N.R.C., at the latest on renewal of the inland navigation vessel certificate after</del>	<del>1.1.2015</del>
		Safety equipment aft of the aft-peak bulkhead	N.R.C., at the latest on renewal of the inland navigation vessel certificate after	1.1.2035

”

b) The note relating to Article 5.06(1), 1<sup>st</sup> sentence, is worded as follows:

“

Article and paragraph		Content	Deadline and comments	
5.06	(1) 1st sentence	Minimum speed	<del>N.R.C., For craft which were laid down before 1.1.1996,</del> at the latest on renewal of the inland navigation vessel certificate after	1.1.2035

”

c) The note relating to Article 6.01(7) is deleted:

“

Article and paragraph		Content	Deadline and comments	
	<del>(7)</del>	<del>Design of rudder stocks</del>	<del>N.R.C., at the latest on renewal of the inland navigation vessel certificate after</del>	<del>1.1.2015</del>

”

d) The notes relating to Articles 6.06 and 6.08 are deleted:

“

Article and paragraph		Content	Deadline and comments	
6.06	(1)	Two independent steering controls	N.R.C., at the latest on renewal of the inland navigation vessel certificate after	1.1.2015
6.08	(1)	Requirements for electrical equipment according to Article 10.20	N.R.C., at the latest on renewal of the inland navigation vessel certificate after	1.1.2015

”

e) The note relating to Article 7.02(3) 2<sup>nd</sup> subparagraph is deleted:

“

Article and paragraph		Content	Deadline and comments	
7.02	(3) 2 <sup>nd</sup> subparagraph	Unobstructed view in the helmsman's usual axis of vision	N.R.C., at the latest on renewal of the inland navigation vessel certificate after	1.1.2015

”

f) The note relating to Article 7.03(7) is deleted:

“

Article and paragraph		Content	Deadline and comments	
7.03	(7)	Shutdown of alarms	N.R.C., at the latest on renewal of the inland navigation vessel certificate, unless the wheelhouse steering position has been designed for radar navigation by one person.	

”



g) The note relating to Article 7.04(2) is worded as follows:

“

<i>Article and paragraph</i>		<i>Content</i>	<i>Deadline and comments</i>	
7.04	(2)	Control of each main engine	Unless wheelhouses steering positions have been designed for radar navigation by one person: N.R.C., at the latest on renewal of the inland navigation vessel certificate after	1.1.2035 if the direction of motion can be achieved directly 1.1.2010 for other engines

”

h) The notes relating to Article 7.06(2) and (3) are worded as follows:

“

Article and paragraph	Content	Deadline and comments	
(2)	Inland ECDIS equipment being operated in navigation mode	Inland ECDIS equipment with a type-approval according to Edition 2.4 (or previous ones) <del>previous editions</del> of the Inland ECDIS Standard, ES-RIS 2021/1 or ES-RIS 2023/1, and installed before the 1st January 2024 may continue to be used.	
		Inland ECDIS equipment with a type-approval according to Edition 2.4 (or previous ones) <del>previous editions</del> of the Inland ECDIS Standard, ES-RIS 2021/1 or ES-RIS 2023/1, may continue to be installed then be used, when the current edition of the presentation library and the feature catalogue as required by ES-RIS (parts I and V) <del>Inland ECDIS Standard</del> has been implemented in the equipment.	
	Inland ECDIS equipment being operated in navigation mode and which have received an approval based on European standard EN 302 194-1 : 2006	Inland ECDIS equipment which has received an approval based on European standard EN 302 194-1 : 2006 before 31 December 2023, may continue to be installed then be used if there is a valid installation certificate pursuant to this Standard.	
(3)	Inland AIS equipment	Inland AIS equipment with a type-approval according to edition 1.0 and 1.01 of the Test Standard for Inland AIS and installed before the 1 <sup>st</sup> December 2015 may continue to be used.	
		Inland AIS equipment with a type-approval according to edition 2.0 of the Test Standard for Inland AIS and installed before the 1 <sup>st</sup> January 2024 may continue to be used.	
		Inland AIS equipment with a type-approval according to edition 2021/3.0 of the Test Standard for Inland AIS, ES-RIS 2021/1 or ES-RIS 2023/1, may continue to be installed then be used.	

“

i) The notes relating to Article 7.12 are worded as follows:

“

Article and paragraph		Content	Deadline and comments	
7.12	(4) 3 <sup>rd</sup> sentence	Roof opening used as an emergency exit	N.R.C., at the latest on renewal of the inland navigation vessel certificate after	1.1.2035
	(45) 2 <sup>nd</sup> sentence	Indications	N.R.C., at the latest on renewal of the inland navigation vessel certificate.	
	(56)	Stopping, locking and automatic deactivation	N.R.C., at the latest on renewal of the inland navigation vessel certificate after	1.1.2025
	(78) 1 <sup>st</sup> and 2 <sup>nd</sup> sentences	Arrangements and protection features	N.R.C., at the latest on renewal of the inland navigation vessel certificate after	1.1.2025
	(8) 3 <sup>rd</sup> sentence	Symbol and warning device	N.R.C., at the latest on renewal of the inland navigation vessel certificate.	
	(78) 3 <sup>rd</sup> 4 <sup>th</sup> sentence	Optical warning signal	N.R.C., at the latest on renewal of the inland navigation vessel certificate.	
	(89)	Emergency lowering system for lifting mechanisms which are not hydraulic	<del>If hydraulic lowering is not possible:</del> N.R.C., at the latest on renewal of the inland navigation vessel certificate after	1.1.2040
	(12)(c)	Testing	<del>N.R.C., at the latest on renewal of the inland navigation vessel certificate.</del> <del>If mathematical proof cannot be provided, the inspection body may recognise other suitable proof as equivalent.</del>	

”

j) The note relating to Article 7.14 is worded as follows:

Article and paragraph		Content	Deadline and comments	
7.14	(2) to (8)	Retractable wheelhouses	N.R.C.	
	(3) 2 <sup>nd</sup> sentence	Enter and leave the wheelhouse, whatever its position	N.R.C., at the latest on renewal of the inland navigation vessel certificate.	
	(3) 3 <sup>rd</sup> sentence	Dimensions of the opening in the roof	N.R.C., at the latest on renewal of the inland navigation vessel certificate after	1.1.2035
	(4)	Stopping, locking and automatic deactivation	N.R.C.	
	(5)	No exceeding of terminal position	N.R.C., at the latest on renewal of the inland navigation vessel certificate.	
	(6) 1 <sup>st</sup> and 2 <sup>nd</sup> sentences	Arrangements and protection features	N.R.C.	
	(7)	Hydraulic hoses	N.R.C., at the latest on renewal of the inland navigation vessel certificate.	

k) The note relating to Article 8.01(3) is deleted:

Article and paragraph		Content	Deadline and comments	
8.01	(3)	Only internal combustion engines burning fuels having a flashpoint of more than 55 °C	N.R.C., at the latest on renewal of the inland navigation vessel certificate after	1.1.2015

l) The note relating to Article 8.03(5) is deleted:

"

Article and paragraph		Content	Deadline and comments	
8.03	(5)	Design of shaft bushing	N.R.C., at the latest on renewal of the inland navigation vessel certificate after	1.1.2015

"

m) The notes relating to Article 8.05(1), (7) 1<sup>st</sup> sentence and (13) are deleted:

"

Article and paragraph		Content	Deadline and comments	
8.05	(1)	Steel tanks for liquid fuels	N.R.C., at the latest on renewal of the inland navigation vessel certificate after	1.1.2015
	(3)	No fuel tanks aft of the aft-peak bulkhead	N.R.C., at the latest on renewal of the inland navigation vessel certificate after	1.1.2035
	(6), 3 <sup>rd</sup> to 5 <sup>th</sup> sentences	Installation and measurements of breather pipes and connection pipes	N.R.C., at the latest on renewal of the inland navigation vessel certificate after	1.1.2020
	(7), 1 <sup>st</sup> sentence	Quick-closing valve on the tank operated from deck, even when the rooms in question are closed	N.R.C., at the latest on renewal of the inland navigation vessel certificate after	1.1.2015
	(13)	Filling level control not only for main engines but also other engines needed for safe operation of the vessel	N.R.C., at the latest on renewal of the inland navigation vessel certificate after	1.1.2015

"

n) The note relating to Article 10.05(4) is deleted:

"

Article and paragraph		Content	Deadline and comments	
10.05	(4)	Cross-section of earthing conductors	N.R.C., at the latest on renewal of the inland navigation vessel certificate after	1.1.2015

"

o) The note relating to Article 10.11(15) is worded as follows:

"

Article and paragraph		Content	Deadline and comments	
10.11	(15)	European Standards EN 62619 and EN 62620 for lithium-ion accumulators	N.R.C., Lithium-ion accumulators installed before 7.10.2018 shall comply with the requirements of European Standards EN 62619 and EN 62620 at the latest on renewal of the inland navigation vessel certificate after	1.1.2025

"

p) The note relating to Article 10.12(2)(d) is deleted:

"

Article and paragraph		Content	Deadline and comments	
10.12	(2)(d)	Direct power supply for consumer equipment for propelling and manoeuvring	N.R.C., at the latest on renewal of the inland navigation vessel certificate after	1.1.2015

"

q) The note relating to Article 10.16(3) 2<sup>nd</sup> sentence is deleted:

"

Article and paragraph		Content	Deadline and comments	
10.16	<del>(3) second sentence</del>	Second circuit	N.R.C., at the latest on renewal of the inland navigation vessel certificate after	1.1.2015

"

r) The note relating to Article 10.19 is deleted:

"

Article and paragraph		Content	Deadline and comments	
10.19		<del>Alarm and safety systems for mechanical installations</del>	N.R.C., at the latest on renewal of the inland navigation vessel certificate after	1.1.2015

"

s) The note relating to Chapter 11 is worded as follows:

"

Article and paragraph	Content	Deadline and comments	
	<b>CHAPTER 11</b>	N.R.C. However, electric propulsion systems installed between 1.1.2020 and 1.1.2026 shall comply at least with the Chapter 11 in ES-TRIN 2019/1.	

"

t) The notes relating to Article 15.02(11)(c) and (d) are worded as follows:

"

Article and paragraph		Content	Deadline and comments	
	(11)(c)	Doors which are located along escape routes	N.R.C., at the latest on renewal of the inland navigation vessel certificate after	1.1.2052
	(11)(d)	Doors which are locked from the inside	N.R.C., at the latest on renewal of the inland navigation vessel certificate after	1.1.2027

"

u) The note relating to Article 15.05(1), 2<sup>nd</sup> sentence, is added after the note relating to Article 15.04 as follows:

"

Article and paragraph		Content	Deadline and comments	
15.05	(1) 2 <sup>nd</sup> sentence	Filler neck of the potable water tanks	N.R.C., at the latest on renewal of the inland navigation vessel certificate.	

"



v) The notes relating to Article 18.01 are worded as follows:

“

Article and paragraph		Content	Deadline and comments	
18.01	(2), Tables 1 and 2, and (7 <del>5</del> )	Limit/control values and type-approvals	N.R.C., as long as	
			a) the limit and control values do not exceed the double values according to values of step II by more than the factor 2,	
			b) the on-board sewage treatment plant has a manufacturer's or expert's certificate confirming that it can cope with the typical loading patterns on board the craft, and	
			<del>c) a system of sewage sludge management is in place for it which is appropriate to the conditions of operating a sewage treatment plant aboard a passenger vessel.</del>	
			On-board sewage treatment plants which have received an approval on or after 1 <sup>st</sup> December 2011, pursuant to requirements of the Resolution CCNR 2010-II-27 (Step II), may continue to be installed and used.	
			On-board sewage treatment plants which have received an approval on or after 10 January 2013, pursuant to requirements of the Directive 2012/49/EU (Step II), may continue to be installed and used.	
	(9)	Sampling point	N.R.C., at the latest on renewal of the inland navigation vessel certificate.	

“

w) The note relating to Article 18.11 is added after the notes relating to Article 18.01 as follows:

“

Article and paragraph		Content	Deadline and comments	
18.11		Operation management manual	N.R.C., at the latest on renewal of the inland navigation vessel certificate.	

”

x) The note relating to Article 19.02(1a) is inserted before the note relating to Article 19.02(2) as follows:

“

Article and paragraph		Content	Deadline and comments	
19.02	(1a)	Materials other than steel, such as aluminium alloy or Fibre Reinforced Plastic composites	N.R.C.	

”

y) The note relating to Article 19.02(10)(c) is deleted:

“

Article and paragraph		Content	Deadline and comments	
	(10)(c)	Time for closure process	<del>N.R.C., at the latest on renewal of the inland navigation vessel certificate after</del>	<del>1.1.2015</del>

”

z) The note relating to Article 19.02(10)(d) (concerns only the French version)

aa) The note relating to Article 19.06(7) is deleted:

“

Article and paragraph		Content	Deadline and comments	
	(7)	Suitable safety guidance system	N.R.C., at the latest on renewal of the inland navigation vessel certificate after	1.1.2015

”

bb) The note relating to Article 19.06(15) (concerns only the French version)

cc) The notes relating to Article 19.08(6) and (10) are deleted:

“

Article and paragraph		Content	Deadline and comments	
19.08	(6)	Permanently installed bilge system	N.R.C., at the latest on renewal of the inland navigation vessel certificate after	1.1.2015
	(8) last sentence	Independent ventilation system	N.R.C., at the latest on renewal of the inland navigation vessel certificate after	1.1.2044
	(10)	Automated external defibrillator	N.R.C., at the latest on renewal of the inland navigation vessel certificate.	

”

dd) The notes relating to Article 19.10 are deleted:

Article and paragraph		Content	Deadline and comments	
19.10	(2)	Article 10.16(3) also applicable to passageways and recreation rooms for passengers	N.R.C., at the latest on renewal of the inland navigation vessel certificate after	1.1.2015
	(3)	Adequate emergency lighting	N.R.C., at the latest on renewal of the inland navigation vessel certificate after	1.1.2015
	(4)	Emergency power plant	For day-trip vessels with $L_{max}$ of 25 m or less, the provision applies at N.R.C., at the latest on renewal of the inland navigation vessel certificate after	1.1.2015
	(4)(f)	Emergency supply for searchlights according to Article 13.02(2)(i)	N.R.C., at the latest on renewal of the inland navigation vessel certificate after	1.1.2015
	(4)(i)	Emergency supply for lifts and lifting equipment according to Article 19.06(9), second sentence	N.R.C., at the latest on renewal of the inland navigation vessel certificate after	1.1.2015
	(6) 1 <sup>st</sup> sentence	Partitions according to Article 19.11(2).	N.R.C., at the latest on renewal of the inland navigation vessel certificate after	1.1.2015
	(6) 2 <sup>nd</sup> and 3 <sup>rd</sup> sentence	Installation of cables	N.R.C., at the latest on renewal of the inland navigation vessel certificate after	1.1.2015
	(6) 4 <sup>th</sup> sentence	Emergency power plant above the margin line	N.R.C., at the latest on renewal of the inland navigation vessel certificate after	1.1.2015

“

ee) The note relating to Article 19.11(3) is deleted:

“

Article and paragraph		Content	Deadline and comments	
	(3)	Paints, lacquers and other surface treatment products as well as deck coverings used in rooms except engine rooms and store rooms shall be flame-retardant	N.R.C., at the latest on renewal of the inland navigation vessel certificate after	1.1.2015

“

ff) The note relating to Article 19.12(9) is deleted:

“

Article and paragraph		Content	Deadline and comments	
	(9)	Fire-extinguishing system in engine rooms	N.R.C., at the latest on renewal of the inland navigation vessel certificate after	1.1.2015

“

gg) The note relating to Chapter 25 is deleted:

“

Article and paragraph		Content	Deadline and comments	
<b>CHAPTER 25</b>				
25.01		Application of Articles 7.01(2), 7.04(11)(e) 8.05(13) and 8.10	For seagoing vessels not intended for the carriage of substances referred to in the ADN and the keel of which was laid before 1.10.1987: N.R.C., at the latest on renewal of the inland navigation vessel certificate after	1.1.2015

“

60. The table in Article 32.03(2) is amended as follows:

a) The notes relating to Chapter 4 and Chapter 8 are deleted:

Article and paragraph		Content	Deadline and comments	
<b>CHAPTER 4</b>				
4.01	(4)	Safety clearance	Renewal of the inland navigation vessel certificate after	1.1.2015
4.02		Freeboard	Renewal of the inland navigation vessel certificate after	1.1.2015
<b>CHAPTER 8</b>				
8.08	(3) and (4)	Minimum pumping capacity and internal diameter of drainage pipes	Renewal of the inland navigation vessel certificate after	1.1.2015

b) The notes relating to Articles 10.03, 10.06, 10.10, 10.11, 10.12, 10.13, 10.14, 10.15 and 10.17 are deleted:

Article and paragraph		Content	Deadline and comments	
10.03		Type of protection according to installation location	R.C., at the latest on renewal of the inland navigation vessel certificate after	1.1.2015
10.06	(4) table without footnote 4	Maximum permissible voltages	R.C., at the latest on renewal of the inland navigation vessel certificate after	1.1.2015
10.10		Generators, engines and transformers	R.C., at the latest on renewal of the inland navigation vessel certificate after	1.1.2015
10.11	(3) and (5)	Installation of accumulators	R.C., at the latest on renewal of the inland navigation vessel certificate after	1.1.2015
10.12		Switchgear and controlgear	R.C., at the latest on renewal of the inland navigation vessel certificate after	1.1.2015
10.13		Emergency circuit breaker devices	R.C., at the latest on renewal of the inland navigation vessel certificate after	1.1.2015
10.14		Installation fittings	R.C., at the latest on renewal of the inland navigation vessel certificate after	1.1.2015
10.15	(1) to (10)	Cables	R.C., at the latest on renewal of the inland navigation vessel certificate after	1.1.2015
10.17		Navigation lights	R.C., at the latest on renewal of the inland navigation vessel certificate after	1.1.2015

61. The table in Article 32.05(5) is amended as follows:

a) The notes relating to Article 7.06(2) and (3) are worded as follows:

Article and paragraph	Content	Deadline and comments	Date of entry into force
(2)	Inland ECDIS equipment being operated in navigation mode	Inland ECDIS equipment with a type-approval according to Edition 2.4 (or previous ones) <del>previous editions</del> of the Inland ECDIS Standard, ES-RIS 2021/1 or ES-RIS 2023/1, and installed before the 1st January 2026 <del>2</del> may continue to be used.	1.1.2026 <del>2</del>
		<del>Inland ECDIS equipment with a type-approval according to edition 2.4 of the Inland ECDIS Standard and installed before the 1<sup>st</sup> January 2024 may continue to be used.</del>	1.1.2024
		Inland ECDIS equipment with a type-approval according to Edition 2.4 (or previous ones) <del>previous editions</del> of the Inland ECDIS Standard, ES-RIS 2021/1 or ES-RIS 2023/1, may continue to be installed then be used, when the current edition of the presentation library and the feature catalogue as required by ES-RIS (Parts I and V) <del>Inland ECDIS Standard</del> has been implemented in the equipment.	1.1.2026 <del>2</del>
	Inland ECDIS equipment being operated in navigation mode and which has received an approval based on European standard EN 302 194-1 : 2006	Inland ECDIS equipment which has received an approval based on European standard EN 302 194-1 : 2006 before 31 December 2023, may continue to be installed then be used if there is a valid installation certificate pursuant to this Standard.	1.1.2024
(3)	Inland AIS equipment	Inland AIS equipment with a type-approval according to edition 1.0 and 1.01 of the Test Standard for Inland AIS and installed before the 1st December 2015 may continue to be used.	1.12.2013
		Inland AIS equipment with a type-approval according to edition 2.0 of the Test Standard for Inland AIS and installed before the 1st January 2024 may continue to be used.	1.1.2022
		Inland AIS equipment with a type-approval according to edition 2021/3.0 of <del>the Test Standard for Inland AIS</del> , ES-RIS 2021/1 or ES-RIS 2023/1 may continue to be installed then be used.	1.1.2026 <del>4</del>

b) The notes relating to Article 7.12 are worded as follows:

Article and paragraph		Content	Deadline and comments		Date of entry into force
7.12	(45) 2 <sup>nd</sup> sentence	Indications	N.R.C., at the latest on renewal of the inland navigation vessel certificate.		7.10.2018
	(56)	Stopping, locking and automatic deactivation	N.R.C., at the latest on renewal of the inland navigation vessel certificate after	1.1.2025	7.10.2018
	(78) 1 <sup>st</sup> and 2 <sup>nd</sup> sentences	Arrangements and protection features	N.R.C., at the latest on renewal of the inland navigation vessel certificate after	1.1.2025	7.10.2018
	(8) 3 <sup>rd</sup> sentence	Symbol and warning device	N.R.C., at the latest on renewal of the inland navigation vessel certificate.		1.1.2026
	(78) 3 <sup>rd</sup> 4 <sup>th</sup> sentence	Optical warning signal	N.R.C., at the latest on renewal of the inland navigation vessel certificate.		7.10.2018
	(89)	Emergency lowering system for lifting mechanisms which are not hydraulic	<del>If hydraulic lowering is not possible:</del> N.R.C., at the latest on renewal of the inland navigation vessel certificate after	1.1.2040	7.10.2018
	(42)(c)	Testing	<del>N.R.C., at the latest on renewal of the inland navigation vessel certificate.</del> <del>If mathematical proof cannot be provided, the inspection body may recognise other suitable proof as equivalent.</del>		7.10.2018

“



c) The note relating to Article 7.14 is worded as follows:

Article and paragraph	Content	Deadline and comments		Date of entry into force	
7.14	(2) to (8)	Retractable wheelhouses	N.R.C.		1.1.2024
	(3) 2 <sup>nd</sup> sentence	Enter and leave the wheelhouse, whatever its position	N.R.C., at the latest on renewal of the inland navigation vessel certificate.		
	(3) 3 <sup>rd</sup> sentence	Dimensions of the opening in the roof	N.R.C., at the latest on renewal of the inland navigation vessel certificate after	1.1.2035	
	(4)	Stopping, locking and automatic deactivation	N.R.C.		
	(5)	No exceeding of terminal position	N.R.C., at the latest on renewal of the inland navigation vessel certificate.		
	(6) 1 <sup>st</sup> and 2 <sup>nd</sup> sentences	Arrangements and protection features	N.R.C.		
	(7)	Hydraulic hoses	N.R.C., at the latest on renewal of the inland navigation vessel certificate.		

d) The notes relating to Article 8.05(7) 1<sup>st</sup> sentence and (13) are deleted:

“

Article and paragraph		Content	Deadline and comments		Date of entry into force
	<del>(7), 1<sup>st</sup> sentence</del>	<del>Quick-closing valve on the tank operated from deck, even when the rooms in question are closed</del>	<del>N.R.C., at the latest on renewal of the inland navigation vessel certificate after</del>	<del>1.1.2015</del>	<del>1.4.2008</del>
	<del>(13)</del>	<del>Filling level control not only for main engines but also other engines needed for safe operation of the vessel</del>	<del>N.R.C., at the latest on renewal of the inland navigation vessel certificate after</del>	<del>1.1.2015</del>	<del>1.4.1999</del>

“

e) The note relating to Article 10.11(15) is worded as follows:

“

Article and paragraph		Content	Deadline and comments		Date of entry into force
10.11	(15)	European Standards EN 62619 and EN 62620 for lithium-ion accumulators	<del>N.R.C.,</del> Lithium-ion accumulators installed before 7.10.2018 shall comply with the requirements of European Standards EN 62619 and EN 62620 at the latest on renewal of the inland navigation vessel certificate after	1.1.2028 <del>5</del>	7.10.2018

“

f) The note relating to Article 10.16(3) 2<sup>nd</sup> sentence is deleted:

“

Article and paragraph		Content	Deadline and comments		Date of entry into force
<del>10.16</del>	<del>(3), second sentence</del>	<del>Second circuit</del>	<del>N.R.C., at the latest on renewal of the inland navigation vessel certificate after</del>	<del>1.1.2015</del>	<del>7.10.2018</del>

“

g) The note relating to Article 10.19 is deleted:

“

Article and paragraph		Content	Deadline and comments		Date of entry into force
10.19		<del>Alarm and safety systems for mechanical installations</del>	<del>N.R.C., at the latest on renewal of the inland navigation vessel certificate after</del>	1.1.2015	7.10.2018

“

h) The note relating to Chapter 11 is worded as follows:

“

Article and paragraph		Content	Deadline and comments		Date of entry into force
CHAPTER 11			N.R.C.		1.1.2020 1.1.2026
			However, electric propulsion systems installed between 1.1.2020 and 1.1.2026 shall comply at least with the Chapter 11 in ES-TRIN 2019/1.		

“

i) The note relating to Article 13.02(2)(b) is deleted:

“

Article and paragraph		Content	Deadline and comments		Date of entry into force
13.02	(2)(b)	<del>Receptacles made of steel or another sturdy, non flammable material and holding at least 10 litres</del>	<del>N.R.C., at the latest on renewal of the inland navigation vessel certificate.</del>		1.12.2011

“

j) The notes relating to Article 15.02(11)(c) and (d) are worded as follows:

Article and paragraph		Content	Deadline and comments		Date of entry into force
15.02	(11)(c)	Doors which are located along escape routes	N.R.C., at the latest on renewal of the inland navigation vessel certificate after	1.1.2052	1.1.2022
	(11)(d)	Doors which are locked from the inside	N.R.C., at the latest on renewal of the inland navigation vessel certificate after	1.1.2027	1.1.2022

k) The note relating to Article 15.05(1), 2<sup>nd</sup> sentence, is added after the note relating to Article 15.02(11)(d) as follows:

Article and paragraph		Content	Deadline and comments		Date of entry into force
15.05	(1), 2 <sup>nd</sup> sentence	Filler neck of the potable water tanks	N.R.C., at the latest on renewal of the inland navigation vessel certificate.		1.1.2026

l) The notes relating to Article 18.01 are worded as follows:

Article and paragraph		Content	Deadline and comments	Date of entry into force
18.01	(2), Tables 1 and 2, and (7 <del>5</del> )	Limit/control values and type-approvals	N.R.C., as long as	1.12.2011
			a) the limit and control values do not exceed the double values according to values of step II <del>by more than the factor 2,</del>	
			b) the on-board sewage treatment plant has a manufacturer's or expert's certificate confirming that it can cope with the typical loading patterns on board the craft, <del>and</del>	
		<del>c) a system of sewage sludge management is in place for it which is appropriate to the conditions of operating a sewage treatment plant aboard a passenger vessel.</del>		
		On-board sewage treatment plants which have received an approval on or after 1 <sup>st</sup> December 2011, pursuant to requirements of the Resolution CCNR 2010-II-27 (Step II), may continue to be installed and used.		7.10.2018
		On-board sewage treatment plants which have received an approval on or after 10 January 2013, pursuant to requirements of the Directive 2012/49/EU (Step II), may continue to be installed and used.		7.10.2018
	(9)	Sampling point	N.R.C., at the latest on renewal of the inland navigation vessel certificate.	1.1.2026

m) The note relating to Article 18.11 is added after the notes relating to Article 18.01 as follows:

Article and paragraph		Content	Deadline and comments		Date of entry into force
18.11		Operation management manual	N.R.C., at the latest on renewal of the inland navigation vessel certificate.		1.1.2026

n) The note relating to Article 19.02(1a) is inserted before the note relating to Article 19.02(2) as follows:

Article and paragraph		Content	Deadline and comments		Date of entry into force
19.02	(1a)	Materials other than steel, such as aluminium alloy or Fibre Reinforced Plastic composites	N.R.C.		1.1.2024

o) The note relating to Article 19.02(10)(d) (concerns only the French version)

p) The note relating to Article 19.06(7) is deleted:

Article and paragraph		Content	Deadline and comments		Date of entry into force
	(7)	Suitable safety guidance system	N.R.C., at the latest on renewal of the inland navigation vessel certificate after	1.1.2015	1.1.2006

q) The note relating to Article 19.06(15) (concerns only the French version)

r) The notes relating to Article 19.08(6) and (10) are deleted:

Article and paragraph		Content	Deadline and comments		Date of entry into force
19.08	<del>(6)</del>	<del>Permanently installed bilge system</del>	<del>N.R.C., at the latest on renewal of the inland navigation vessel certificate after</del>	<del>1.1.2015</del>	<del>1.1.2006</del>
	(8) last sentence	Independent ventilation system	N.R.C., at the latest on renewal of the inland navigation vessel certificate after	1.1.2044	1.1.2024
	<del>(10)</del>	<del>Automated external defibrillator</del>	<del>N.R.C., at the latest on renewal of the inland navigation vessel certificate.</del>		<del>1.1.2020</del>

s) The notes relating to Article 19.10 are deleted:

Article and paragraph		Content	Deadline and comments		Date of entry into force
19.10	(2)	<del>Article 10.16(3) also applicable to passageways and recreation rooms for passengers</del>	<del>N.R.C., at the latest on renewal of the inland navigation vessel certificate after</del>	<del>1.1.2015</del>	<del>1.1.2006</del>
	(3)	<del>Adequate emergency lighting</del>	<del>N.R.C., at the latest on renewal of the inland navigation vessel certificate after</del>	<del>1.1.2015</del>	<del>1.1.2006</del>
	(4)	<del>Emergency power plant</del>	<del>For day-trip vessels with <math>L_{WLE}</math> of 25 m or less, the provision applies at N.R.C., at the latest on renewal of the inland navigation vessel certificate after</del>	<del>1.1.2015</del>	<del>1.1.2006</del>
	(4) (f)	<del>Emergency supply for searchlights according to Article 13.02 (2)(i)</del>	<del>N.R.C., at the latest on renewal of the inland navigation vessel certificate after</del>	<del>1.1.2015</del>	<del>1.1.2006</del>
	(4) (i)	<del>Emergency supply for lifts and lifting equipment according to Article 19.06(9), second sentence</del>	<del>N.R.C., at the latest on renewal of the inland navigation vessel certificate after</del>	<del>1.1.2015</del>	<del>1.1.2006</del>
	(6) 1 <sup>st</sup> sentence	<del>Partitions according to Article 19.11(2)</del>	<del>N.R.C., at the latest on renewal of the inland navigation vessel certificate after</del>	<del>1.1.2015</del>	<del>1.1.2006</del>
	(6) 2 <sup>nd</sup> and 3 <sup>rd</sup> sentences	<del>Installation of cables</del>	<del>N.R.C., at the latest on renewal of the inland navigation vessel certificate after</del>	<del>1.1.2015</del>	<del>1.1.2006</del>
	(6) 4 <sup>th</sup> sentence	<del>Emergency power plant above the margin line</del>	<del>N.R.C., at the latest on renewal of the inland navigation vessel certificate after</del>	<del>1.1.2015</del>	<del>1.1.2006</del>



t) The note relating to Article 19.11(3) is deleted:

“

Article and paragraph		Content	Deadline and comments		Date of entry into force
	(3)	Paints, lacquers and other surface treatment products as well as deck coverings used in rooms except engine rooms and store rooms shall be flame-retardant	N.R.C., at the latest on renewal of the inland navigation vessel certificate after	1.1.2015	1.1.2006

”

u) The notes relating to Article 19.12 are deleted:

“

Article and paragraph		Content	Deadline and comments		Date of entry into force
19.12	(8)(d)	Installation of fire extinguishing pumps	N.R.C., at the latest on renewal of the inland navigation vessel certificate after	1.1.2020	7.10.2018
	(9)	Fire extinguishing system in engine rooms	N.R.C., at the latest on renewal of the inland navigation vessel certificate after  The transitional provision does not apply to passenger vessels which have been laid down after 31.12.1995, the hull of which is made of wood, aluminium or plastic and the engine rooms of which are not made of a material according to Article 3.04(3) and (4).	1.1.2015	1.1.2006

”

62. The table in Article 33.02(2) is amended as follows:

a) The notes relating to Article 6.07 are deleted:

"

Article and paragraph		Content	Deadline and comments	
6.07	(2)(a)	Level alarm of the hydraulic tanks and alarm of the service pressure	N.R.C., at the latest on renewal of the inland navigation vessel certificate after	1.1.2026
	(2)(c)	Monitoring of buffer devices	N.R.C., at the latest on renewal of the inland navigation vessel certificate.	

"

b) The note relating to Article 7.04(2) is worded as follows:

"

Article and paragraph		Content	Deadline and comments	
	(2)	Control of each main engine	Unless wheelhouses steering positions have been designed for radar navigation by one person: N.R.C., at the latest on renewal of the inland navigation vessel certificate after	30.12.2049 if the direction of motion can be achieved directly 30.12.2024 for other engines.

"

c) The note relating to Article 7.04(3) is deleted:

"

Article and paragraph		Content	Deadline and comments	
	(3)	Display	<del>Unless wheelhouses steering positions have been designed for radar navigation by one person: N.R.C., at the latest on renewal of the inland navigation vessel certificate after</del>	<del>30.12.2024</del>

"

d) The notes relating to Article 7.04(10)(a), (b) and (c), (10)(d), (e) and (f), (11)(a), (b) and (c), (11)(e) and (11)(f) are inserted after the note relating to Article 7.04 (9)<sup>4<sup>th</sup></sup> sentence as follows:

"

Article and paragraph		Content	Deadline and comments	
7.04	(10)(a), (b) and (c)	Monitoring of operational temperature, lubricating-oil pressure and oil and air pressure	N.R.C., at the latest on renewal of the inland navigation vessel certificate after	30.12.2024
	(10)(d), (e) and (f)	Rotational speed of the propulsion engines, rotational speed of the propulsors, direction of thrust imparted to the vessel by the propulsors	Unless steering positions have been designed for radar navigation by one person: N.R.C., at the latest on renewal of the inland navigation vessel certificate after	30.12.2024
	(11)(a), (b) and (c)	Alarm of operational temperature, lubricating-oil pressure and oil and air pressure	N.R.C., at the latest on renewal of the inland navigation vessel certificate after	30.12.2024
	(11)(e)	Filling level control not only for main engines but also other engines needed for safe operation of the vessel	N.R.C., at the latest on renewal of the inland navigation vessel certificate after	30.12.2029
	(11)(f)	Level alarm of the hydraulic tanks and alarm of the service pressure	N.R.C., at the latest on renewal of the inland navigation vessel certificate after	1.1.2026

"

e) The notes relating to Article 7.06(2) and (3) are worded as follows:

Article and paragraph		Content	Deadline and comments	
	(2)	Inland ECDIS equipment being operated in navigation mode	Inland ECDIS equipment with a type-approval according to Edition 2.4 (or previous ones) <del>previous editions</del> of the Inland ECDIS Standard, ES-RIS 2021/1 or ES-RIS 2023/1, and installed before the 1 <sup>st</sup> January 2024 may continue to be used.	
			Inland ECDIS equipment with a type-approval according to Edition 2.4 (or previous ones) <del>previous editions</del> of the Inland ECDIS Standard, ES-RIS 2021/1 or ES-RIS 2023/1, may continue to be installed then be used, when the current edition of the presentation library and the feature catalogue as required by ES-RIS (parts I and V) <del>Inland ECDIS Standard</del> has been implemented in the equipment.	
		Inland ECDIS equipment being operated in navigation mode, and which has received an approval based on European standard EN 302 194-1 : 2006	Inland ECDIS equipment that has received an approval based on European standard EN 302 194-1 : 2006 before 31 December 2023, may continue to be installed then be used if there is a valid installation certificate pursuant to this Standard.	
	(3)	Inland AIS equipment	N.R.C.	
			Inland AIS equipment with a type-approval according to edition 2.0 of the Test Standard for Inland AIS and installed before the 1st January 2024 may continue to be used.	
			Inland AIS equipment with a type-approval according to edition 2021/3.0 of the Test Standard for Inland AIS, ES-RIS 2021/1 or ES-RIS 2023/1, may continue to be installed then be used	

f) The notes relating to Article 7.12 are worded as follows:

Article and paragraph		Content	Deadline and comments	
7.12	(4) 3 <sup>rd</sup> sentence	Roof opening used as an emergency exit	N.R.C., at the latest on renewal of the inland navigation vessel certificate after	30.12.2049
	(45) 2 <sup>nd</sup> sentence	Indications	N.R.C., at the latest on renewal of the inland navigation vessel certificate.	
	(56)	Stopping, locking and automatic deactivation	N.R.C., at the latest on renewal of the inland navigation vessel certificate after	1.1.2025
	(78) 1 <sup>st</sup> and 2 <sup>nd</sup> sentences	Arrangements and protection features	N.R.C., at the latest on renewal of the inland navigation vessel certificate after	1.1.2025
	(8) 3 <sup>rd</sup> sentence	Symbol and warning device	N.R.C., at the latest on renewal of the inland navigation vessel certificate.	
	(78) 3 <sup>rd</sup> 4 <sup>th</sup> sentence	Optical warning signal	N.R.C., at the latest on renewal of the inland navigation vessel certificate.	
	(89)	Emergency lowering system for lifting mechanisms which are not hydraulic	<del>If hydraulic lowering is not possible-</del> N.R.C., at the latest on renewal of the inland navigation vessel certificate after	1.1.2040
	(12)(c)	Testing	<del>N.R.C., at the latest on renewal of the inland navigation vessel certificate.</del> <del>If mathematical proof cannot be provided, the inspection body may recognise other suitable proof as equivalent.</del>	

g) The note relating to Article 7.14 is worded as follows:

“

Article and paragraph	Content	Deadline and comments	
7.14	(2) to (8) Retractable wheelhouses	N.R.C.	
	(3) 2 <sup>nd</sup> sentence Enter and leave the wheelhouse, whatever its position	N.R.C., at the latest on renewal of the inland navigation vessel certificate.	
	(3) 3 <sup>rd</sup> sentence Dimensions of the opening in the roof	N.R.C., at the latest on renewal of the inland navigation vessel certificate after	1.1.2035
	(4) Stopping, locking and automatic deactivation	N.R.C.	
	(5) No exceeding of terminal position	N.R.C., at the latest on renewal of the inland navigation vessel certificate.	
	(6) 1 <sup>st</sup> and 2 <sup>nd</sup> sentences Arrangements and protection features	N.R.C.	
	(7) Hydraulic hoses	N.R.C., at the latest on renewal of the inland navigation vessel certificate.	

”

h) The notes relating to Article 8.03 are worded as follows:

“

Article and paragraph	Content	Deadline and comments	
8.03	(2) Monitoring devices	N.R.C., at the latest on renewal of the inland navigation vessel certificate after	30.12.2024
	(4)(3) Automatic protection against overspeed display and switch off	N.R.C., at the latest on renewal of the inland navigation vessel certificate after	30.12.2024
	(5)(4) Design of shaft bushings	N.R.C., at the latest on renewal of the inland navigation vessel certificate after	30.12.2029

”

i) The note relating to Article 8.05(13) is deleted:

“

Article and paragraph		Content	Deadline and comments	
	(13)	Filling level control not only for main engines but also other engines needed for safe operation of the vessel	N.R.C., at the latest on renewal of the inland navigation vessel certificate after	30.12.2029

”

j) The note relating to Article 10.11(15) is worded as follows:

“

Article and paragraph		Content	Deadline and comments	
10.11	(15)	European Standards EN 62619 and EN 62620 for lithium-ion accumulators	N.R.C., Lithium-ion accumulators installed before 7.10.2018 shall comply with the requirements of European Standards EN 62619 and EN 62620 at the latest on renewal of the inland navigation vessel certificate after	1.1.2028 <del>5</del>

”

k) The note relating to Article 10.14 is worded as follows:

“

Article and paragraph		Content	Deadline and comments	
10.14	(3), 2 <sup>nd</sup> sentence	Prohibition of single pole switches in laundries, washrooms, <del>bathrooms</del> and other <del>wet</del> rooms with wet facilities	N.R.C., at the latest on renewal of the inland navigation vessel certificate after	30.12.2024

”

l) *The note relating to Chapter 11 is worded as follows:*

“

<i>Article and paragraph</i>	<i>Content</i>	<i>Deadline and comments</i>	
<b>CHAPTER 11</b>		N.R.C. However, electric propulsion systems installed between 1.1.2020 and 1.1.2026 shall comply at least with the Chapter 11 in ES-TRIN 2019/1.	

“

m) *The note relating to Article 13.08(2) (concerns only the German version)*

n) *The notes relating to Article 15.02(11)(c) and (d) are worded as follows:*

“

<i>Article and paragraph</i>	<i>Content</i>	<i>Deadline and comments</i>	
(11)(c)	Doors which are located along escape routes	N.R.C., at the latest on renewal of the inland navigation vessel certificate after	1.1.2052
(11)(d)	Doors which are locked from the inside	N.R.C., at the latest on renewal of the inland navigation vessel certificate after	1.1.2027

“

o) *The current note relating to Article 15.05 is deleted.*

“

<i>Article and paragraph</i>	<i>Content</i>	<i>Deadline and comments</i>	
15.05	Potable water installations	N.R.C., at the latest on renewal of the inland navigation vessel certificate.	

“



p) A new note relating to Article 15.05 (1), 2<sup>nd</sup> sentence, is added after the note relating to 15.04 as follows:

“

Article and paragraph		Content	Deadline and comments
15.05	(1), 2 <sup>nd</sup> sentence	Filler neck of the potable water tanks	N.R.C., at the latest on renewal of the inland navigation vessel certificate.

“

q) The notes relating to Article 18.01 are worded as follows:

“

Article and paragraph		Content	Deadline and comments
18.01	(2) Tables 1 and 2, and (7 <del>5</del> )	Limit/control values and type-approvals	N.R.C., as long as
			a) the limit and control values do not exceed the double values according to values of step II <del>by more than the factor 2,</del>
			b) the on-board sewage treatment plant has a manufacturer's or expert's certificate confirming that it can cope with the typical loading patterns on board the craft. <del>and</del>
			<del>c) a system of sewage sludge management is in place for it which is appropriate to the conditions of operating a sewage treatment plant aboard a passenger vessel.</del>
			On-board sewage treatment plants which have received an approval on or after 1 <sup>st</sup> December 2011, pursuant to requirements of the Resolution CCNR 2010-II-27 (Step II), may continue to be installed and used.
			On-board sewage treatment plants which have received an approval on or after 10 January 2013, pursuant to requirements of the Directive 2012/49/EU (Step II), may continue to be installed and used.
	(9)	Sampling point	N.R.C., at the latest on renewal of the inland navigation vessel certificate.

»

r) The note relating to Article 18.11 is added after the notes relating to Article 18.01 as follows:

Article and paragraph		Content	Deadline and comments
18.11		Operation management manual	N.R.C., at the latest on renewal of the inland navigation vessel certificate.

s) The note relating to Article 19.02(1a) is inserted after the note relating to 19.01(5) and (6):

Article and paragraph		Content	Deadline and comments
19.02	(1a)	Materials other than steel, such as aluminium alloy or Fibre Reinforced Plastic composites	N.R.C.

63. The table in Article 33.03(2) is amended as follows:

a) The note relating to Article 7.05(2) is deleted:

Article and paragraph		Content	Deadline and comments
7.05	(2)	Monitoring of navigation lights	Renewal of the inland navigation vessel certificate.

b) The note relating to Article 8.04 is deleted:

Article and paragraph		Content	Deadline and comments
8.04		Engine exhaust system	N.R.C., at the latest on renewal of the inland navigation vessel certificate.

c) The note relating to Article 10.14(1), (2) and (4) is deleted:

“

Article and paragraph		Content	Deadline and comments	
10.14	(1), (2) and (4)	Installation fittings	R.C., at the latest on renewal of the inland navigation vessel certificate after	1.1.2015

“

64. Annex 3, Section I, is amended as follows:

a) Item 15, table, 2<sup>nd</sup> row, 4<sup>th</sup> column, is worded as follows:

“  
Maximum wetted immersed  
cross-section in m<sup>2</sup>  
”

b) Item 45 is worded as follows:

“45. Special wheelhouse arrangements for radar navigation by one person:  
The vessel has a wheelhouse steering position designed for radar navigation by one person \*).”

c) Item 47, sentence before the table, is worded as follows:

“47. Vessel equipment in accordance with Article 31.01.  
The vessel complies<sup>\*)</sup> / does not comply<sup>\*)</sup> with Article 31.02 (Standard S1)<sup>\*)</sup> / Article 31.03  
(Standard S2)<sup>\*)</sup>.  
[In accordance with Article 3.1819.05 of the Regulations for Rhine navigation personnel / In  
accordance with national or international requirements], the minimum crew needs to be  
increased as follows<sup>\*)</sup> / does not need to be increased<sup>\*)</sup>.”;

d) Item 48, sentence before the table, is worded as follows:

“48. Minimum crew [according to Article 3.1919.06 of the Regulations for Rhine navigation personnel  
/ in accordance with national or international requirements] “.

65. Annex 3, Section II, is amended as follows:

a) Item 6.2, sentence before the table, is worded as follows:



“6.2. Vessel equipment in accordance with Article 31.01.  
The vessel complies<sup>\*)</sup> / does not comply<sup>\*)</sup> with Article 31.02 (Standard S1)<sup>\*)</sup> / Article 31.03  
(Standard S2)<sup>\*)</sup>.  
[In accordance with Article 3.1819.05 of the Regulations for Rhine navigation personnel / In  
accordance with national or international requirements], the minimum crew needs to be  
increased as follows<sup>\*)</sup> / does not need to be increased<sup>\*)</sup>.”.

b) Item 6.3, sentence before the table, is worded as follows:

“6.3. Minimum crew [according to Article 3.1919.06 of the Regulations for Rhine navigation personnel  
/ in accordance with national or international requirements]:”.

66. In Annex 4, Figures 13, 14 and 15 are added after Figure 12 as follows:

“

<p>Figure 13 Warning for areas where explosive atmospheres may occur</p>	 A yellow triangular warning sign with a black border and the text 'Ex' in black.	<p>Colour: black / yellow</p>
<p>Figure 14 Hydrogen warning</p>	 A yellow triangular warning sign with a black border and the text 'H2' in black.	<p>Colour: black / yellow</p>
<p>Figure 15 Methanol warning</p>	 A yellow triangular warning sign with a black border and the text 'MeOH' in black.	<p>Colour: black / yellow</p>

“

67. Annex 5 is amended as follows:

a) Section I, Article 3(3) is worded as follows:

- “3. (2) above does not apply to Inland ECDIS equipment hardware operated in navigation mode in system configuration 2 or 3 in accordance with ES-RIS, part I, chapters 1 and 2 the Inland ECDIS standard, section 1 item 5.2 in conjunction with section 4 item 2.2.2 or 2.2.3 if a manufacturer's certificate of conformity is produced. This certificate of conformity must confirm that the hardware:
- a) is designed and manufactured to withstand the typical stresses and environmental conditions prevailing aboard a vessel, without loss of quality or reliability and
  - b) does not interfere with the operation of other onboard communication and navigation equipment.

The first sentence does not apply to visual display units operated in navigation mode in system configuration 3 nor to hardware components used for providing radar information from the radar processor for display on the Inland ECDIS equipment screen.”

b) *Section I, Article 7(3) (concerns only the French and German versions)*

c) *Section I, Article 9(1) and (2) is worded as follows:*

- “1. Any modification made to equipment already approved shall cause the type-approval to be forfeit.

Whenever modifications are planned, details shall be sent in writing to the competent technical service.

2. The competent authority for the type-approval shall decide following consultation with the technical service whether the type-approval still applies or whether an inspection or new type test is necessary

If a new type-test approval is granted, a new type-approval number shall be assigned.”

d) *Section II, Article 1.06(3) (concerns only the French and Dutch versions)*

e) *Section II, Article 1.08(1) and (2) is worded as follows:*

- “1. Any modification made to equipment already approved shall cause the type-approval to be forfeit.

Whenever modifications are planned, details shall be sent in writing to the competent technical service.

2. The competent authority for the type-approval shall decide following consultation with the technical service whether the type-approval still applies or whether an inspection or new type test is necessary.

If a new type-test approval is granted, a new type-approval number shall be assigned.”

f) *Section II, Article 2.03(2) and (3) are worded as follows:*

- “2. All controls units and indicators shall be provided with symbols and/or markings in English. Symbols shall meet the requirements of International Standard IEC 60417 : 2002 DB (graphical symbols for use on electrical equipment).

All numerals and letters shall be at least 4 mm high. If it can be demonstrated that, for technical reasons, numerals and letters 4 mm high are not possible and if for the purposes of operation smaller numerals and letters are acceptable, a reduction to 3 mm shall be allowed.

3. The equipment shall be designed in such a way that operating mistakes cannot cause its failure.”

g) Section II, Article 3.01, Title (concerns only the French version)

h) Section III is amended as follows:

aa) Article 1(3) is worded as follows:

- “3. ~~All that is permitted to be connected to the navigational radar installations are type-approved external sensors. External sensors connected to the navigational radar installation~~ If data from external sensors for geo-spatial positioning or determining the heading are used by a navigational radar installation, these sensors must be type-approved in accordance with the following maritime Standards:

Sensor	Minimum requirements in accordance with	
	IMO Standard	ISO/IEC Standard
GPS	MSC.112(73) <sup>3</sup>	IEC 61108-1 : 2003
DGPS/DGLONASS	MSC.114(73) <sup>4</sup>	IEC 61108-4 : 2004
Galileo	MSC.233(82) <sup>5</sup>	IEC 61108-3 : 2010
Heading/GPS Compass	MSC.116(73) <sup>6</sup>	ISO 22090-3 : 2014 Part 3: GNSS principles

bb) Article 6 is worded as follows:

**“Article 6**  
*Installation of the position sensor*

For inland ECDIS equipment which is operated in navigation mode, the position sensor (e.g. DGPS/GNSS antenna) must be installed in such a way as to ensure that it operates with the greatest possible degree of accuracy and is not adversely affected by superstructures and transmitting equipment on board ship.”

<sup>3</sup> MSC.112(73) adopted on 1 December 2000- Revised Performance Standards for Shipborne Global Positioning System (GPS) Receiver Equipment.

<sup>4</sup> MSC.114(73) adopted on 1 December 2000 - Revised Performance Standards for Shipborne DGPS and DGLONASS Maritime Radio Beacon Receiver Equipment.

<sup>5</sup> MSC.233(82) adopted on 5 December 2006 - Performance Standards for Shipborne Galileo Receiver Equipment.

<sup>6</sup> MSC.116(73) adopted on 1 December 2000 - Performance Standards for marine transmitting heading devices (THDs).

cc) Article 8 is worded as follows:

**“Article 8**

*Installation and performance certificate*

After successful completion of a test in accordance with Article 7, the competent authority or the approved specialist firm shall issue a certificate based on the model according to Annex 5 Section VI. This certificate shall be kept permanently on board.

If the test conditions have not been met, a list of defects shall be drawn up. Any existing certificate shall be withdrawn or sent to the competent authority ~~or the~~ by the approved specialist firm.”

i) Section IV is worded as follows:

**“Section IV**

***Minimum requirements, requirements for installation and performance tests for Inland AIS equipment in inland navigation***

**Article 1**

*Approval of Inland AIS equipment*

Inland AIS equipment ~~must~~ shall comply with the requirements of ES-RIS, parts II and VI. ~~the Test Standard for Inland AIS,~~ Compliance is proven ~~certified~~ by a ~~an examination of~~ type-approval issued by a competent authority.

**Article 2**

*Installation and performance tests of shipborne Inland AIS equipment*

The following conditions are to be complied with when installing shipborne Inland AIS equipment:

1. Shipborne ~~can~~ Inland AIS equipment ~~can~~ shall only be installed by specialist firms approved by the competent authority.
2. The Inland AIS equipment ~~must~~ shall be installed ~~in the wheelhouse or other readily accessible location.~~ at an appropriate location in such way that
  - a) it does not disturb the operation of other navigation equipment such as navigational radar installations or radiotelephone installations and
  - b) conversely other navigation equipment does not disturb the correct operation of the Inland AIS equipment.
3. The ~~functionality of an internal or external~~ MKD (mMinimum kKeyboard and eDisplay) ~~must~~ shall be accessible to the ~~boatmaster~~ helmsman. The MKD Information ~~warning and Inland AIS equipment status information~~ ~~must~~ shall be located within the helmsman's direct field of view. Other devices used for navigation purposes may however take priority as regards their direct visibility. It shall be possible to establish visually whether the equipment is operating. All warning indicator lights ~~must~~ shall remain visible after installation.



4. ~~It must be possible to establish visually whether the equipment is operating.~~ The equipment ~~is to~~ shall be connected directly to a power supply system in accordance with Article 10.02. The equipment shall feature a power circuit with its own ~~safety device~~ circuit-breaker having regard to Article 10.12(2)(a) and be capable of being ~~provided~~ supplied with power at all times.
5. Inland AIS equipment antennas ~~must~~ shall be installed and properly connected to the equipment ~~stations~~, following the manufacturer's instructions, so as to ensure that ~~these stations~~ this equipment operates reliably under all normal conditions of use. ~~Other equipment may only be connected if the interfaces of the two equipments are compatible.~~ Appropriate cable types shall be used to connect the antennas, taking into account the environmental conditions.

The VHF antenna of the Inland AIS equipment shall:

- a) be omni-directional with a vertical polarization;
- b) be installed in such a way that the potential electromagnetic interference with other high-power energy sources, such as navigational radar installations and other VHF antennas, is as low as technically and physically possible.

Every Inland AIS equipment shall be connected to its own VHF antenna. Sharing the cables of VHF antennas for radiotelephone installations and Inland AIS equipment is not allowed.

The internal GNSS sensor of the Inland AIS equipment shall be connected to a suitable GNSS antenna, even if the Inland AIS equipment is connected to an external GNSS position sensor.

6. ~~All that is permitted to be connected to the Inland AIS equipment are type approved external sensors. External sensors connected to the Inland AIS equipment.~~ If data from external sensors for geo-spatial positioning or determining the heading are used by an Inland AIS equipment, these sensors must be type-approved in accordance with the following maritime Standards:

Sensor	Minimum requirements in accordance with	
	Standard (IMO)	ISO/IEC Standard
GPS	MSC.112(73) <sup>7</sup>	IEC 61108-1 : 2003
DGPS/DGLONASS	MSC.114(73) <sup>8</sup>	IEC 61108-4 : 2004
Galileo	MSC.233(82) <sup>9</sup>	IEC 61108-3 : 2010
Heading/GPS Compass	MSC.116(73) <sup>10</sup>	ISO 22090-3 : 2014 Part 3: GNSS principles

<sup>7</sup> MSC.112(73) adopted on 1 December 2000- Revised Performance Standards for Shipborne Global Positioning System (GPS) Receiver Equipment.

<sup>8</sup> MSC.114(73) adopted on 1 December 2000 - Revised Performance Standards for Shipborne DGPS and DGLONASS Maritime Radio Beacon Receiver Equipment.

<sup>9</sup> MSC.233(82) adopted on 5 December 2006 - Performance Standards for Shipborne Galileo Receiver Equipment.

<sup>10</sup> MSC.116(73) adopted on 1 December 2000 - Performance Standards for marine transmitting heading devices (THDs).

7. If the Inland AIS equipment is connected to the blue panel prescribed by the applicable navigational authority regulations of the Member States, the real state of the blue panel shall be determined and displayed under all normal conditions of use.

The status "not available" shall be used if the blue panel is not connected to the Inland AIS equipment.

78. Before the equipment is put into service after installation ~~Prior to post-installation commissioning~~, in case of periodical inspection in order to extend the validity of the inland navigation certificate, as well as after each modification ~~in the event of the inland navigation vessel certificate being renewed or extended and any conversion~~ of the vessel likely to affect the operating conditions ~~in which this~~ of the equipment ~~operates~~, an installation and performance test shall be carried out by the a competent authority or approved specialist firm ~~must undertake an installation check and operating test~~.

89. The approved specialist firm that has carried out the installation and ~~operating~~ performance test issues a certificate in accordance with Annex 5, Section VI, regarding the specific characteristics and correct operation of the Inland AIS equipment.

910. The certificate ~~must~~ shall be permanently retained onboard.

1011. User instructions ~~must~~ shall be handed over for retention on board. This ~~must~~ shall be mentioned on the shipboard installation certificate.

12. When two Inland AIS equipment are installed on the same vessel, then they shall have corresponding configurations.

13. The requirements laid down in (2), (5), (7) and (12) shall apply only to Inland AIS equipment installed after 1 January 2026, unless the inspection body detects malfunctions in equipment already installed before that date."

j) Section VI is worded as follows:

**“Section VI  
Installation and performance certificate for navigational radar installations, rate-of-turn indicators, for Inland AIS equipment and for tachographs in inland navigation  
(Model)**

Vessel name/type: .....

Unique European vessel identification number: .....

**Vessel owner:**

Name: .....

Address: .....

Telephone: .....

**Navigational radar installations:**

Number: .....

Item No	Type	Manufacturer	Type-approval number	Serial number

**Rate-of-turn indicators:**

Number: .....

Item No	Type	Manufacturer	Type-approval number	Serial number

**Inland AIS equipment:**

Item No	Type	Manufacturer	Type-approval number	Serial number

**Tachographs**

...

It is hereby certified that the vessel's navigational radar installations, rate-of-turn indicators and Inland AIS equipment, referred to above, comply with the requirements of Annex 5 of the European Standard laying down technical requirements for inland navigation vessels (ES-TRIN) for the installation and performance testing of navigational radar installations, rate-of-turn indicators and Inland AIS equipment for inland navigation.

**Approved specialist firm**

Name: .....

Address: .....

Telephone: .....

Stamp

Place .....

Date .....

Signature

**Competent authority for the approval of the specialist firm**

Name: .....

Address: .....

Telephone: .....“

68. Annex 6 is worded as follows:

**“ANNEX 6  
(LEFT VOID)”**

69. Annex 7 is amended as follows:

a) The table of contents is worded as follows:

**“ANNEX 7  
ON-BOARD SEWAGE TREATMENT PLANTS**

**Table of contents**

**Section I** Supplementary provisions

1. Marking of on-board sewage treatment plants
2. Testing
3. Evaluation of conformity of production

**Section II** Information document No ... relating to type-approval of on-board sewage treatment plants intended for installation in inland waterway vessels (model)

Appendix 1 - Main characteristics of the on-board sewage treatment plant type (model)

**Section III** Type-approval certificate (model)

Appendix 1 - Test results for type-approval (model)

**Section IV** Type-approvals' numbering system

**Section V** Summary of type-approvals for on-board sewage treatment plant types

**Section VI** Summary of on-board sewage treatment plants manufactured (model)

**Section VII** Data sheet for on-board sewage treatment plants with type-approval (model)

**Section VIII** Test report for On-board sewage treatment plants ~~parameters record for special test~~  
(model)

~~Appendix 1 - Appendix to the on-board sewage treatment plant parameters record~~

**Section IX** Test procedure”.

b) Section VIII is worded as follows:

**Section VIII**

**Test report for On-board sewage treatment plants parameters record for special test**

(Model)

Name of vessel: \_\_\_\_\_ Unique European vessel identification number: \_\_\_\_\_

- Installation test<sup>(1)</sup>       Performance test<sup>(1)</sup>       Special test<sup>(1)</sup>

On-board sewage treatment plant manufacturer: \_\_\_\_\_  
(Make/trademark/manufacturer's trade name)

Sewage treatment plant type: \_\_\_\_\_  
(Manufacturer's designation)

Type-approval No.: \_\_\_\_\_ Year of construction of on-board sewage treatment plant: \_\_\_\_\_

Serial number: \_\_\_\_\_ Site of installation: \_\_\_\_\_

**A. Capacity of the tanks used by the on-board sewage treatment plant (incl. upstream wastewater)**

Tank name	Location of the tank within the vessel	Capacity in m <sup>3</sup>

**B. Component testing**

The following on-board sewage treatment plant parts and components were identified and checked for compliance with the manufacturer's guide to checking the components and parameters of the on-board treatment plant relevant to sewage treatment and/or the type-approval certificate.

Component	Identified component number	Conformity <sup>(1)</sup>		
		<input type="checkbox"/> Yes	<input type="checkbox"/> No	<input type="checkbox"/> n/a
		<input type="checkbox"/> Yes	<input type="checkbox"/> No	<input type="checkbox"/> n/a
		<input type="checkbox"/> Yes	<input type="checkbox"/> No	<input type="checkbox"/> n/a
		<input type="checkbox"/> Yes	<input type="checkbox"/> No	<input type="checkbox"/> n/a
		<input type="checkbox"/> Yes	<input type="checkbox"/> No	<input type="checkbox"/> n/a
		<input type="checkbox"/> Yes	<input type="checkbox"/> No	<input type="checkbox"/> n/a
		<input type="checkbox"/> Yes	<input type="checkbox"/> No	<input type="checkbox"/> n/a
		<input type="checkbox"/> Yes	<input type="checkbox"/> No	<input type="checkbox"/> n/a
		<input type="checkbox"/> Yes	<input type="checkbox"/> No	<input type="checkbox"/> n/a
		<input type="checkbox"/> Yes	<input type="checkbox"/> No	<input type="checkbox"/> n/a

**C. Results of random sample measurement**

Parameter	Value obtained	Conformity <sup>(1)</sup>	
		<input type="checkbox"/> Yes	<input type="checkbox"/> No
		<input type="checkbox"/> Yes	<input type="checkbox"/> No
		<input type="checkbox"/> Yes	<input type="checkbox"/> No
		<input type="checkbox"/> Yes	<input type="checkbox"/> No

**D. Comments:** \_\_\_\_\_  
 \_\_\_\_\_  
 \_\_\_\_\_  
 \_\_\_\_\_

Name of inspector: \_\_\_\_\_  
 Place and date: \_\_\_\_\_  
 Stamp/signature: \_\_\_\_\_

<sup>(1)</sup> Specify as appropriate.

**1. General**

**1.1 Particulars of the on-board sewage treatment plant**

1.1.1 Make: .....

1.1.2 Manufacturer's designation: .....

1.1.3 Type-approval number: .....

1.1.4 Serial number of the on-board sewage treatment plant: .....

**1.2 Documentation**

The on-board sewage treatment plant shall be tested and the test results recorded on separate sheets which shall be individually numbered, signed by the inspector and attached to this record.

**1.3 Testing**

Testing shall be carried out on the basis of the manufacturer's guide to checking the components and parameters of the on-board treatment plant relevant to sewage treatment in accordance with Article 1.01(9.10). In justified individual cases inspectors may at their own discretion dispense with checking certain plant components or parameters.

During the test at least one random sample shall be taken. The results of the random sample measurement shall be compared with the control values set out in Article 18.01(2), Table 2.

1.4 This test report, together with the attached records, comprises a total of .....<sup>11</sup>..pages.

**2. Parameters**

This is to certify that the on-board sewage treatment plant tested does not diverge to an inadmissible extent from the parameters and control values for operation specified in Article 18.01(2), Table 2 are not exceeded.

Name and address of the technical service: .....

Name of inspector: .....

Place and date: .....

Signature: .....

Test recognised by competent authority: .....

Place and date: .....

Signature: .....

Seal of the competent authority

<sup>11</sup> To include by tester

Name and address of the technical service: .....  
.....  
.....  
Name of inspector: .....  
Place and date: .....  
Signature: .....

Test recognised by competent authority: .....  
.....  
.....  
Place and date: .....  
Signature: .....

Seal of the competent authority

Name and address of the technical service: .....  
.....  
.....  
Name of inspector: .....  
Place and date: .....  
Signature: .....

Test recognised by competent authority: .....  
.....  
.....  
Place and date: .....  
Signature: .....

Seal of the competent authority

**Appendix 4**  
**Annex to the on-board sewage treatment plant parameters record**  
 (Model)

Name of vessel: \_\_\_\_\_ Unique European vessel identification number: \_\_\_\_\_

Manufacturer: \_\_\_\_\_ Plant type: \_\_\_\_\_  
(Make/trademark/manufacturer's trade name) (Manufacturer's designation)

Type-approval No.: \_\_\_\_\_ Year of construction of on-board sewage treatment plant: \_\_\_\_\_

Serial number of on-board sewage treatment plant: \_\_\_\_\_ Site of installation: \_\_\_\_\_  
(Serial number)

The on-board sewage treatment plant and its treatment-relevant components were identified from the data plate. The test was carried out on the basis of the manufacturer's guide to checking the plant components and parameters relevant to sewage treatment.

**A. Component testing**

Additional treatment-relevant components which are listed in the manufacturer's guide to checking the plant components and parameters relevant to sewage treatment or Section II Appendix 4 are to be entered here:

Component	Identified component number	Conformity <sup>12</sup>		
		<input type="checkbox"/> Yes	<input type="checkbox"/> No	<input type="checkbox"/> n/a
		<input type="checkbox"/> Yes	<input type="checkbox"/> No	<input type="checkbox"/> n/a
		<input type="checkbox"/> Yes	<input type="checkbox"/> No	<input type="checkbox"/> n/a
		<input type="checkbox"/> Yes	<input type="checkbox"/> No	<input type="checkbox"/> n/a
		<input type="checkbox"/> Yes	<input type="checkbox"/> No	<input type="checkbox"/> n/a
		<input type="checkbox"/> Yes	<input type="checkbox"/> No	<input type="checkbox"/> n/a
		<input type="checkbox"/> Yes	<input type="checkbox"/> No	<input type="checkbox"/> n/a
		<input type="checkbox"/> Yes	<input type="checkbox"/> No	<input type="checkbox"/> n/a

<sup>12</sup>—Specify as appropriate.



**B. Results of random sample measurement:**

Parameter	Value obtained	Conformity <sup>(13)</sup>	
BOD <sub>5</sub>		<input type="checkbox"/> Yes	<input type="checkbox"/> No
COD		<input type="checkbox"/> Yes	<input type="checkbox"/> No
TOC <sup>(14)</sup>		<input type="checkbox"/> Yes	<input type="checkbox"/> No

**C. Comments:**

(The following deviating settings, modifications or alterations to the installed on-board sewage treatment plant were found.)

.....  
.....  
.....  
.....  
.....

Name of inspector: .....

Place and date: .....

Signature: .....

<sup>13</sup>—Specify as appropriate.

<sup>(14)</sup>—The TOC will be monitored as of stage II of the maximum values in table 2 in Article 18.01(2).

70. Annex 8 is worded as follows:

**“ANNEX 8  
SUPPLEMENTARY PROVISIONS APPLICABLE TO CRAFT EQUIPPED  
WITH PROPULSION OR AUXILIARY SYSTEMS OPERATING  
ON FUELS WITH A FLASHPOINT EQUAL TO OR LOWER THAN 55 °C**

**Contents**

<b>Section I</b>	Definitions
<b>Section II</b>	Fuel storage
Chapter 1	LNG
Chapter 2	Methanol
Chapter 3	Hydrogen
<b>Section III</b>	Energy converters
Chapter 1	Propulsion <del>and</del> auxiliary systems with fuel cells
Chapter 2	Propulsion <del>and</del> auxiliary systems with internal combustion engines using LNG as primary fuel
Chapter 3	Propulsion <del>and</del> auxiliary systems with internal combustion engines using methanol as fuel
Chapter 4	Propulsion and auxiliary systems with internal combustion engines using hydrogen as fuel

## Section I Definitions

For the purposes of this Annex, the following definitions shall apply:

### 1.1 General

- 1.1.1 *Enclosed room*: any room within which, in the absence of forced ventilation, the ventilation will be limited, and any explosive atmosphere will not be dispersed naturally.
- 1.1.2 *Semi-enclosed room*: a room limited by decks or bulkheads in such a manner that the natural conditions of ventilation are notably different from those obtained on open deck.
- 1.1.3 *Pressure Relief Valve (PRV)*: a spring-loaded device which is activated automatically by pressure, the purpose of which is to protect the tank or piping against unacceptable excess internal pressure.
- 1.1.4 *Pressure Vacuum (P/V) valve*: a valve or set of valves which keeps the tank overpressure or underpressure within tank design limits.
- 1.1.5 *Thermally activated pressure relief device (TPRD)*: a device which is activated automatically by temperature, the purpose of which is to protect the tank or piping against unacceptable excess internal pressure.
- 1.1.6 *Controlled tank venting system*: a system fitted with P/V valves to relieve overpressure and underpressure.
- 1.1.74 *ESD*: emergency shutdown, the immediate stopping of the energy converter and of all its processes as a reaction of the control system to deviations of the process parameters in order to avoid damage to the components and craft as well as hazards to people.
- 1.1.85 *Master gas-fuel valve*: an automatic shut-off valve in gas fuel supply lines to engines (respectively fuel cells space).
- 1.1.96 *Double block and bleed valve*: a set of two automated valves in series in a pipe and a third valve enabling the pressure release from the pipe between those two valves leading to a safe location. The arrangement may also consist of a two-way valve and a closing valve instead of three separate valves.
- 1.1.107 *Air lock*: a space enclosed by gastight steel bulkheads with two gastight doors, intended to separate a non-hazardous area from a hazardous area.
- 1.1.118 *Double wall piping*: piping with a double wall design for which the space between the walls is pressurised with inert gas and equipped to detect any leakage of one of the two walls.
- 1.1.129 *Maximum working pressure*: the maximum pressure that is acceptable in a fuel tank or piping during operation. This pressure equals the opening pressure of pressure relief valves or devices.

- 1.1.13-10 *Design pressure*: the pressure on the basis of which the fuel tank or piping has been designed and built.
- 1.1.14-11 *Ventilated ducting*: a gas pipe installed in a pipe or duct equipped with mechanical exhaust ventilation.
- 1.1.15-12 *Gas warning equipment*: warning equipment to protect people and property from hazardous gases and gas-air mixtures. It consists of gas detectors to identify gases, a control unit for processing the signals and a display/alarm unit for displaying the status and warning.
- 1.1.16-13 *Secondary barrier*: the enclosure surrounding of the elements containing fuel (or the fuel cell components), designed to prevent fuel from escaping into the surrounding areas in the case of a leaking component (primary barrier).
- 1.1.17 *Lowest possible waterline*: the waterline corresponding to the displacement of the craft without ballast and without load.
- 1.1.18 *Dual-fuel engine*: an engine that is designed to simultaneously operate on two fuels, both fuels being metered separately, the consumed amount of one of the fuels relative to the other one being able to vary depending on the operation.
- 1.1.19 *Swappable tank*: a container or rack with one or several tanks, intended for temporary storage of fuel on board, supplying fuel for the propulsion or auxiliary systems of the craft and designed for being moved outboard.

## 2. Liquefied natural gas (LNG)

- 1.2.1 *Liquefied natural gas (LNG)*: natural gas that has been liquefied by cooling it to a temperature of - 161 °C.
- 1.2.2 *LNG system*: all parts components of the craft that may contain liquefied natural gas (LNG) or Natural Gas, such as engines, fuel tanks and bunkering piping.
- 1.2.3 *LNG bunkering system*: the arrangement for the bunkering of liquefied natural gas (LNG) on board (bunkering station and bunkering piping).
- 1.2.4 *Bunkering station*: the area on board where all equipment used for bunkering is located, such as manifolds, valves, survey instruments, safety equipment, monitoring station, tools, etc.
- 1.2.5 *LNG containment system*: the arrangement for the storage of liquefied natural gas (LNG) including tank connections.
- 1.2.6 *Gas supply system*: the arrangement, including the gas preparation system, gas supply lines and valves, to supply gas on board to all gas consuming equipment.

1.2.7 *Gas preparation system*: the unit used to convert liquefied natural gas (LNG) into Natural Gas, its accessories and its piping.

~~1.2.8 *Dual fuel engines*: engines using liquefied natural gas (LNG) combined with fuel with a flashpoint above 55 °C.~~

1.2.89 *System components*: all components of the installation that may contain liquefied natural gas (LNG) or Natural Gas (NG) (fuel tanks, pipelines, valves, hoses, pistons, pumps, filters, instrumentation, etc.).

### 3. Fuel cells

1.3.1 *Fuel cell system*: the system comprising the fuel cell components as well as other components and systems required to operate the fuel cells and to supply electrical power to the craft. This excludes the bunkering, storage and fuel supply systems.

1.3.2 *Fuel cell components*: all components of a fuel cell system which may contain fuel or hazardous vapours.

1.3.3 *Fuel cell space*: any enclosed space or enclosure containing a part or all fuel cell components.

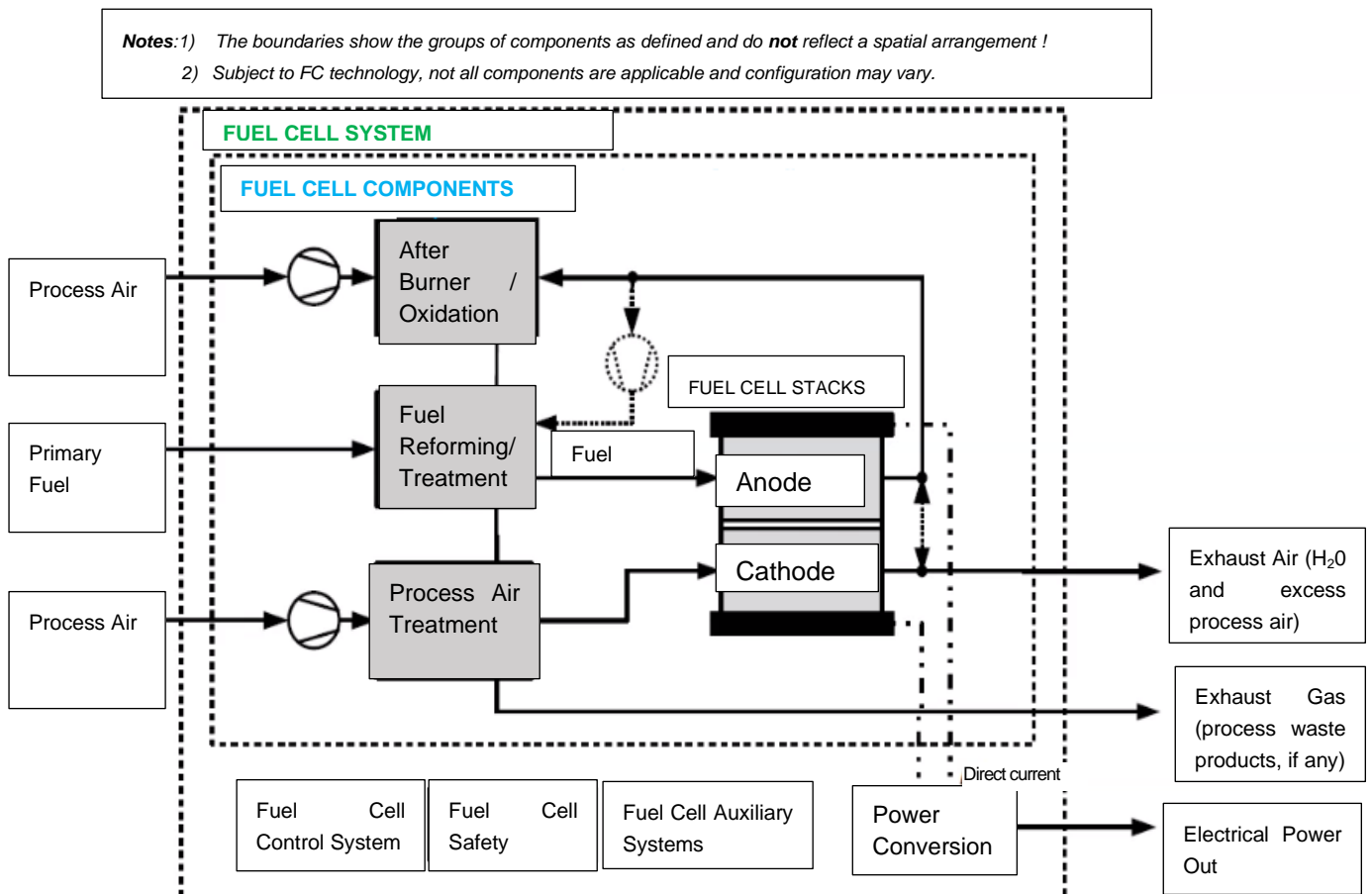

- 1.3.4 *Fuel cell*: an energy converter in which, by oxidation, the chemical energy of the fuel is directly converted to electrical and thermal energy.
- 1.3.5 *Reformer*: a device to convert gaseous or liquid primary fuels to reformat that can be used in fuel cells.
- 1.3.6 *Primary fuel*: fuel supplied to a fuel cell system.
- 1.3.7 *Fuel*: primary fuel or reformat with which the fuel cell is fed to convert energy.
- 1.3.8 *Reformat*: a hydrogen-containing gas generated in the reformer from primary fuel.
- 1.3.9 *Buffer vessel*: a device forming part of the fuel cell system to temporarily hold fuel in order to secure the stable operation of the fuel cell system, in particular to balance the flow of fuel to a fuel cell.

## **Section II Fuel Storage**

### **Chapter 1 LNG**

#### **2.1.1 LNG containment system**

- 2.1.1.1 The LNG containment system shall be separated from engine rooms or other high fire risk areas.
- 2.1.1.2 LNG fuel tanks shall be located as close as possible to the longitudinal centreline of the craft.
- 2.1.1.3 The distance between the ship's hull wall of the craft and the LNG fuel tank shall not be less than 1,00 m. If LNG fuel tanks are located:
- below deck, the craft shall have a double side and a double bottom at the location of the LNG fuel tanks. The width of the double sides and the height of the double bottom shall not be less than 0,60 m.
  - on open deck, the distance shall be at least B/5 from the vertical planes defined by the craft's sides.
- 2.1.1.4 The LNG fuel tank shall be an independent tank designed in accordance with the European Standards EN 13530-1 : 2002, EN 13530-2/AC : 2006, ISO 20421-1:2019, EN 13458-2 : 2002 in combination with dynamic loads, or the IGC-Code (type C tank). The inspection body can accept other equivalent standards of one of the Member States.
- 2.1.1.5 Tank connections shall be mounted above the highest liquid level in the tanks. The inspection body can accept connections below the highest liquid level.
- 2.1.1.6 If tank connections are below the highest liquid level of the LNG fuel tanks, drip trays shall be placed below the tanks that meet the following requirements:
- the capacity of the drip tray shall be sufficient to contain the volume which could escape in the event of a pipe connection failure;
  - the material of the drip tray shall be suitable stainless steel; and
  - the drip tray shall be sufficiently separated or insulated from the hull or deck structures, so that the hull or deck structures are not exposed to unacceptable cooling in case of leakage of LNG.
- 2.1.1.7 The LNG containment system shall be provided with a secondary barrier. No secondary barrier is required for the LNG containment systems where the probability for structural failures and leakages through the primary barrier is extremely low and can be neglected.
- 2.1.1.8 If the secondary barrier of the LNG containment system is part of the hull structure it may be a boundary of the tank room subject to necessary precautions against leakage of cryogenic liquid.
- 2.1.1.9 The location and construction of the LNG containment system and the other equipment on open deck shall assure sufficient ventilation. Accumulation of escaped NG shall be prevented.

- 2.1.1.10 If condensation and icing due to cold surfaces of LNG fuel tanks lead to safety or functional problems, appropriate preventive or remedial measures shall be taken.
- 2.1.1.11 Each LNG fuel tank is to be fitted with at least two pressure relief valves that can prevent an overpressure if one of the valves is closed off due to malfunctioning, leakage or maintenance.
- 2.1.1.12 If fuel release into the vacuum space of a vacuum insulated LNG fuel tank cannot be excluded, the vacuum space shall be protected by a suitable pressure relief valve. If LNG fuel tanks are located in enclosed or semi enclosed rooms, the pressure relief device shall be connected to a venting system.
- 2.1.1.13 The exhaust outlets of the pressure relief valves shall be located not less than 2,00 m above the deck at a distance of not less than 6,00 m from the accommodation, passenger areas and work stations, which are located outside the hold or the cargo area. This height may be reduced when within a radius of 1,00 m round the pressure relief valves outlet there is no equipment, no work is being carried out, signs indicate the area and appropriate measures to protect the deck are being taken.
- 2.1.1.14 It shall be possible to safely empty the LNG fuel tanks, even if the LNG system is shut down.
- 2.1.1.15 It shall be possible to purge gas and vent LNG fuel tanks including gas piping systems. It shall be possible to perform inerting with an inert gas (e.g. nitrogen or argon) prior to venting with dry air, to exclude an explosion hazardous atmosphere in LNG fuel tanks and gas piping.
- 2.1.1.16 LNG fuel tanks' pressure and temperature shall be maintained at all times within their design limits.
- 2.1.1.17 If the LNG system is switched off, the pressure in the LNG fuel tank, shall be maintained below the maximum working pressure of the LNG fuel tank for a period of 15 days. It shall be assumed that LNG fuel tank was filled at filling limits according to (2.1.8) and that the craft remains in idle condition.
- 2.1.1.18 LNG fuel tanks shall be electrically bonded to the craft's structure.

## **2.1.2 LNG and NG piping systems**

- 2.1.2.1 LNG and NG piping through other engine rooms or non-hazardous enclosed areas of the craft shall be enclosed in double wall piping or ventilated ducting.
- 2.1.2.2 LNG and NG piping shall not be located less than
  - a) 1,00 m from the craft's side, and
  - b) 0,60 m from the bottom.
- 2.1.2.3 All piping and all components which can be isolated with valves from the LNG system in a liquid full condition shall be provided with pressure relief valves.



- 2.1.2.4 Piping shall be electrically bonded to the craft's structure.
- 2.1.2.5 Low temperature piping shall be thermally isolated from the adjacent hull structure, where necessary. Protection against accidental contact shall be provided.
- 2.1.2.6 The design pressure of piping shall not be less than 150 % of the maximum working pressure. The maximum working pressure of piping inside rooms shall not exceed 1000 kPa. The design pressure of the outer pipe or duct of gas piping systems shall not be less than the design pressure of the inner gas pipe.
- 2.1.2.7 Gas piping in ESD protected engine rooms shall be located as far away as practicable from the electrical installations and tanks containing flammable liquids.

### **2.1.3 Drainage systems**

- 2.1.3.1 Drainage systems for areas where LNG or NG can be present shall:
  - a) be independent and separate from the drainage system of areas where LNG and NG cannot be present, and
  - b) not lead to pumps in non-hazardous areas.
- 2.1.3.2 Where the LNG containment system does not require a secondary barrier, suitable drainage arrangements for the tank rooms that are not connected to the engine rooms shall be provided. Means of detecting any LNG leakage shall be provided.
- 2.1.3.3 Where the LNG containment system requires a secondary barrier, suitable drainage arrangements for dealing with any leakage of LNG into the inter-barrier spaces shall be provided. Means of detecting such a leakage shall be provided.

### **2.1.4 Drip trays**

- 2.1.4.1 Suitable drip trays shall be fitted where leakage can cause damage to the craft's structure or where limitation of the area which is affected from a spill is necessary.

### **2.1.5 Arrangement of entrances and other openings**

- 2.1.5.1 Entrances and other openings from a non-hazardous area to a hazardous area shall only be permitted to the extent necessary for operational reasons.
- 2.1.5.2 For entrances and openings to a non-hazardous area within 6,00 m from the LNG containment system, the gas preparation system or the outlet of a pressure relief valve, a suitable airlock shall be provided.
- 2.1.5.3 Air locks shall be mechanically ventilated at an overpressure relative to the adjacent hazardous area. Doors shall be of self-closing type and shall not be fitted with holding back arrangements.

- 2.1.5.4 Air locks shall be designed in a way that no gas can be released to non-hazardous areas in case of the most critical events in the hazardous spaces separated by the air lock. The events shall be evaluated in the risk assessment according to Article 30.04.
- 2.1.5.5 Air locks shall be free of obstacles, shall provide easy passage and shall not be used for other purposes.
- 2.1.5.6 An optical and acoustic alarm shall be given on both sides of the air lock, if more than one door is not closed/moved from the closed position or if gas is detected in the air lock.

## **2.1.6 Ventilation systems**

- 2.1.6.1 The ventilators used for ventilation of hazardous spaces shall be of a certified safe type.
- 2.1.6.2 Electric motor driving ventilators shall comply with the required explosion protection in the area where it is installed.
- 2.1.6.3 An optical and acoustic alarm shall be triggered in the wheelhouse or at any other permanently manned location in the event of any loss of the required ventilating capacity.
- 2.1.6.4 Any ducting used for the ventilation of hazardous spaces shall be separate from that used for the ventilation of non-hazardous spaces.
- 2.1.6.5 Required ventilation systems required to avoid any explosive atmosphere shall have at least two ventilators with independent power supply, each of sufficient capacity, to avoid any gas accumulation.
- 2.1.6.6 Air for ventilation of hazardous spaces shall be taken from non-hazardous areas.
- 2.1.6.7 Air for ventilation of non-hazardous spaces shall be taken from non-hazardous areas which are located at least 1,50 m from the boundaries of any hazardous area.
- 2.1.6.8 Where the inlet duct passes through a hazardous space, the duct shall have overpressure relative to this space. Overpressure shall not be required if it is ensured that gases cannot leak into the duct.  
  
Where the outlet duct from a hazardous space passes through a non-hazardous room, the duct shall have underpressure relative to this space. Underpressure shall not be required when structural measures on the duct ensure that gases cannot leak into the room.
- 2.1.6.9 Air outlets from hazardous spaces shall be located in an open area which has the same or less lower risk of hazard than the ventilated space/room.
- 2.1.6.10 Air outlets from non-hazardous spaces shall be located outside any hazardous spaces.
- 2.1.6.11 In enclosed rooms the ventilation exhaust ducts shall be located at the top of these rooms. Air inlets shall be located at the bottom.

## 2.1.7 LNG bunkering system

- 2.1.7.1 The LNG bunkering system shall be arranged in such a way that
- no gas is discharged into the atmosphere during filling of LNG fuel tanks, and
  - the quantity of gas discharged while connecting, disconnecting or purging of hoses is minimised.
- 2.1.7.2 Bunkering stations and all valves used for bunkering shall be located on the open deck so that sufficient natural ventilation is provided.
- 2.1.7.3 Bunkering stations shall be so positioned and arranged in such a way that any damage to the gas piping does not cause damage to the craft's LNG containment system.
- 2.1.7.4 Suitable means shall be provided to relieve the pressure and remove liquid contents from pump suctions and bunker piping.
- 2.1.7.5 Hoses used for the bunkering of LNG shall be:
- compatible with LNG, in particular suitable for the LNG temperature, and
  - designed for a bursting pressure not less than five times the maximum pressure they can be subjected to during bunkering.
- 2.1.7.6 The bunkering manifold shall be designed to withstand normal mechanical loads during bunkering. The connections shall be of dry-disconnect type and equipped with appropriate additional safety dry break-away couplings.
- 2.1.7.7 It shall be possible to operate the master LNG bunkering valve during bunkering operations from a safe control station on the craft.
- 2.1.7.8 Bunkering piping shall be arranged for inerting and gas freeing.
- 2.1.7.9 All the components of the bunkering system shall be in accordance with European Standard EN 20519 : 2017/2022 (5.3 to 5.7).

## 2.1.8 Filling limits of LNG fuel tanks

- 2.1.8.1 The level of LNG in the LNG fuel tank shall not exceed the filling limit of 95 % full at the reference temperature. The reference temperature means the temperature corresponding to the vapour pressure of the fuel at the opening pressure of the pressure relief valves.
- 2.1.8.2 A filling limit curve for LNG filling temperatures shall be prepared from the following formula:

$$LL = FL \cdot \rho_R / \rho_L$$

where:

- $LL$  = loading limit, maximum allowable liquid volume relative to the LNG fuel tank volume to which the tank may be loaded, expressed in per cent,
- $FL$  = filling limit expressed in per cent, here 95 %,
- $\rho_R$  = relative density of fuel at the reference temperature,
- $\rho_L$  = relative density of fuel at the loading temperature.

2.1.8.3 For craft exposed to significant wave heights or significant motion on account of operations, the filling limit curve shall be adapted accordingly, based on the risk assessment, according to Article 30.04.

## 2.1.9 Gas supply system

2.1.9.1 The gas supply system shall be so arranged that the consequences of any release of gas will be minimised, while providing safe access for operation and inspection.

2.1.9.2 The parts of the gas supply systems which are located outside the engine room or the fuel cell space shall be designed in a way that a failure of one barrier cannot lead to a leak from the system into the surrounding area causing immediate danger to the people on board, the environment or the craft.

2.1.9.3 LNG fuel tank inlets and outlets shall be provided with valves located as close to the tank as possible.

2.1.9.4 The gas supply system to each engine or several engines shall be equipped with a master gas fuel valve. The valves shall be situated as close as practicable to the gas preparation system but, in any case, outside the engine room.

The gas supply system to each fuel cell space or several fuel cell spaces shall be equipped with a master gas fuel valve to shut-off fuel supply lines to consumers. The valves shall be situated as close as practicable to the gas preparation system but, in any case, outside the fuel cell space.

2.1.9.5 In the case of a propulsion and/or auxiliary system with an internal combustion engine, the master gas fuel valve shall be operable:

- a) within and outside the engine room, and
- b) from the wheelhouse.

2.1.9.6 In the case of a propulsion and/or auxiliary system with fuel cells, by analogy with Article 8.05(7), the master gas fuel valve shall be operable:

- a) from the outside in the direct vicinity of the fuel cell space,
- b) from the inside in case of fuel cell space referred to in (3.1.1.14.5), and
- c) from the wheelhouse.

2.1.9.7 Any gas consuming equipment shall be provided with a set of double block and bleed valves to assure safe isolation of the fuel supply system. The two block valves shall be of the fail-to-close type, while the ventilation valve shall be of the fail-to-open type.

- 2.1.9.8 For multi-engine installations, where a separate master gas fuel valve is provided for each engine and for one-engine installations, the master gas fuel valve and the double block and bleed valve functions can be combined.

For installations with several fuel spaces, where a separate master gas fuel valve is provided for each fuel space and for a single fuel cell, the master gas fuel valve and the double block and bleed valve functions can be combined.

One shutdown valve of the double block and bleed valves shall also be manually operated.

## **2.1.10 Gas supply shut down**

- 2.1.10.1 If the fuel gas supply is not changed over to gasoil before stopping, the gas supply system from the master gas fuel valve to the engine and the exhaust system shall be purged in order to discharge any residual gas which may be present.

- 2.1.10.2 In case of an emergency stop or a normal stop or an ESD, the supply of gas supply system shall be automatically shut off not later than

- a) the supply of the other fuel for dual fuel engines. It shall not be possible to shut off the other fuel without first or simultaneously closing the gas supply to the respective cylinders or to the complete engine.
- b) the ignition source for single fuel engines. It shall not be possible to shut off the ignition source without first or simultaneously closing the gas supply to the respective cylinders or to the complete engine.

~~2.1.10.3 In the case of a propulsion and auxiliary system with an internal combustion engine, it shall not be possible to shut off the combustion ignition source without first or simultaneously closing the gas supply to the corresponding cylinder or to the complete engine.~~

- 2.1.10.34 In the case of a propulsion and/or auxiliary system with fuel cells, it shall not be possible to shut off the fuel cell system without first or simultaneously closing the gas supply.

## **2.1.11 Fire Safety**

### **2.1.11.1 General**

- 2.1.11.1.1 In addition to Article 30.08, the provisions of (2.1.11) apply.

- 2.1.11.1.2 A room or enclosure containing the gas preparation system or parts thereof shall be regarded as an engine room for fire protection purposes.

### **2.1.11.2 Fire alarm system**

- 2.1.11.2.1 Smoke detectors alone are not sufficient for rapid detection of a fire.

- 2.1.11.2.2 The fire alarm system shall have the means to identify each fire detector or manual call point individually.

2.1.11.2.3 The gas safety system shall shut down the relevant parts of the gas supply system automatically upon fire detection in rooms containing gas installations.

### **2.1.11.3 Fire protection**

2.1.11.3.1 Accommodation, passenger areas, engine rooms and escape routes shall be shielded with Type A60 partitions, where the distance is less than 3,00 m to LNG fuel tanks and bunkering stations located on deck.

2.1.11.3.2 The boundaries of LNG fuel tank rooms and ventilation ducts to such rooms below the bulkhead deck shall comply with Type A60. However, where the room is adjacent to tanks, voids, auxiliary engine rooms of little or no fire risk, sanitary and similar spaces, the insulation may comply with Type A0.

### **2.1.11.4 Fire prevention and cooling**

2.1.11.4.1 A water spray system shall be installed for cooling and fire prevention to cover exposed parts of LNG fuel tank(s) located on open deck.

2.1.11.4.2 If the water spray system is part of the firefighting systems mentioned in Articles 13.04 or 13.05, the required fire pump capacity and working pressure shall be sufficient to ensure the operation of both the required numbers of hydrants and hoses and the water spray system simultaneously. The connection between water spray system and the firefighting systems mentioned in Articles 13.04 or 13.05 shall be provided through a screw-down non-return valve.

2.1.11.4.3 If firefighting systems mentioned in Articles 13.04 or 13.05 are installed onboard a craft where the LNG fuel tank is located on open deck, isolating valves shall be fitted in the firefighting systems in order to isolate damaged sections of the firefighting systems. Isolation of a section of firefighting systems shall not deprive the fire line ahead of the isolated section of water.

2.1.11.4.4 The water spray system shall also provide coverage for boundaries of the superstructures, unless the tank is located 3,00 m or more from the boundaries.

2.1.11.4.5 The water spray system shall be designed to cover all areas as specified above with an application rate of 10 l/min/m<sup>2</sup> for horizontal projected surfaces and 4 l/min/m<sup>2</sup> for vertical surfaces.

2.1.11.4.6 The water spray system shall be capable of being put into operation from the wheelhouse and from the deck.

2.1.11.4.7 The nozzles shall be arranged to ensure an effective distribution of water throughout the area being protected.

### **2.1.11.5 Fire extinguishing**

2.1.11.5.1 In addition to the requirements of Article 13.03, two additional portable dry powder fire extinguishers of at least 12 kg capacity shall be located near the bunkering stations. They shall be suitable for Class C fires.

## **2.1.12 Submerged gas pump motors**

2.1.12.1 Submerged gas pump motors and their supply cables may be fitted in LNG containment systems. Arrangements shall be made to alarm in low liquid level and automatically shut down the motors in the event of low-low liquid level. The automatic shutdown may be accomplished by sensing low pump discharge pressure, low motor current, or low liquid level. This shutdown shall give an optical and acoustic alarm in the wheelhouse. Gas pump motors shall be capable of being isolated from their electrical supply during gas-freeing operations.

## **2.1.13 Control, Monitoring and Safety Systems**

### **2.1.13.1 General**

2.1.13.1.1 In addition to Article 30.10, the provisions of (2.1.13) apply.

2.1.13.1.2 The gas supply system shall be fitted with its own gas control and gas monitoring system and its own gas safety system. All elements of these systems shall be capable of being functionally tested.

2.1.13.1.3 The gas safety system shall shut down the gas supply system automatically, upon failure in systems essential for the safety, and upon fault conditions which may develop too fast for manual intervention.

### **2.1.13.2 LNG bunkering system and LNG containment system monitoring**

2.1.13.2.1 Each LNG fuel tank shall be fitted with:

- a) at least two liquid level indicators, which shall be arranged so that they can be maintained in an operational condition,
- b) a pressure indicator capable of indicating throughout the operating pressure range and which is clearly marked with the maximum working pressure of the LNG fuel tank,
- c) a high liquid level alarm operating independently of other liquid level indicators which shall give an optical and acoustic alarm when activated, and
- d) an additional sensor operating independently of the high liquid level alarm which shall automatically actuate the master LNG bunkering valve in a manner that will both avoid excessive liquid pressure in the bunkering piping and prevent the tank from becoming liquid full.

2.1.13.2.2 Each pump discharge line and each liquid and vapour gas shore connection shall be provided with at least one local pressure indicator. In the pump discharge line, the indicator shall be placed between the pump and the first valve. The permissible maximum pressure or vacuum value shall be indicated on each indicator.

2.1.13.2.3 A high-pressure alarm shall be provided at the LNG containment system and at the pump. Where vacuum protection is required, a low-pressure alarm shall be provided.

2.1.13.2.4 Control of the bunkering shall be possible from a safe control station remote from the bunkering station. At this control station the LNG fuel tank pressure and level shall be monitored. Overfill alarm, high and low-pressure alarm and automatic shutdown shall be indicated at this control station.

2.1.13.2.5 If the ventilation in the ducting enclosing the bunkering lines stops, an optical and acoustic alarm shall be actuated at the control station.

2.1.13.2.6 If gas is detected in the ducting enclosing the bunkering piping an optical and acoustic alarm and emergency shutdown shall be actuated at the control station.

2.1.13.2.7 Appropriate and sufficient suitable protective clothing and equipment for bunkering operations shall be available on board according to operating manual.

### **2.1.13.3 Engine operation monitoring**

~~2.1.13.3.1 Indicators shall be fitted in the wheelhouse and the engine room for:~~

~~a) operation of the engine in case of a gas-only engine, or~~

~~b) operation and mode of operation of the engine in the case of a dual fuel engine.~~

### **2.1.13.3.4 Gas warning equipment**

2.1.13.3.4.1 Gas warning equipment shall be designed, installed and tested in accordance with a recognised Standard, such as European Standard EN 60079-29-1 : 2020.

2.1.13.3.4.2 Permanently installed gas detectors shall be fitted in provided for:

- a) tank connection areas including LNG fuel tanks, pipe connections and first valves,
- b) ducts around gas piping,
- c) engine rooms containing gas piping, gas equipment or gas consuming equipment,
- d) the room containing the gas preparation system,
- e) other enclosed rooms containing gas piping or other gas equipment without ducting,
- f) other enclosed or semi-enclosed rooms
  - aa) where gas vapours may accumulate including inter-barrier spaces and
  - bb) tank rooms of independent LNG fuel tanks other than type C,
- g) air locks, and
- h) ~~ventilation inlets to~~ air outlets of rooms in which gas vapours may accumulate.

2.1.13.3.4.3 By derogation to (2.1.13.3.4.2), permanently installed sensors which detect gas by difference of pressure can be used for inter-barrier spaces in double wall piping.

2.1.13.3.4.4 The number and redundancy of gas detectors in each room shall be considered taking size, layout and ventilation of the room into account.

2.1.13.3.4.5 Permanently installed gas detectors shall be located where gas may accumulate and in the ventilation outlets of these rooms.



2.1.13.34.6 An optical and acoustic alarm shall be activated before the gas concentration reaches 20 % of the lower explosive limit. The gas safety system shall be activated at 40 % of the lower explosive limit.

2.1.13.34.7 Optical and acoustic alarms from the gas warning equipment shall be actuated in the wheelhouse.

#### **2.1.13.45 Safety functions of gas supply systems**

2.1.13.45.1 If the gas supply system is shut off due to activation of an automatic valve, it shall not be opened/restarted until the reason for the disconnection is ascertained and the necessary actions taken. Instructions to this effect shall be placed in a prominent position at the control station for the shut-off valves in the gas supply lines.

2.1.13.45.2 If the gas supply system is shut off due to a gas leak, it shall not be opened until the leak has been found and the necessary actions have been taken. Instructions to this effect shall be placed in a prominent position in the engine room.

2.1.13.45.3 The gas supply system shall be arranged for manual remote emergency stop from the following locations as applicable:

- a) wheelhouse,
- b) control station of the bunkering station, or
- c) any permanently manned location.

## Chapter 2 Methanol

(left void)

### 2.2.1 General

2.2.1.1 Equipment or piping containing liquid methanol fuel shall be arranged in enclosures, spaces or ducts providing a secondary barrier. This requirement applies notably to pump, filters and fittings.

No secondary barrier is required on open deck.

### 2.2.2 Methanol fuel tanks

2.2.2.1 Methanol fuel shall be stored in tanks which are

- a) either an integral part of the hull or which are firmly attached to the hull;
- b) made in way that they are able to withstand the mechanical, chemical and thermal stresses to which they are likely to be subjected.

Materials other than steel may be used for methanol fuel tanks (consisting of primary barrier and where applicable secondary barrier), provided that these materials have structural and integrity properties equivalent to steel, at the end of the applicable fire exposure according to the standard one-hour fire test. These requirements are deemed fulfilled when the materials used provide Type A60 partitions.

2.2.2.2 Methanol fuel tanks and their piping shall be designed to prevent electrostatic charges. Independent fuel tanks shall be electrically bonded to the craft's structure.

2.2.2.3 Methanol fuel tanks and their piping and other accessories shall be laid out and arranged in such a way that neither fuel nor fuel vapours may accidentally reach the inside of the craft.

2.2.2.4 No methanol fuel tanks may be located ahead of the collision bulkhead or aft of the aft-peak bulkhead.

2.2.2.5 Methanol fuel tanks and their fittings shall not be located directly above engines or exhaust pipes.

2.2.2.6 Directly at tank outlets, the pipework for the supply of fuels shall be fitted with a quick-closing valve that can be operated from the deck, even when the spaces in question are closed.

If the operating device is concealed, the lid or cover shall not be lockable.

The operating device shall be marked in red. If the device is concealed it shall be marked with a symbol for the "quick-closing valve on the tank" in accordance with Figure 9 of Annex 4 with a side length of at least 10 cm.

2.2.2.7 Methanol fuel tanks shall be safeguarded against fuel spills during bunkering by means of appropriate onboard technical devices which shall be entered in item 52 of the inland navigation vessel certificate. Derogation from this requirement is acceptable if fuel is taken on from bunkering stations with their own technical devices to prevent fuel spills on board during bunkering.

2.2.2.8 A fixed piping system shall be arranged to allow safe gas freeing of each fuel tank.

### **2.2.3 Inerted methanol fuel tanks**

2.2.3.1 Inerted methanol fuel tanks shall be inerted at all times during normal operation.

2.2.3.2 The design of the inerted tank system shall eliminate the possibility of an explosive atmosphere in the fuel tank, during any part of the gas change, gas-freeing or inerting operation by using an inerting medium.

2.2.3.3 According to (2.2.1.1), if inerted methanol fuel tanks are located below deck, they shall be surrounded by a secondary barrier for leakage containment and detection. However, the secondary barrier can be omitted on those surfaces bound by

- a) shell plating,
- b) tank tops which are not under the static pressure of the liquid and facing open deck,
- c) tank tops which are not under the static pressure of the liquid and facing spaces permanently ventilated with at least 15 air changes per hour (e.g. engine rooms, pump rooms or similar), or
- d) other methanol fuel tanks or spaces with equipment containing methanol fuel.

2.2.3.4 For inerted methanol fuel tanks below deck,

- a) the distance between the craft's side (shell plating) and the secondary barrier of the tank shall be at least 0,60 m and
- b) the distance between the craft's bottom (shell plating) and the secondary barrier of the tank shall be at least 0,50 m.

For the case referred to in (2.2.3.3)(a), this means:

- a) the distance between the craft's side (shell plating) and the vertical part of the secondary barrier of the tank opposite to the craft's side, shall be at least 0,60 m.
- b) the distance between the craft's bottom (shell plating) and the horizontal part of the upper secondary barrier of the tank, opposite to the craft's bottom, shall be at least 0,50 m.

Because the boundaries of the spaces referred to in (2.2.3.3)(c) and (d) act as secondary barrier,

- a) the distance between the craft's side (shell plating) and the boundaries of these spaces shall be at least 0,60 m and
- b) the distance between the craft's bottom (shell plating) and the boundaries of these spaces shall be at least 0,50 m.

In accordance with the risk assessment referred to in Article 30.04, the inspection body might require greater values for the distances mentioned above.

2.2.3.5 For inerted methanol fuel tanks on open deck, the distance between the vertical planes defined by the craft's sides (shell plating) and the tank shall be at least 0,60 m.

## 2.2.4 Non-inerted methanol fuel tanks

2.2.4.1 In accordance with (2.2.1.1), if non-inerted methanol fuel tanks are located below deck, they shall be surrounded by a secondary barrier for leakage containment and detection. However, the secondary barrier can be omitted on those surfaces bound by

- a) shell plating below the lowest possible waterline, or
- b) other methanol fuel tanks or spaces with equipment containing methanol fuel.

2.2.4.2 For non-inerted methanol fuel tanks below deck,

- a) the distance between the craft's side (shell plating) and the secondary barrier of the tank shall be at least 0,60 m and
- b) the distance between the craft's bottom (shell plating) and the secondary barrier of the tank shall be at least 0,50 m.

For the case referred to in (2.2.4.1)(a), this means:

- a) the distance between the craft's side (shell plating) and the vertical part of the secondary barrier of the tank opposite to the craft's side, shall be at least 0,60 m.
- b) the distance between the craft's bottom (shell plating) and the horizontal part of the upper secondary barrier of the tank, opposite to the craft's bottom, shall be at least 0,50 m.
- c) the distance between the craft's side (shell plating) and the tank, above the lowest possible waterline, shall be at least 0,60 m.

Because the boundaries of the spaces referred to in (2.2.4.1)(b) act as secondary barrier,

- a) the distance between the craft's side (shell plating) and the boundaries of these spaces shall be at least 0,60 m and
- b) the distance between the craft's bottom (shell plating) and the boundaries of these spaces shall be at least 0,50 m.

In accordance with the risk assessment referred to in Article 30.04, the inspection body might require greater values for the distances mentioned above.

2.2.4.3 For non-inerted methanol fuel tanks on open deck, the distance between the vertical planes defined by the craft's sides (shell plating) and the tank shall be at least 0,60 m.

## 2.2.5 Tank venting systems

2.2.5.1 Tank venting systems for fuel vapours shall be designed and arranged in such a way that releases are safely led overboard and do not lead to an unsafe situation.

Vent lines shall be designed and arranged in such a way that neither fuel nor fuel vapours may accidentally reach the inside of the craft.

2.2.5.2 Design and arrangement of tank venting systems shall prevent flame propagation into the fuel containment system. Each tank shall be protected by a suitable flame arrestor. Where the venting lines cannot withstand the deflagration, pressure flame screens shall be fitted to the overboard outlet.

2.2.5.3 Tank venting systems shall be sized to permit bunkering at nominal loading rate without overpressurizing the fuel tanks.

2.2.5.4 The tank vent outlets shall be arranged in such a way that no water ingress is possible.

2.2.5.5 In the tank vent lines, no shut-off valves shall be installed. For tank segregation purposes during maintenance work, shut-off valves in common vent lines may be accepted if a secondary independent overpressure or underpressure protection is provided for all connected tanks.

2.2.5.6 If a controlled tank venting system is provided for the fuel tanks:

- a) Pressure Vacuum (P/V) valves (combined or separate valves) shall be fitted to each fuel tank. The controlled tank venting system may be designed with individual vent outlets from each fuel tank or with vent lines from each individual fuel tank connected to a common header; and
- b) The controlled tank venting system shall be designed with redundancy for the relief of full flow overpressure and/or underpressure. As alternative to this redundancy, the inspection body may accept pressure sensors fitted in each fuel tank and connected to an alarm system.

2.2.5.7 The vent lines below deck shall be either:

- a) located at least 0,60 m from the craft's side (shell plating); or
- b) surrounded by a secondary barrier. The distance between the craft's side (shell plating) and the vertical part of the secondary barrier of the vent line opposite to the craft's side shall be at least 0,60 m.

If vent lines pass through accommodations, only double wall piping is allowed.

## **2.2.6 Methanol fuel piping systems**

2.2.6.1 Methanol fuel piping shall be electrically bonded to the craft's structure.

2.2.6.2 Methanol fuel piping and other accessories shall be laid out and arranged in such a way that neither fuel nor fuel vapours may accidentally reach the inside of the craft.

2.2.6.3 In accordance with (2.2.1.1), below deck, methanol fuel piping shall be surrounded by a secondary barrier for leakage containment and detection.

2.2.6.4 The horizontal distance between the secondary barrier of methanol fuel piping below deck and the craft's side (shell plating) shall be at least 0,60 m.

In accordance with the risk assessment referred to in Article 30.04, the inspection body might require greater values for the distance mentioned above.

2.2.6.5 The design pressure of the secondary barrier around a fuel pipe shall not be less than the maximum working pressure of the fuel pipe. As an alternative the secondary barrier around a fuel pipe shall be dimensioned in accordance with the calculated maximum built-up pressure in the case of a pipe rupture.

2.2.6.6 In accordance with (2.2.1.1), on open deck, a secondary barrier is not required, however:

- a) single walled methanol fuel piping shall be located as far away as practicable from the electrical installations, sources of ignition, and tanks containing flammable liquids;
- b) the number of connections of fuel pipes shall be kept to a minimum; and
- c) where necessary, connections of fuel pipes shall be screened or otherwise suitably protected to avoid fuel spray or leakages onto hot surfaces, into machinery air intakes, or other sources of ignition.

2.2.6.7 All pumps in the fuel system shall be protected against running dry (i.e. protected against operation in the absence of fuel or service fluid).

All pumps which are capable of developing a pressure exceeding the design pressure of the system shall be provided with pressure relief valves. Each pressure relief valve shall be in closed circuit, i.e. arranged to discharge back to the piping upstream of the suction side of the pump.

2.2.6.8 The design pressure for any section of the fuel piping system is the maximum gauge pressure to which the system may be subjected in service, taking into account the highest set pressure on any relief valve on the system.

2.2.6.9 For maintenance, it shall be possible that all sections of the fuel system can be safely

- a) isolated, and
- b) drained and purged of fuel.

## **2.2.7 Drainage systems and drip trays**

2.2.7.1 Suitable drainage and purging arrangements shall be provided for dealing with any leakage of methanol fuel into the interbarrier spaces.

2.2.7.2 Drainage systems for areas where methanol fuel can be present shall be independent and separate from the drainage system of areas where methanol fuel cannot be present.

2.2.7.3 For the purpose of draining methanol leakages from interbarrier spaces, provisions shall be made such that the leakages can be drained into suitable mobile or fixed collecting tanks or be lead directly overboard below the lowest possible waterline.

2.2.7.4 Leakage on open deck from single walled tanks or fuel containing equipment shall be contained and drained by a dedicated drain discharging below the lowest possible waterline.

## **2.2.8 Arrangement of entrances and other openings**

2.2.8.1 Access to a hazardous space shall not be possible before

- a) the fuel components and piping inside are safely shut down, and
- b) the inside atmosphere is confirmed gas-free by the means of sensors.

All controls and all parameters required for safe operation of the fuel system and gas freeing of the space shall be remotely operated and monitored from outside the hazardous space.

2.2.8.2 Doors or hatches to hazardous spaces shall bear on the outside the symbol corresponding to Figure 1 in Annex 4 ("No entry for unauthorised persons") as well as the fuel specific symbol in accordance with Article 30.06.

2.2.8.3 The inspection body may allow derogation to (2.2.8.1), provided that

- a) the opening of the space leads directly to open deck;
- b) the opening of the space is through an air lock;
- c) the space is considered as non-hazardous in accordance with Article 10.04; or
- d) the entering of the space does not lead to extending any zone to where a source of ignition is present.

Before allowing a derogation according to d), a classification and evaluation of areas at risk of explosion in accordance with Article 10.04 shall be conducted with accesses opened. Non-hazardous spaces to which a hazardous area could extend while accessing the hazardous space shall be appropriately marked.

2.2.8.4 Air locks shall be mechanically ventilated at an overpressure relative to the adjacent hazardous space. Doors shall be of self-closing type and shall not be fitted with holding back arrangements.

2.2.8.5 Air locks shall be designed in a way that no gas can be released to non-hazardous spaces in case of the most critical events in the hazardous spaces separated by the air lock. The events shall be evaluated in the risk assessment according to Article 30.04.

2.2.8.6 Air locks shall be free of obstacles, shall provide easy passage and shall not be used for other purposes.

2.2.8.7 An optical and acoustic alarm shall be given on both sides of the air lock, if more than one door is not closed or if gas is detected in the air lock.

## **2.2.9 Ventilation systems**

2.2.9.1 Any ducting used for the ventilation of hazardous spaces shall be separate from that used for the ventilation of non-hazardous spaces.

2.2.9.2 The ventilators used for ventilation of hazardous spaces shall be of a certified safe type.

2.2.9.3 Electric motor driving ventilators shall comply with the required explosion protection in the area where it is installed.

- 2.2.9.4 An optical and acoustic alarm shall be triggered in the wheelhouse or at any other permanently manned location in the event of any loss of the required ventilating capacity.
- 2.2.9.5 Ventilation systems required to avoid any explosive atmosphere shall have at least two ventilators with independent power supply, each of sufficient capacity. This requirement does not apply for ventilation of spaces that do not require continuous ventilation.
- 2.2.9.6 It shall be possible to safely ventilate overboard the spaces where methanol fuel may accumulate to ensure a safe atmosphere when entering the spaces is necessary.
- 2.2.9.7 Air for ventilation of hazardous spaces shall be taken from non-hazardous areas.
- 2.2.9.8 Air for ventilation of non-hazardous spaces shall be taken from non-hazardous areas which are located at least 1,50 m from the boundaries of any hazardous area.
- 2.2.9.9 Where the outlet duct from a hazardous space passes through a non-hazardous space, the duct shall have underpressure relative to this space. Underpressure shall not be required when structural measures on the duct ensure that gases cannot leak into the room.
- 2.2.9.10 Where an inlet duct passes through a hazardous space, the duct shall have overpressure relative to this space. Overpressure shall not be required if it is ensured that gases cannot leak into the duct.
- 2.2.9.11 Air outlets from hazardous spaces shall be located in an open area which has the same or less hazard than the ventilated space.
- 2.2.9.12 Air outlets from non-hazardous spaces shall be located outside any hazardous area.

#### **2.2.10 Methanol bunkering system**

- 2.2.10.1 Bunkering stations shall be located on open deck so that sufficient natural ventilation is provided. However, the inspection body may accept enclosed or semi-enclosed bunkering stations subject to special consideration with respect to provisions for mechanical ventilation.
- 2.2.10.2 Bunkering stations shall be so positioned and arranged that any damage to the methanol fuel piping does not cause damage to the craft's methanol tank system.
- 2.2.10.3 Suitable means shall be provided to relieve the pressure and remove liquid contents from bunker piping.
- 2.2.10.4 Each fuel tank filler neck shall be designed to withstand the mechanical loads during bunkering.
- 2.2.10.5 The coupling of the bunkering system shall be in accordance with European Standard EN 14420-6 : 2013.

The need for a safety dry break-away coupling shall be considered in the risk assessment in accordance with Article 30.04.



## **2.2.11 Methanol fuel supply system**

2.2.11.1 The methanol fuel supply system to each room or space with consumers shall be equipped with a remotely controlled master fuel valve to shut-off fuel supply lines to consumers. The master fuel valve shall be situated outside the room or space where the consumers are located. For tanks serving only one room or space, the master fuel valve may be combined with the quick closing tank valve.

2.2.11.2 The master fuel valve shall be operable

- a) within and outside the engine room (if present),
- b) from the inside and outside of the fuel cell space (if present), and
- c) from the wheelhouse.

2.2.11.3 The arrangement of the methanol fuel supply system shall ensure safe isolation during maintenance work.

## **2.2.12 Fire Safety**

2.2.12.1 In addition to Article 30.08, the following provisions apply.

2.2.12.2 Spaces, where equipment containing fuel is installed and where a fire hazard cannot be excluded, shall comply with the fire protection requirements for engine rooms. These requirements are deemed fulfilled when:

- a) walls, ceilings, doors and hatches of this space is made of steel or another equivalent non-combustible material;
- b) insulation material used in this space is protected against the intrusion of fuel and fuel vapours;
- c) all openings in walls, ceilings, doors and hatches of this space can be closed from outside the space. The locking devices shall be made from steel or an equivalent non-combustible material; and
- d) this space is equipped with a permanently installed firefighting system in accordance with Articles 13.05 or 13.06.

The firefighting system referred to in (d) is not required in small enclosed spaces which do not contain source of ignition.

Continuously operated electric motors, even if certified as safe according to Article 1.01(3.24), shall be considered a source of ignition, unless they are protected against overheating.

2.2.12.3 Suitable fire detectors shall be selected based on the characteristics of the fuel. Smoke detectors shall be used only in combination with other detectors which can more effectively detect methanol fires.

2.2.12.4 The fire detection system shall have the means to identify each detector individually.

2.2.12.5 At least one portable fire extinguisher in accordance with Article 13.03(2) shall be available on deck no more than 10 m walking distance away from each bunkering stations.

## **2.2.13 Control, Monitoring and Safety Systems**

### **2.2.13.1 General**

2.2.13.1.1 In addition to Article 30.10, the following provisions apply.

2.2.13.1.2 Without prejudice to Article 30.07, upon failure in systems essential for the safety and upon fault conditions which may develop too fast for manual intervention, the methanol fuel safety system shall shut down the fuel supply system automatically.

2.2.13.1.3 The safety functions shall be arranged in a dedicated fuel safety system that is independent of the fuel control system.

2.2.13.1.4 Instrumentation devices shall be fitted to allow a local and a remote reading of essential parameters, where they are necessary to ensure a safe operation of the whole methanol fuel system including the bunkering system.

2.2.13.1.5 It shall be possible to manually shut down the methanol fuel supply system from the wheelhouse or a permanently manned location as applicable.

### **2.2.13.2 Methanol fuel tank and bunkering system**

2.2.13.2.1 Each methanol fuel tank shall be fitted with:

- a) at least one closed level gauging device, which must be positioned close to the tank in such a way that the level reading is always obtainable;
- b) an independent sensor (high-high level) triggering an optical and acoustic alarm and allowing to automatically stop the bunkering at 95 % full; and
- c) an optical and acoustic high-level alarm. This shall be able to be functionally tested from the outside of the tank and can be common with the alarm of the level gauging device according to (a), configured as an alarm on the gauging transmitter, but shall be independent of the high-high level alarm according to (b).

2.2.13.2.2 A ship-shore link shall be fitted for automatic and manual transmission of the bunkering stop order to the bunkering source.

At least the signal of the high-high level sensor shall be transmitted to the bunkering station by means of a watertight connection plug meeting the requirements of International Standard IEC 60309-1 : 2021 for 40 to 50 V DC, housing colour white, earthing contact position ten o'clock.

2.2.13.2.3 Provisions shall be made that the bunkering can be supervised and stopped at any time. Overfill alarm and automatic shutdown shall be indicated.

2.2.13.2.4 If a leakage into the interbarrier space of the bunkering line is detected, an optical and acoustic alarm and automatic shutdown of the bunkering shall be initiated.

2.2.13.2.5 Each shore connection for liquids and vapours shall be provided with at least one local pressure indicator. The permissible maximum pressure or vacuum value shall be indicated on each indicator.

2.2.13.2.6 For inerted tanks, means shall be provided that the tanks cannot be overpressurised by the inert gas system.

### **2.2.13.3 Gas and leakage warning equipment**

2.2.13.3.1 Spaces where methanol fuel vapours may accumulate shall be equipped with permanently installed means of fuel leakage detection.

The number, type and redundancy of detectors in each space shall correspond to the size, layout and ventilation of the space.

The effectiveness of leakage detection shall be demonstrated. For gas detectors, this is deemed fulfilled when a gas dispersal analysis or a physical smoke test is used to find the best arrangement.

2.2.13.3.2 Permanently installed gas detection shall be provided for:

- a) enclosed or semi-enclosed rooms,
  - aa) where fuel vapours may accumulate, and
  - bb) which contain a source of ignition.
- b) air locks, and
- c) air outlets of ventilated spaces where a fuel leakage could remain undetected in the space.

2.2.13.3.3 Gas warning equipment shall be designed, installed and tested in accordance with a Standard recognized by one of the Member States, such as European Standard EN 60079-29-1 : 2020.

2.2.13.3.4 In the event of a fuel vapour concentration above 20 % of the lower explosion limit (LEL), an optical and acoustic alarm shall be triggered in the wheelhouse or at any other permanently manned location.

The automatic shutdown required by (2.2.13.1.2) shall be activated at the latest at a fuel vapour concentration of 40 % of the lower explosion limit (LEL).

### **2.2.13.4 Provisions on safety functions of fuel supply systems**

2.2.13.4.1 The safety system shall be manually reset before the propulsion or auxiliary system can be restarted.

**Chapter 3**  
**Hydrogen**

(left void)

## **Section III** **Energy converters**

### **Chapter 1** **Propulsion and auxiliary systems with fuel cells**

#### **3.1.1 Fuel cell spaces**

3.1.1.1 The requirements of this Chapter shall apply to fuel cell spaces located either on deck or below deck.

3.1.1.2 Only components necessary for the operation of the fuel cell systems shall be permitted in fuel cell spaces.

3.1.1.3 Fuel cell components shall be surrounded by a secondary barrier. The boundary of a fuel cell space may act as a secondary barrier.

3.1.1.4 Fuel cell spaces shall be designed in such a way that their geometrical form ensures good air circulation or good distribution of inert gas, as to minimise the possibility of entrapping explosive mixture.

3.1.1.5 A permanently installed, continuously measuring gas detection system shall be in place in fuel cell spaces.

3.1.1.6 Fuel cell spaces containing fuel reformers shall also comply with the requirements for the relevant fuel storage in accordance with Annex 8, Section II.

3.1.1.7 Appropriate fire partition requirements of fuel cell spaces shall be established by the risk assessment in accordance with Article 30.04, with special consideration given to the installation location and fire load of the fuel cell space.

3.1.1.8 Fuel cell spaces shall not be located less than:

- a) 1,00 m or B/5 from the craft's side whichever is less, and
- b) 0,60 m from the craft's bottom.

The inspection body may allow shorter distances in the absence of hazardous areas, based on the risk assessment, according to Article 30.04.

3.1.1.9 One of the following concepts shall be applied to fuel cell spaces:

- a) inerted fuel cell space,
- b) explosion-protected fuel cell space, or
- c) ventilated fuel cell space.

### **3.1.1.10 Requirements for inerted fuel cell spaces**

- 3.1.1.10.1 Inerted fuel cell spaces are fuel cell spaces protected by inert gas. They shall be considered as non-hazardous areas.
- 3.1.1.10.2 The boundary of the fuel cell space that acts as secondary barrier shall be gastight. The design pressure of the boundary shall be suitable for the intended application.
- 3.1.1.10.3 During normal operation of the fuel cell system, the fuel cell space shall be inerted.
- 3.1.1.10.4 In the event of leakage of gas being detected or loss of inertion:
- a) the fuel supply to the fuel cell space concerned, and
  - b) the fuel cell components in the fuel cell space concerned shall be shut down automatically.
- 3.1.1.10.5 Gas tightness and integrity of the secondary barrier shall be permanently monitored by appropriate measures. In the event of leakage of inerted gas being detected in adjacent rooms where persons are present during normal operation, an optical and acoustic alarm shall be triggered
- a) in the affected rooms and
  - b) in the wheelhouse or at any other permanently manned location.
- In the event of failure of the gas tightness and integrity of the secondary barrier, the fuel supply to the fuel cell system shall be shut down automatically.

### **3.1.1.11 Requirements for explosion-protected fuel cell spaces**

- 3.1.1.11.1 Explosion-protected fuel cell spaces shall be considered as hazardous areas (Zone 1).
- 3.1.1.11.2 In accordance with Article 10.04, only explosion-protected equipment (certified safety) is permitted. This shall be deemed to be fulfilled if the equipment meets the relevant provisions of the European Standard series EN 60079.
- 3.1.1.11.3 By way of derogation from (3.1.1.3), the function of the secondary barrier shall be achieved by mechanical ventilation ensuring permanent negative pressure relative to adjacent rooms.
- 3.1.1.11.4 The ventilation system shall:
- a) guarantee a sufficient capacity of ventilation to ensure that the gross volume of air inside the fuel cell space is changed at least 30 times per hour, and
  - b) be independent of all other ventilation systems of the craft.
- 3.1.1.11.5 In the event of leakage of gas leading to a concentration above 20 % of the lower explosive limit (LEL), an optical and acoustic alarm shall be triggered in the wheelhouse or at any other permanently manned location.

- 3.1.1.11.6 In the event of leakage of gas leading to a concentration above 40 % of the LEL or the ventilation system fails,
- a) the fuel supply to the fuel cell space concerned, and
  - b) the fuel cell components in the fuel cell space concerned
- shall be shut down automatically.

### **3.1.1.12 Requirements for ventilated fuel cell spaces**

3.1.1.12.1 The possible hazardous areas within the ventilated fuel cell spaces shall be classified in accordance with Article 10.04.

3.1.1.12.2 In accordance with Article 10.04, only equipment suitable for the hazardous areas as classified in (3.1.1.12.1) is permitted. This shall be deemed to be fulfilled if the equipment meets the relevant provisions of the European Standard series EN 60079.

3.1.1.12.3 By way of derogation from (3.1.1.3), the function of the secondary barrier shall be achieved by mechanical ventilation ensuring permanent negative pressure relative to adjacent rooms.

3.1.1.12.4 The ventilation system shall:

- a) guarantee a sufficient capacity of ventilation to ensure that the gross volume of air inside the fuel cell space is changed at least at the rate which has been assumed for the hazardous area calculation referred to in (3.1.1.12.1). This shall be deemed to be fulfilled if the dilution is determined in accordance with Article 10.04(1), and
- b) be independent of all other ventilation systems of the craft.

3.1.1.12.5 In the event of leakage of gas leading to a concentration above 20 % of the LEL, an optical and acoustic alarm shall be triggered in the wheelhouse or at any other permanently manned location.

3.1.1.12.6 In the event of leakage of gas leading to a concentration above 40 % of the LEL or the ventilation system fails:

- a) the fuel supply to the fuel cell space concerned and
  - b) the fuel cell components in the fuel cell space concerned
- shall be shut down automatically.

### **3.1.1.13 Specific requirements or derogations for fuel cell spaces on deck**

3.1.1.13.1 For fuel cell spaces on deck, the inspection body may allow derogation from (3.1.1.3) and (3.1.1.12.3) provided that:

- a) the fuel cell space is located on open deck with no directly adjacent rooms on the same deck;
- b) the fuel cell space is naturally ventilated to ensure that the gross volume of air inside the fuel cell space is changed in accordance with (3.1.1.12.4);
- c) the risk assessment according to Article 30.04 does not identify any contraindication.

### **3.1.1.14 Access to fuel cell spaces**

3.1.1.14.1 Access to fuel cell spaces shall not be possible before the fuel cell components inside are safely shut down, isolated from the fuel supply system, drained of leakages and the inside atmosphere is confirmed gas-free.

It shall be possible to remotely operate and monitor from outside the fuel cell space all controls and all parameters required for safe operation of the fuel cell system and gas freeing of the fuel cell space.

3.1.1.14.2 The fuel cell space openings shall be equipped with an interlock preventing operation of the fuel cell system when the fuel cell space is open.

3.1.1.14.3 Doors to fuel cell spaces shall bear on the outside the symbol corresponding to Figure 1 in Annex 4 (“No entry for unauthorised persons”) as well as the fuel specific symbol in accordance with Article 30.06.

3.1.1.14.4 For the purpose of entering the inerted fuel cell spaces, it shall be possible that the inerted atmosphere in the fuel cell space is replaced by air that is safe to breathe. It shall be indicated outside the fuel cell space whether the air is safe to breathe.

3.1.1.14.5 The inspection body may allow derogation to (3.1.1.14.1), provided that:

- a) the opening of the fuel cell space leads directly to open deck,
- b) the opening of the fuel cell space is through an air lock, or
- c) the fuel cell space is considered as non-hazardous in accordance with (3.1.1.12.1).

3.1.1.14.6 For safe maintenance, it shall be possible that the fuel cell components are:

- a) isolated from the fuel supply system, and
- b) drained and purged of fuel.

3.1.1.14.7 Fuel cell systems and their components shall be installed and fitted in such a way as to be adequately accessible for operation and maintenance and shall not endanger the persons assigned to those tasks.

### **3.1.2 Fuel Piping systems in the fuel cell spaces**

3.1.2.1 The piping used for the supply of primary fuel shall comply with the respective requirements of Annex 8 Section II.

3.1.2.2 Fuel piping shall be protected against hazards arising from electrostatic charges.

3.1.2.3 The maximum working pressure for piping inside fuel cell spaces shall not exceed 1000 kPa (gauge value). The inspection body may allow higher working pressure, based on the risk assessment according to Article 30.04.



### **3.1.3 Reformer**

- 3.1.3.1 The volume of fuel in the reformer shall be limited to the volume required for a stable continuous operation. Storage of fuel in the reformer shall not be permitted.
- 3.1.3.2 Reformer with a design pressure of more than 50 kPa shall comply with the requirements of Article 8.01(2).
- 3.1.3.3 Unintended accumulations of inflammable mixtures in burner systems and oxidation units of the reformer shall be avoided.
- 3.1.3.4 An automatic burner control system shall be installed to enable the safe start, operation and shutdown of the burner system of the reformer.
- 3.1.3.5 The complete combustion of the gases in the burner shall be monitored.
- 3.1.3.6 Surfaces likely to reach high temperatures shall be provided with insulation or protection against contact.

### **3.1.4 Buffer vessel**

- 3.1.4.1 Fuel buffer vessels in fuel cell systems, if present, may only be used to provide process-related fuel and temporary reserves but not as an additional fuel storage.
- 3.1.4.2 The buffer vessels shall be arranged near the fuel cells and shall comply with the requirements of (3.1.2).

### **3.1.5 Fuel cell systems**

- 3.1.5.1 Fuel cell systems shall be constructed and tested in accordance with the applicable standards of the International Standards series IEC 62282 or equivalent standards.
- 3.1.5.2 Materials used for the fuel cell systems shall be suitable for the intended application. This shall be deemed to be fulfilled when the materials comply with:
  - a) the International Standard IEC 62282-3-100 : 2019 or
  - b) an equivalent regulation or Standard recognised by one of the Member States.

### **3.1.6 Ventilation systems**

- 3.1.6.1 The ventilators used for ventilation of hazardous areas shall be of a certified safe type.
- 3.1.6.2 Electric motor driving ventilators shall comply with the required explosion protection in the area where it is installed.
- 3.1.6.3 An optical and acoustic alarm shall be triggered in the wheelhouse or at any other permanently manned location in the event of any loss of the required ventilating capacity.

- 3.1.6.4 At least two ventilators shall be installed for the ventilation of hazardous areas to guarantee 100 % of the required ventilation capacity if one ventilator fails. The supply from the emergency power source shall also enable the ventilation system to provide 100% of the required ventilation capacity.
- 3.1.6.5 Air for ventilation of hazardous spaces shall be taken from non-hazardous areas.
- 3.1.6.6 The air for ventilation of intake from non-hazardous areas shall be located taken from non-hazardous areas which are located at least 1,50 m away from the boundaries of any hazardous area.
- 3.1.6.7 Where the inlet duct passes through a hazardous room, the duct shall have overpressure relative to this room. Overpressure shall not be required if it is ensured that gases will not cannot leak into the duct.
- 3.1.6.8 Air outlets from hazardous areas shall be located in an open area which has the same or less lower risk of hazard than the ventilated room.
- 3.1.6.9 Air outlets from non-hazardous areas shall be located outside any hazardous areas.
- 3.1.6.10 Air inlets and outlets shall be located in appropriate positions, taking into account the characteristics of the fuel used.

### **3.1.7 Exhaust systems**

- 3.1.7.1 The following provisions apply to systems for exhaust air and exhaust gas from fuel cell systems.
- 3.1.7.2 The exhaust systems of the fuel cell systems shall
- a) not be connected to the exhaust pipes of systems other than fuel cell systems and
  - b) shall lead the gases to open air.
- However, the exhaust pipes of the fuel cell systems may be combined with the fuel cell space ventilation at the ventilation outlet of the fuel cell space, provided that the exhaust gases of one fuel cell system cannot escape into another fuel cell system.
- 3.1.7.3 The exhaust systems shall be made of an appropriate material regarding its temperature limit, fire resistance, material strength and resistance to the action of condensate.
- 3.1.7.4 All suitable measures shall be taken to avoid ingress of exhaust air and exhaust gas into the various compartments of the craft.
- 3.1.7.5 Outlets of exhaust systems shall be designed in such a way that they cause no immediate danger to the people on board. They shall be located in appropriate positions, taking into account the characteristics of the exhaust air and exhaust gas.
- 3.1.7.6 The exhaust systems and their outlets are to be classified in accordance with Article 10.04. Only equipment suitable for the hazardous area as classified is permitted.

- 3.1.7.7 The exhaust systems shall be configured to keep accumulation of unoxidized gaseous fuel as low as possible.
- 3.1.7.8 Routing and isolation of the exhaust system shall take the accumulation of condensate into account.
- 3.1.7.9 Exhaust gas systems must allow safe condensate drainage.
- 3.1.7.10 If the exhaust systems are not provided by the fuel cell manufacturer, they must comply with the fuel cell manufacturer's instructions.

### **3.1.8 Purging system**

- 3.1.8.1 For fuel cell systems requiring purging for safe operation, especially before the start-up or after the shutdown of the fuel cell system, a suitable purging system that uses a medium specified by the fuel cell manufacturer shall be used.

### **3.1.9 Control, monitoring and safety systems**

- 3.1.9.1 In addition to Article 30.10, the provisions of (3.1.9) apply.
- 3.1.9.2 Each fuel cell system shall be fitted with its own control and monitoring system and its own safety system. The safety system shall be designed to operate independently of the control and monitoring system. All elements of these systems shall be capable of being functionally tested.  
  
Software for programmable electronic systems shall be developed in accordance with an acceptable quality management system considering all software lifecycle activities as design, development, supply and maintenance.
- 3.1.9.3 Sensors for the safety system shall be first routed to safety system and particular information may be also routed towards control and monitoring systems. Alarm sensors shall be directly routed to the monitoring system.
- 3.1.9.4 It shall be possible to manually shut down the fuel cell system from the following locations:
  - a) wheelhouse,
  - b) from the outside in the direct vicinity of the fuel cell space,
  - c) any permanently manned location.

The safety system shall be manually reset before the propulsion or auxiliary system can be restarted.

- 3.1.9.5 Suitable devices shall monitor chemical reactions in the reformer and in the fuel cells by means of temperature, pressure and voltage control.

## Chapter 2

### Propulsion ~~and~~ auxiliary systems with internal combustion engines using LNG as fuel

#### 3.2.1 General

3.2.1.1 Requirements of Annex 8, Section II, 2.1.2 to 2.1.6, 2.1.9, 2.1.10, 2.1.11.1, 2.1.11.2, 2.1.13.1, ~~2.1.13.3~~, 2.1.13.34 and 2.1.13.45 also apply to propulsion ~~and~~ auxiliary systems with internal combustion engines using LNG as fuel.

3.2.1.2 One of the following concepts shall be applied to ~~For~~ engine rooms ~~one of the following concepts shall be applied:~~

- a) gas safe engine room,
- b) explosion safe engine room or
- c) ESD protected engine room.

#### 3.2.2 Requirements for gas safe engine rooms

3.2.2.1 Gas safe engine rooms shall be gas safe under all conditions ("inherently gas safe"). A single failure within the LNG system shall not lead to a leakage of gas into the engine room. All gas piping within engine room boundaries shall be enclosed in a gas tight enclosure, e.g. double wall piping or ventilated ducting.

3.2.2.2 In case one barrier fails, the gas supply to the relevant part of the LNG system shall be shut down automatically.

3.2.2.3 In addition to the provision of (2.1.6), ~~t~~he ventilation system of ventilated ducting shall:

- a) guarantee a sufficient capacity to ensure that the gross volume of air inside the ventilated ducting can be changed at least 30 times per hour;
- b) be equipped to detect gas presence continuously in the space between inner and outer pipes; and
- c) be independent of all other ventilation systems, in particular the ventilation system of the engine room.

3.2.2.4 ~~A g~~ Gas safe engine rooms shall be considered as ~~a~~ non-hazardous areas, unless the risk assessment according to Article 30.04 demonstrates otherwise.

#### 3.2.3 Requirements for explosion safe engine rooms

3.2.3.1 Arrangements in explosion safe engine rooms shall be such that the rooms are considered gas safe under normal conditions. A single failure within the LNG system shall not lead to a gas concentration over 20 % of the lower explosive limit (LEL) into the engine room.

3.2.3.2 In the event of gas being detected or the ventilation system failing, the gas supply to the relevant part of the LNG system shall be shut down automatically.

- 3.2.3.3 In addition to the provision of (2.1.6), the ventilation system shall:
- guarantee a sufficient capacity to maintain gas concentration below 20 % of the LEL in the engine room, and to ensure that the gross volume of air inside the engine room can be changed at least 30 times per hour; and
  - be independent of all other ventilation systems of the craft.
- 3.2.3.4 Under normal operation the engine room shall be permanently ventilated with at least 15 changes of the gross volume of air inside the engine room per hour.
- 3.2.3.5 Explosion safe engine rooms shall be designed to provide a geometrical shape that minimises the accumulation of gases or formation of gas pockets. A good air circulation shall be ensured.
- 3.2.3.6 An explosion safe engine room shall be considered as Zone 2, unless the risk assessment according to Article 30.04 demonstrates otherwise.

### 3.2.4 Requirements for the ESD protected engine rooms

- 3.2.4.1 Arrangements in ESD protected engine rooms shall be such that the rooms are considered gas safe under normal conditions, but under certain abnormal conditions may have the potential to become subject to gas hazards.
- 3.2.4.2 In the event of abnormal conditions involving gas hazards, emergency shutdown (ESD) of non-safe equipment (ignition sources) and gas machinery shall be automatically executed, while equipment or machinery in use or active during these conditions shall be of a certified safe type.
- 3.2.4.3 In addition to the provision of (2.1.6), the ventilation system shall:
- guarantee a sufficient capacity to ensure that the gross volume of air inside the engine room can be changed at least 30 times per hour,
  - be designed to handle the probable maximum leakage scenario due to technical failures, and
  - be independent of all other ventilation systems of the craft.
- 3.2.4.4 Under normal operation the engine room shall be permanently ventilated with at least 15 changes of the gross volume of air inside the engine room per hour.  
If gas is detected in the engine room, the number of air changes shall automatically be increased to 30 changes per hour.
- 3.2.4.5 If the craft is equipped with more than one propulsion engine, these engines shall be located in at least two separate engine rooms. These engine rooms shall have no common partitions. However, common partitions may be accepted, if it can be documented that any consequences of a single failure will not affect both rooms.
- 3.2.4.6 Fixed gas warning equipment arranged to automatically shut down the gas supply to the engine room concerned and to disconnect all non-explosion protected equipment or installations shall be fitted.

3.2.4.7 ESD protected engine rooms shall be designed to provide a geometrical shape that minimises the accumulation of gases or formation of gas pockets. A good air circulation shall be ensured.

3.2.4.8 An ESD protected engine rooms shall be considered as Zone 1, unless the risk assessment according to Article 30.04 demonstrates otherwise.

### 3.2.5 Exhaust system

3.2.5.1 The exhaust systems shall be configured to keep accumulation of unburned gaseous fuel as low as possible.

3.2.5.2 Unless designed with the strength to withstand the worst case of overpressure due to ignited gas leaks, engine components or systems that can contain an ignitable gas and air mixture, shall be fitted with suitable pressure relief devices.

3.2.5.3 Means shall be provided to monitor and detect incorrect operation of the ignition system, poor combustion or misfiring that may lead to unburned gaseous fuel in the exhaust system during operation.

~~3.2.5.4 If incorrect operation of the ignition system, poor combustion or misfiring is detected, the gas supply system shall be shut down automatically.~~

3.2.5.5 The exhaust pipes of gas or dual fuel engines shall not be connected to the exhaust pipes of other engines or systems.

~~3.2.5.6 In case of shut-off of the gas supply system in a dual fuel engine, the engine shall be capable of continuous operation on gasoil only without interruption.~~

### 3.2.6 Engines

3.2.6.1 Indicators shall be fitted in the wheelhouse and the engine room for:

- a) operation of the engine in case of a gas-only engine, or
- b) operation and mode of operation of the engine in the case of a dual fuel engine.

3.2.6.2 If incorrect operation of the ignition system, poor combustion or misfiring is detected, the gas supply system shall be shut down automatically.

3.2.6.3 In case of shut-off of the gas supply system in a dual fuel engine, the engine shall be capable of continuous operation on gasoil only without interruption. If the fuel supply is not changed over to gasoil before shutting off the dual fuel engine, the gas supply system from the master fuel valve to the engine and the exhaust system shall be purged in order to discharge any residual gas which may be present.

### Chapter 3

## Propulsion and auxiliary systems with internal combustion engines using methanol as fuel

(left void)

### 3.3.1 General

3.3.1.1 Equipment and piping containing liquid methanol fuel shall be arranged in enclosures, spaces or ducts providing a secondary barrier. This requirement applies notably to pump filters and fittings.

3.3.1.2 The requirements of Annex 8, Section II, (2.2.6), (2.2.7), (2.2.8), (2.2.9), (2.2.11), (2.2.12), (2.2.13) apply also to propulsion and auxiliary systems with internal combustion engines using methanol as fuel.

3.3.1.3 One of the following concepts shall be applied to engine rooms:

- a) gas safe engine room, or
- b) ventilated engine room.

All other spaces where machinery is installed which uses methanol as fuel, such as pump rooms or boiler rooms, shall be subjected to the same requirement as engine rooms.

### 3.3.2 Requirements for gas safe engine rooms

3.3.2.1 Gas safe engine rooms shall be gas safe under all conditions ("inherently safe concept"). A single failure within the methanol system shall not lead to a leakage of methanol into the engine room.

3.3.2.2 Methanol piping and equipment within the engine room boundaries shall be surrounded by a secondary barrier for leakage containment and detection in accordance with the requirements in (a) or (b).

- a) Methanol piping shall be double wall piping with the methanol contained in the inner pipe. The design pressure of the secondary barrier around the inner pipe shall not be less than the maximum working pressure of the inner pipe. As an alternative the secondary barrier around the inner pipe shall be dimensioned in accordance with the calculated maximum built-up pressure in case of pipe rupture. Suitable alarms shall be provided to detect and indicate leakage from the inner pipe. An optical and acoustic alarm shall be triggered in the wheelhouse or at any other permanently manned location in the event of the inner barrier failing or detection of leakage.
- b) Methanol piping and equipment shall be installed within ventilated ducts or enclosures. The interbarrier space between the methanol piping (or equipment) and the wall of the duct or enclosure shall be equipped with mechanical extraction ventilation having a capacity of at least 6 air changes per hour. The ventilation system shall comply with the requirements of (2.2.9).

Methanol leakage inside the ventilated ducts or enclosures shall be detected by means of suitable detectors in accordance with (2.2.13.3). Methanol leakage must be safely collected and drained by means of leakage collecting arrangements. An optical and acoustic alarm shall be triggered in the engine room and in the wheelhouse or at any other permanently manned location in the event of

- aa) the detection of leakage in the interbarrier space,
- or
- bb) the ventilation system failing.

3.3.2.3 Gas safe engine rooms shall be considered as non-hazardous areas, unless the risk assessment according to Article 30.04 demonstrates otherwise.

### **3.3.3 Requirements for ventilated engine rooms**

3.3.3.1 The possible hazardous areas within the ventilated engine rooms shall be classified in accordance with Article 10.04.

3.3.3.2 In accordance with Article 10.04, only equipment suitable for the hazardous areas as classified according to (3.3.3.1) is permitted. This shall be deemed to be fulfilled if the equipment meets the relevant provisions of the European Standard series EN 60079.

3.3.3.3 By way of derogation from (3.3.1.1), the function of the secondary barrier shall be achieved by mechanical ventilation ensuring permanent negative pressure relative to adjacent rooms.

3.3.3.4 In addition to the provision of (2.2.9), the ventilation system shall:

- a) guarantee a sufficient capacity to ensure that the gross volume of air inside the engine room can be changed at least 6 times per hour,
- b) be designed to handle and purge the probable maximum leakage due to technical failures, as assumed for the hazardous areas calculation referred to in (3.3.3.1), and
- c) be independent of all other ventilation systems.

3.3.3.5 In the event of leakage leading to a methanol vapour concentration above 250 ppm in the engine room, an optical and acoustic alarm shall be triggered in

- a) the engine room, and
- b) the wheelhouse or at any other permanently manned location.

3.3.3.6 In the event of leakage leading to a methanol vapour concentration above 40 % of the lower explosion limit (LEL) in the engine room or the ventilation system failing:

- a) the methanol supply to the engine room concerned shall be shut down automatically then
- b) the methanol components in the engine room concerned shall be shut down automatically.



- 3.3.3.7 If the craft is equipped with more than one propulsion engine, these engines shall be located in at least two separate engine rooms. These engine rooms shall have no common partitions. However, common partitions may be accepted, if it can be documented that any consequences of a single failure will not affect both rooms. In accordance with the risk assessment referred to in Article 30.04, the inspection body may allow propulsions engines in the same ventilated engine room, provided that hazardous areas in the ventilated engine room are being determined to be of negligible extent.
- 3.3.3.8 Ventilated engine rooms shall be designed to provide a geometrical shape that minimises gas release from leakage pools as well as the accumulation of gases or formation of gas pockets. Good air circulation shall be ensured. Air inlets and outlets shall be located in appropriate positions, taking into account the characteristics of methanol.
- 3.3.3.9 Suitable alarms shall be provided to detect and indicate a leakage in the engine room, by means of liquid detectors and high sensitivity gas detectors at suitable places, in accordance with (2.2.13.3).
- 3.3.3.10 Drip trays with self-draining lines to closed collecting tanks shall be provided under all equipment which contain methanol and from where leakage cannot be excluded.
- 3.3.3.11 Spray guards shall be provided on pipes and joints where fuel spray cannot be excluded.
- 3.3.3.12 At least two portable methanol detectors shall be available. The safety rota referred to in Article 30.05(1) shall include instructions for the use and calibration of the portable detectors. Doors of ventilated engine rooms shall bear on the outside the following readily legible instruction: 'Access to engine room only with portable methanol detector'.

### **3.3.4 Engines**

- 3.3.4.1 In accordance with (3.3.1.1), engine components containing liquid methanol shall be effectively sealed to prevent leakage of fuel into the engine room.
- 3.3.4.2 For engines where the space below the piston is in direct communication with the crankcase, a detailed evaluation regarding the hazard potential of fuel gas accumulation in the crankcase shall be carried out and reflected in the safety concept of the engine.
- 3.3.4.3 Means shall be provided to monitor and detect incorrect operation of the ignition system, poor combustion and misfiring that may lead to unburnt fuel in the exhaust system or in the crankcase.

3.3.4.4 If incorrect operation of the ignition system, poor combustion or misfiring is detected, the control system shall trigger an optical and acoustic alarm signal in the wheelhouse. A continued operation may only be allowed to ensure the craft of making steerageway under its own power and provided that

- a) the fuel supply to concerned cylinders can be shut off,
- b) the engine manufacturer has declared the engine to be able to operate safely with one or more cylinders cut-off with respect to torsional vibrations, and
- c) the instructions for the boatmaster according to letter a) are displayed in the wheelhouse close to the controls of the engine.

3.3.4.5 In case of an emergency stop or a normal stop, the supply of methanol shall be automatically shut off not later than

- a) the supply of the other fuel for dual fuel engines. It shall not be possible to shut off the other fuel without first or simultaneously closing the methanol supply to the respective cylinders or to the complete engine.
- b) the ignition source for single fuel engines. It shall not be possible to shut off the ignition source without first or simultaneously closing the methanol supply to the respective cylinders or to the complete engine.

### **3.3.5 Exhaust system**

3.3.5.1 Exhaust systems shall be configured to keep accumulation of unburnt fuel as low as possible.

3.3.5.2 Exhaust pipes of methanol engines shall not be connected to exhaust pipes of other engines or systems.

## **Chapter 4**

### **Propulsion and auxiliary systems with internal combustion engines using hydrogen as fuel**

(left void)"

71. ESI-I-2, table, under "Testing" is amended as follows:

a) The current row relating to Article 7.12(11) becomes the row relating to Article 7.12(12):

"

Requirement	Subject matter	Maximum test interval	Inspector
Article 7.12(11)(12)	Elevating wheelhouses and their appliances	1 year	Competent person

"

b) The current row relating to Article 7.12(12) is deleted:

"

Requirement	Subject matter	Maximum test interval	Inspector
<del>Article 7.12(12)</del>	<del>Elevating wheelhouses and their appliances</del>	<del>5 years</del>	<del>Expert</del>

"

c) The row relating to Article 11.08(2) (concerns only the Dutch versions)

72. *In ESI-II-3, Annex 2, (4), the legend for the calculation formulae (concerns only the Dutch and French versions)*

73. ESI-II-10 is worded as follows:

**“ESI-II-10  
AUTOMATIC PRESSURISED WATER SPRINKLER SYSTEMS**

**(Article 13.04(1), and (4) and (5))**

Suitable automatic pressurised water sprinkler systems as in Article 13.04(1), and (4) and (5) shall meet the following requirements:

1. The automatic pressurised water sprinkler systems shall be ready for service at all times when there are persons on board. No additional action by crew members shall be required to trigger operation.
2. The system shall be permanently maintained at the necessary pressure. The pipes shall be filled with water up to the spray nozzles at all times. The system shall have a continuously working water supply. It shall not be possible for impurities harmful to operation to enter the system. Appropriate display instruments and test systems (e.g. pressure gauges, pressure-tank water level indicators, pump test piping) shall be installed for monitoring and checking the system. The pressurised water sprinkler systems located in the cold storage and freezer rooms should not be permanently filled with water. These rooms can be protected with dry sprinklers or filled with appropriate antifreeze.
3. The pump for the water supply to the spray nozzles shall be activated automatically by a pressure drop in the system. The pump shall be dimensioned so that it can continuously provide a sufficient water supply at the necessary pressure if all the spray nozzles necessary for covering the area of the largest room to be protected are activated simultaneously. The pump shall supply the automatic pressurised water sprinkler system exclusively. In the event of pump failure, it shall be possible to provide the spray nozzles with a sufficient water supply from another on-board pump.
4. The system shall be divided into sections, each with no more than 50 spray nozzles. A larger number of spray nozzles may be authorised by the inspection body with appropriate corroboration, in particular a hydraulic calculation.
5. The number and the layout of spray nozzles shall ensure effective distribution of water in the rooms to be protected.
6. Spray nozzles shall be triggered at a temperature between 68.57 °C and 79 °C, in the galley areas at a maximum of 93 °C and in the saunas at a maximum of 141 °C.
7. The installation of components of automatic pressurised water sprinklers system within the rooms to be protected shall be limited to the necessary minimum. No such system components shall be installed in main engine rooms.
8. Optical/Visual and acoustic indicators shall be provided in one or more suitable locations, at least one of which must be permanently manned, displaying activation of automatic pressurised water sprinklers system for each section.

9. The energy supply of the installation of automatic pressurised water sprinklers system shall be provided by two independent energy sources that shall not be installed in the same location. Each energy source shall be capable of supplying the entire system unassisted.
10. An installation plan of the automatic pressurised water sprinkler system shall be presented to the inspection body for examination before installation of the system. The plan shall indicate the types and performance data of the machines and equipment used. A system installation tested and certified by an approved recognised classification society which complies at least with the above prescriptions can be authorised without further testing.
11. The presence of an automatic pressurised water sprinkler system shall be entered in the inland navigation vessel certificate under item 43.”

74. ESI-II-11 is worded as follows:

**“ESI-II-11  
STEERAGEWAY UNDER VESSEL’S OWN POWER**

(Article 7.04(11), Article 9.09(2)(a), (4)(a), (5)(a), Article 11.01(23), (4) and (6), Article 11.02(2),  
Article 11.03(4), Article 11.04(3), Article 11.08(1) and (2), Article 13.05(2)(a) Article 19.07(1)  
Article 28.04(1)(a), Article 30.07)

**1. Minimum requirements for vessel’s steerageway**

Steerageway under a vessel’s own power in accordance with Articles

- 7.04(11)
- 9.09(2)(a), (4)(a), (5)(a),
- 11.01(23), (4) and (6),
- ~~11.02(2),~~
- ~~11.03(4),~~
- 11.04(3),
- 11.08(1) and (2),
- 13.05(2)(a),
- 19.07(1),
- 28.04(1)(a) and
- 30.06

is deemed to be sufficient if the vessel or the formation propelled by the vessel attains a speed of 6,5 km/h in relation to the water and a rate of-turn of 20°/min can be induced and maintained while under way at a speed of 6,5 km/h in relation to the water.

**2. Navigation tests**

On verifying the minimum requirements Articles 5.03 and 5.04 shall be complied with.”

75. *ESI-II-12 is amended as follows:*

a) *The subtitle is worded as follows:*

**“(Article 13.05(3), Article 13.06(2)(b), Article 19.11(18), Article 29.10(1))”.**

b) *(0.7) (concerns only the French version)*

c) *(1.2.1) (concerns only the French version)*

d) *(1.4.2) (concerns only the French version)*

e) *(1.6.1) (concerns only the French version)*

f) *(3.1)(b) (concerns only the French version)*

76. ESI-II-14 is added after ESI-II-13 as follows:

**“ESI-II-14  
COLOUR CODING FOR FILLER NECKS**

**(Articles 8.05(5), 8.06(6), 8.07(5), 15.05(1))**

The filler necks of

- fuel tanks,
- lubricating oil tanks,
- tanks for oils used in power transmission systems, control and activating systems or heating systems and
- potable water installations

must be distinctly marked. It is advisable to distinctly mark other filler necks.

The markings are considered sufficiently clear if, in addition to the prescribed standardised connection piece (for fuels), they are also provided with the following advised unique colour coding.

**Diesel oil**

Brown or Brown/Yellow/Brown if other fuels are available on board (in accordance with international standard ISO 14726: 2008)

**Lubricating oil**

Orange or Orange Yellow Orange if other oils (which are not fuels) are available on board (in accordance with international standard ISO 14726: 2008)

**Hydraulic fluids (power transmission purposes)**

Orange/Grey/Orange (in accordance with international standard ISO 14726: 2008)

**Water (drinking water)**

Blue (in accordance with international standard ISO 14726: 2008)

**Water (fire-fighting)**

Red (in accordance with international standard ISO 14726: 2008)

In order to be visible to those in charge of bunkering, the colour coding can be implemented in different ways:

- a) on the pipe with a coloured self-adhesive tape;
- b) with painted colour stripes; or
- c) by colouring (painting) the pipes throughout their length.

Where the colour coding is implemented in accordance with (a) with self-adhesive tape or (b) with painted colour stripes, such coding shall be implemented at least near the connecting points, and bulkhead and deck penetrations.”



77. *ESI-III-2 (11) (concerns only the French version)*

78. *ESI-III-3 is worded as follows:*

**“ESI-III-3  
STRENGTH OF WATERTIGHT WINDOWS**

**(Article 19.02(16))**

**1. General**

According to Article 19.02(16), watertight windows may be situated below the margin line if they are watertight, cannot be opened, possess sufficient strength and conform to Article 19.06(14).

**2. Construction of watertight windows**

The requirements of Article 19.02(16) are deemed to be fulfilled if the construction of watertight windows complies with the following provisions.

2.1 Only pre-stressed glass complying with International Standard ISO 614 : 2012, shall be used.

2.2 Round windows shall comply with International Standard ISO 1751 : 2012,  
Series Type B: medium-type heavy-duty windows  
Type Model: non-opening windows.

2.3 Angular windows shall comply with International Standard ISO 3903 : 2012,  
Series Type E: heavy-duty windows  
Type Model: non-opening windows.

2.4 ISO Standard windows may be replaced by windows whose construction is at least equivalent to the requirements of (2.1) to (2.3).”

79. *ESI-III-4 (8.1)(b) (concerns only the French version)*

80. *ESI-III-5 is amended as follows:*

- a) *(3.2.2) (concerns only the French version)*
- b) *(3.2.4) (concerns only the French version)*
- c) *(4.1)(b) (concerns only the French version)*

81. *ESI-III-8(2), 1<sup>st</sup> sentence, is worded as follows:*

“For recreational craft subject to Directive 2013/53/EU the inspection body shall as regards to the issuance of the inland navigation vessel certificate (initial inspection) not require further inspection or certification except the requirements of Article 26.01(2)(a) to (f), provided that no modifications to the craft have been carried out since it has been placed to the market, and the Declaration of Conformity refers to the following harmonised Standards or their equivalence:

Article 8.08(2) : EN ISO 15083 : 2023 ~~2018~~, (Bilge pumping)

Article 8.10 : EN ISO 14509-1 : 2018 and  
EN ISO 14509-3 : 2018, (Noise emission)”

82. *ESI-III-10 is amended as follows:*

a) *(2.1)(b) is worded as follows:*

“b) when an alarm is triggered in the wheelhouse be pressurised by means of an auxiliary engine which can be started from the steering position. If the auxiliary engine has its own fuel tank, there shall — in accordance with Article 7.04(11)(e) ~~8.05(13)~~ — be a warning device in the wheelhouse to indicate if the level of filling is not sufficient to ensure further safe operation.”

b) *(2.2) (concerns only the French version)*

c) *(2.3.2) is worded as follows:*

“2.3.2 The daily-supply tank shall have a level alarm device which meets the requirements of Article 7.04(11)(e) ~~8.05(13)~~.”

d) *(2.8)(bb) (concerns only the French version)*

83. *ESI-III-11 is worded as follows:*

**“ESI-III-11  
MATERIALS COMPLYING WITH THE EQUIVALENT REGULATIONS INSTEAD  
OF THE CODE FOR FIRE TEST PROCEDURES**

**(Articles 1.01(6.4), (6.5) and 19.11(1), (2) and (6))**

The European Standards series EN 13501 (meaning EN13501-1 : 2018, EN 13501-2 : 2023, EN 13501-3 : 2009, EN 13501-4 : 2016, EN 13501-5 : 2016 and to EN13501-6 : 2022) and the European Standard EN 45545-2 : 2023 are acceptable test methods for determining the non-flammability of materials, that a material is flame-retardant, or fire resistant, as alternative to the Code for Fire Test Procedures in accordance with Article 19.11(1) of ES-TRIN.

The recognition of other regulations of one of the Member States shall follow the same approach to achieve an acceptable safety level.

**1. All inland vessels**

**1.1 Flame retardant (as defined in Article 1.01(6.5))**

1.1.1 Products which have been tested according to **FTP Code Annex 1, Part 5** are deemed to comply with ES-TRIN (Article 19.11(1)(c)).

1.1.2 Products that have been tested according to European Standards **EN 13501-1 : 2018** may be accepted depending on its classification and use.

Classification **B** (*or higher*) is considered acceptable.

Classification **C** (*or lower*) is not considered acceptable.

1.1.3 Products that have been tested according to European Standard **EN 45545-2 : 2023** may be accepted depending on its classification and use.

Classification **HL2** or **HL3** for requirement R1 are considered equivalent

Classification **HL3** for requirement R10 (flooring) is considered equivalent.

**1.2 Fumes or toxic gases in dangerous quantities**

1.2.1 Products which have been tested according to **FTP Code Annex 1, Part 2, Appendix 1** are acceptable in accordance with ES-TRIN (Article 19.11(6)).

1.2.2 Products that have been tested according to European Standards series **EN 13501-1 : 2018** may be accepted depending on its classification and use.

Classification **s1** may be applied on floorings.

Classification **s2** may be applied on any internal surface (other than floorings).

Classification **s3** is not acceptable.

- 1.2.3 Products that have been tested according to European Standard **EN 45545-2 : 2023** may be accepted depending on its classification and use.

Classification **HL2** or **HL3** for requirement R1 are considered acceptable or equivalent.

Classification **HL3** for requirement R10 (flooring) is considered equivalent.

### **1.3 Non-combustible materials (as defined in Article 1.01(6.4))**

- 1.3.1 Products which have been tested according to **FTP Code Annex 1, Part 1** are deemed to comply with ES-TRIN.

- 1.3.2 Products that have been tested according to European Standard **EN 13501-1 : 2018** may be accepted depending on its classification and use.

Classification **A1** may be applied as non-combustible materials.

Classification **A2** can be described as 'limited combustibility' and may not be applied as non-combustible material.

Classification **B, C, D, E, F** can be described as 'combustible' and may not be applied as non-combustible material.

- 1.3.3 Products that have been listed in **European Commission decision 96/603/EC** (as amended) are acceptable without further testing.

### **1.4 Droplets**

- 1.4.1 Materials for bulkhead, wall and ceiling linings and primary deck coverings shall not produce burning droplets during the test.

- 1.4.2 Products which have been tested according to **FTP Code Annex 1, Part 5** are deemed to comply with ES-TRIN.

- 1.4.3 Products that have been tested according to European Standard **EN 13501-1 : 2018** may be accepted depending on its classification and use.

Classification **d0** is required for all fire protection materials.

Classification **d1 and d2** are not acceptable.

- 1.4.4 Products that have been tested according to European Standard **EN 45545-2 : 2023** may be accepted depending on its classification and use.

Classification **HL2** or **HL3** for requirement R1 are considered acceptable.

## 2. Passenger vessels

- 2.1 Passenger vessels must comply with Article 19.11 which regards to fire protection.
- 2.2 Products which have been tested according to **FTP Code Annex 1, Part 3** are deemed to comply with ES-TRIN.
- 2.3 Materials which have been tested by an accredited test institution according to the European Standards **EN 13501-2 : 2023** and **EN 13501-3 : 2009** may be used on-board based on the following correlations.

FTP Code	EN 13501-2 : 2023 and EN 13501-3 : 2009
B0	E30
B15	combination of E30 and I15
A0	E60
A30	combination of E60 and I30
A60	combination of E60 and I60 (meaning EI60)

**Remark 1:** The integrity E is the ability of the material to withstand fire exposure on one side only, without the transmission of fire to unexposed side as a result of the passage of flames or hot gases. The classification for integrity (E) is acceptable based on the above table. Type A maintains integrity for 1 hour; on this basis, use of “the classification” E60 (i.e. 60 minutes) is accepted. Type B maintains integrity for 30 min; on this basis, use of “the classification” E30 (i.e. 30 minutes) is accepted.

**Remark 2:** The thermal insulation I is the ability of the material to withstand fire exposure on one side only, without the transmission of fire as a result of significant transfer of heat from the exposed side to the unexposed side. The classification for insulation (I) is equivalent to the specified period in which the required temperatures remain within the criteria (see Article 19.11(2)(b)(c)).

**Remark 3:** The above table indicates the minimum classification required under the European Standards series EN 13501. A higher combination of E and I classification is also acceptable.”

84. ESI-III-12 is added after ESI-III-11 as follows:

**“ESI-III-12  
ARRANGEMENTS OF METHANOL FUEL TANKS**

**(Annex 8, (2.2.3) to (2.2.6))**

1. Illustration of typical tank arrangements in accordance with ES-TRIN, Annex 8, (2.2.3) and (2.2.4); other configurations are possible.

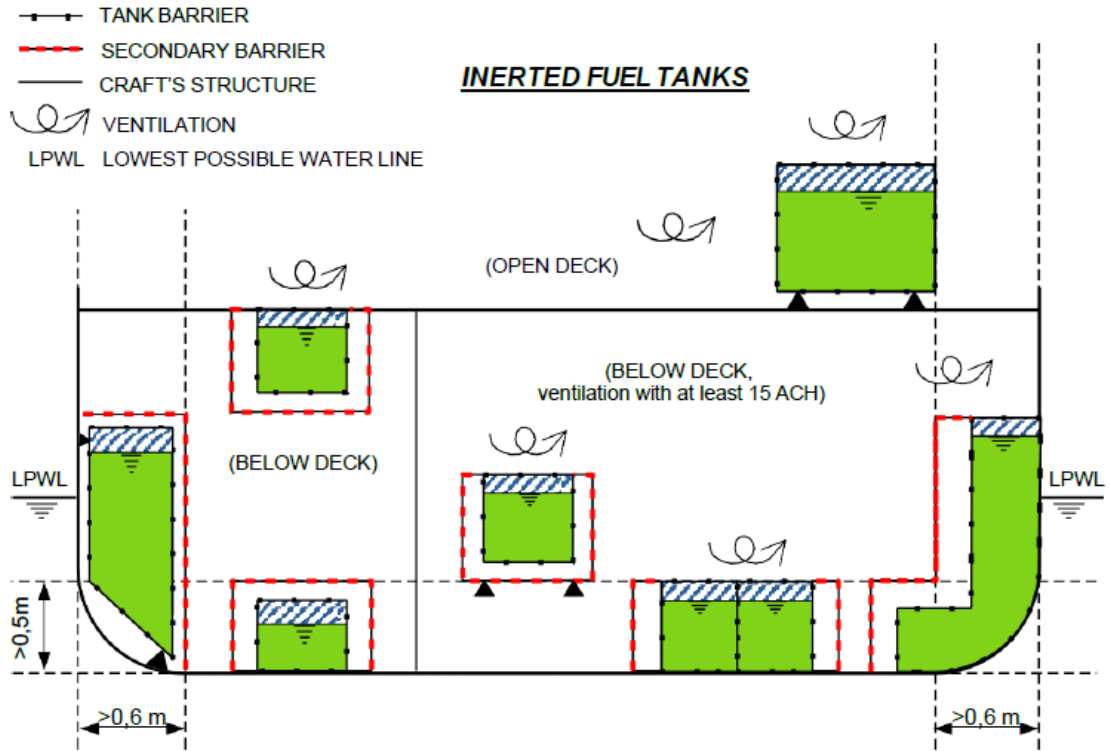

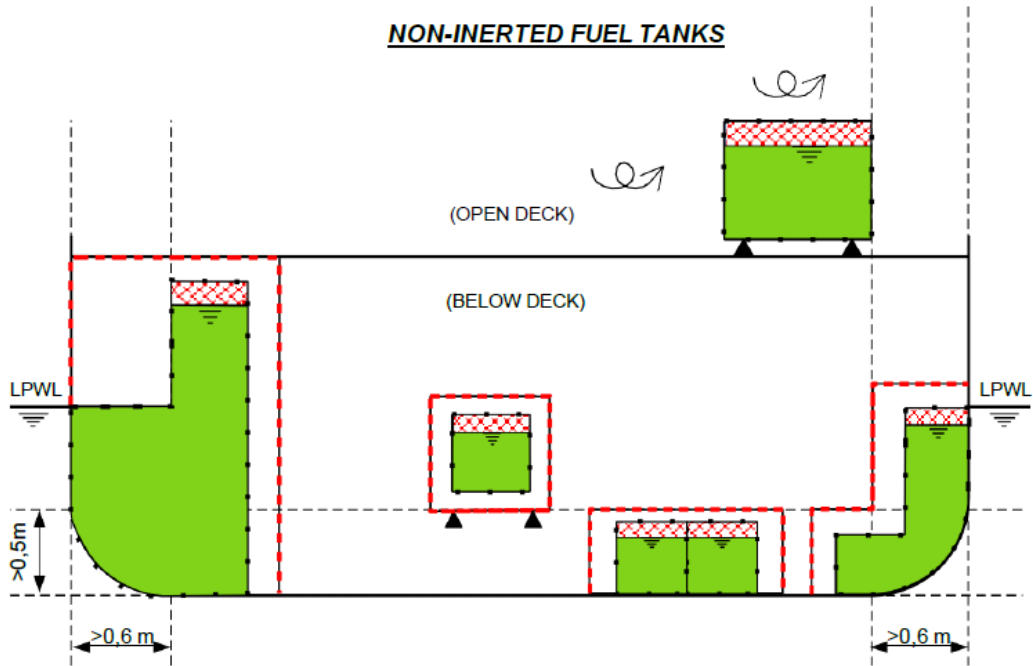

2. Illustration of typical pipe arrangements in accordance with ES-TRIN, Annex 8, (2.2.5) and (2.2.6); other configurations are possible.

