

European Committee for drawing up Standards in the field of Inland Navigation
(CESNI)

Edition 2025/1

**European Standard
for
River Information Services
(ES-RIS)**

TABLE OF CONTENTS

PART 0 COMMON PART	1
CHAPTER 1 ABBREVIATIONS	1
CHAPTER 2 DEFINITIONS	19
CHAPTER 3 REFERENCES	49
PART I ELECTRONIC CHART DISPLAY AND INFORMATION SYSTEM FOR INLAND NAVIGATION (INLAND ECDIS)	55
CHAPTER 1 GENERAL PROVISIONS	55
Article 1.01 General provisions	55
Article 1.02 References	57
CHAPTER 2 GENERAL REQUIREMENTS AND SPECIFICATIONS OF INLAND ECDIS	59
Article 2.01 Contents and provision of chart information	59
Article 2.02 Updating of chart information	60
Article 2.03 Presentation of information	60
Article 2.04 Operation	79
Article 2.05 Service functions	84
Article 2.06 Hardware requirements	85
Article 2.07 Connection of other equipment	87
Article 2.08 Warning and alarm indicators	88
Article 2.09 Fall-back arrangements	89
Article 2.10 Quality requirements	90
Article 2.11 Changes to certified navigation systems	91
CHAPTER 3 SYSTEM CONFIGURATIONS (FIGURES)	93
CHAPTER 4 DATA STANDARD FOR IENCs	95
Article 4.01 Introduction	95
Article 4.02 Theoretical data model	95
Article 4.03 Data structure	95
Article 4.04 Product specifications for IENCs and bathymetric IENCs	95
Article 4.05 Validation Checks	96
CHAPTER 5 CODES FOR PRODUCERS AND WATERWAYS (IN ADDITION TO REF#IHO-S62 ENC PRODUCER CODES)	97
CHAPTER 6 PRESENTATION STANDARD FOR INLAND ECDIS	99
Article 6.01 Introduction	99
Article 6.02 The presentation library for Inland ECDIS	99
PART II VESSEL TRACKING AND TRACING FOR INLAND NAVIGATION	103
CHAPTER 1 GENERAL PROVISIONS	103
Article 1.01 Introduction	103
Article 1.02 References	103
Article 1.03 Definitions	103
Article 1.04 Vessel Tracking and Tracing services and minimum requirements of Vessel Tracking and Tracing systems	103
CHAPTER 2 INLAND VESSEL TRACKING AND TRACING FUNCTIONS	105
Article 2.01 Introduction	105
Article 2.02 Navigation	105

<i>Article 2.03 Vessel traffic management</i>	106
<i>Article 2.04 Calamity abatement</i>	108
<i>Article 2.05 Transport management</i>	109
<i>Article 2.06 Enforcement</i>	109
<i>Article 2.07 Waterway dues and port infrastructure charges</i>	110
<i>Article 2.08 Information needs</i>	110
CHAPTER 3 INLAND AIS TECHNICAL SPECIFICATION	113
<i>Article 3.01 Introduction</i>	113
<i>Article 3.02 Scope</i>	114
<i>Article 3.03 Requirements</i>	115
<i>Article 3.04 Protocol amendments for Inland AIS mobile station</i>	120
<i>Article 3.05 Inland AIS Application Specific Messages</i>	126
CHAPTER 4 OTHER AIS MOBILE STATIONS ON INLAND WATERWAYS	133
<i>Article 4.01 Introduction</i>	133
<i>Article 4.02 General requirements for AIS Class B mobile stations on inland waterways</i>	133
CHAPTER 5 AIS AIDS TO NAVIGATION IN INLAND NAVIGATION	135
<i>Article 5.01 Introduction</i>	135
<i>Article 5.02 Use of Message 21: Aids to Navigation report</i>	137
<i>Article 5.03 Extension of Message 21 with inland-specific type of AtoN</i>	141
PART III NOTICES TO SKIPPERS	147
CHAPTER 1 GENERAL PROVISIONS	147
<i>Article 1.01 Definitions</i>	147
<i>Article 1.02 Primary functions and performance requirements for Notices to Skippers (NtS)</i>	147
CHAPTER 2 PROVISION OF NOTICES TO SKIPPERS	149
CHAPTER 3 NTS MESSAGE TYPES	151
CHAPTER 4 STRUCTURE OF NTS AND ENCODING OF NTS MESSAGES	153
<i>Article 4.01 General structure</i>	153
<i>Article 4.02 Explanation of XML tags and code values in the NtS Reference Tables</i>	156
<i>Article 4.03 Identification of fairway sections and objects in NtS messages</i>	156
<i>Article 4.04 Rules for encoding of NtS messages</i>	157
PART IV ELECTRONIC SHIP REPORTING IN INLAND NAVIGATION	159
CHAPTER 1 MESSAGE IMPLEMENTATION MANUAL CONVENTION	159
<i>Article 1.01 Introduction</i>	159
<i>Article 1.02 UN/EDIFACT message structure</i>	160
<i>Article 1.03 XML/XSD message structure</i>	160
<i>Article 1.04 Introduction to message types</i>	160
CHAPTER 2 CODES AND REFERENCES	163
<i>Article 2.01 Introduction</i>	163
<i>Article 2.02 Definitions</i>	163
<i>Article 2.03 Classifications and code descriptions</i>	163
<i>Article 2.04 Location codes</i>	164
<i>Article 2.05 List of abbreviations</i>	164

PART V INLAND ECDIS OPERATIONAL AND PERFORMANCE REQUIREMENTS, METHODS OF TEST AND REQUIRED TEST RESULTS (TEST PART OF INLAND ECDIS)	165
CHAPTER 1 SCOPE	165
CHAPTER 2 REFERENCES	167
CHAPTER 3 ABBREVIATIONS	169
CHAPTER 4 GENERAL REQUIREMENTS	171
Article 4.01 Ordering principles of the clauses	171
Article 4.02 General preconditions and test equipment	172
CHAPTER 5 OPERATIONAL AND PERFORMANCE REQUIREMENTS, METHODS OF TEST AND REQUIRED TEST RESULTS COMMON TO ALL MODES OF INLAND ECDIS	175
Article 5.01 Content of IENC	175
Article 5.02 Updates	176
Article 5.03 Screen orientation, chart orientation, positioning and shifting	177
Article 5.04 Display of SENC information	177
Article 5.05 Colours and symbols	179
Article 5.06 Scale dependent information density (SCAMIN)	180
Article 5.07 Features displayed in several cells with the same use for the same area	180
Article 5.08 Display of tracking and tracing information	181
Article 5.09 Display of AIS targets of other vessels	181
Article 5.10 Display of AIS Aids to Navigation	184
Article 5.11 Operation	190
Article 5.12 Ergonomics of control elements	191
Article 5.13 Characteristics of control elements	192
Article 5.14 Pick report	192
Article 5.15 Measuring features	193
Article 5.16 Input and editing of boatmasters' own chart entries	193
Article 5.17 Control elements	194
Article 5.18 Operation of AIS targets of other vessels	196
Article 5.19 Service functions	196
Article 5.20 Display	197
Article 5.21 Display colours	198
Article 5.22 Display and screen brightness	198
Article 5.23 Connection of other equipment	199
Article 5.24 Configuration of interfaces	200
Article 5.25 Documentation	202
Article 5.26 Interfaces	202
CHAPTER 6 ADDITIONAL OPERATIONAL AND PERFORMANCE REQUIREMENTS, METHODS OF TEST AND REQUIRED TEST RESULTS FOR INLAND ECDIS IN INFORMATION MODE	205
Article 6.01 Operation	205
Article 6.02 Screen dimensions	205
Article 6.03 Screen resolution	206
Article 6.04 Malfunctions	206
Article 6.05 Documentation	207
Article 6.06 Interfaces	208
CHAPTER 7 ADDITIONAL OPERATIONAL AND PERFORMANCE REQUIREMENTS, METHODS OF TEST AND REQUIRED TEST RESULTS FOR INLAND ECDIS IN NAVIGATION MODE	209
Article 7.01 Updates	209
Article 7.02 Image positioning and orientation	209
Article 7.03 Screen orientation, chart orientation, positioning and shifting	210
Article 7.04 Position and heading of the own vessel	211
Article 7.05 Display of SENC information	211
Article 7.06 Display of radar information	213
Article 7.07 Data and display accuracy	215

<i>Article 7.08 Position accuracy</i>	216
<i>Article 7.09 Heading accuracy</i>	218
<i>Article 7.10 Operation</i>	219
<i>Article 7.11 Ergonomics of control elements</i>	220
<i>Article 7.12 Input and editing of boatmasters' own chart entries</i>	221
<i>Article 7.13 Scales, Ranges/Range rings</i>	222
<i>Article 7.14 Inland ECDIS pre-sets (store/recall) in navigation mode</i>	224
<i>Article 7.15 Control elements</i>	224
<i>Article 7.16 Service functions</i>	224
<i>Article 7.17 Hardware requirement</i>	225
<i>Article 7.18 Display</i>	226
<i>Article 7.19 Screen dimensions</i>	227
<i>Article 7.20 Screen resolution</i>	227
<i>Article 7.21 Display and screen brightness</i>	228
<i>Article 7.22 Picture refresh rate</i>	228
<i>Article 7.23 Connection of other equipment</i>	229
<i>Article 7.24 Accuracy of rate of turn indicators</i>	230
<i>Article 7.25 Built-in Test Equipment (BITE)</i>	230
<i>Article 7.26 Malfunctions</i>	231
<i>Article 7.27 Insufficient accuracy of the SENC-positioning</i>	233
<i>Article 7.28 Defects</i>	233
<i>Article 7.29 Endurance test</i>	234
<i>Article 7.30 Documentation</i>	235
CHAPTER 8 TEST DESCRIPTIONS	237
<i>Article 8.01 Test charts and test scenarios</i>	237
<i>Article 8.02 AIS protocol simulator</i>	239
<i>Article 8.03 GNSS protocol simulator</i>	240
<i>Article 8.04 Heading protocol simulator</i>	240
<i>Article 8.05 Additional sensor protocol simulator</i>	241
<i>Article 8.06 AIS protocol manipulator</i>	241
<i>Article 8.07 GNSS protocol manipulator</i>	241
<i>Article 8.08 Heading protocol manipulator</i>	242
<i>Article 8.09 AtoN protocol simulator</i>	242
CHAPTER 9 RELATIONSHIP BETWEEN REQUIREMENTS AND CLAUSES	243
PART VI INLAND AIS EQUIPMENT OPERATIONAL AND PERFORMANCE REQUIREMENTS, METHODS OF TEST AND REQUIRED TEST RESULTS (TEST PART OF INLAND AIS)	247
CHAPTER 1 SCOPE	247
CHAPTER 2 NORMATIVE REFERENCES	249
CHAPTER 3 ABBREVIATIONS	251

Shipborne Inland AIS stations

CHAPTER 4 SHIPBORNE INLAND AIS STATIONS- GENERAL REQUIREMENTS	253
Article 4.01 Class A functions not required	253
Article 4.02 Functions in addition to Class A	253
Article 4.03 Manuals.....	253
CHAPTER 5 SHIPBORNE INLAND AIS STATIONS - ENVIRONMENTAL, POWER SUPPLY, SPECIAL PURPOSE AND SAFETY REQUIREMENTS	255
CHAPTER 6 SHIPBORNE INLAND AIS STATIONS- PERFORMANCE REQUIREMENTS	257
Article 6.01 Composition	257
Article 6.02 Information	258
Article 6.03 Information processing.....	258
Article 6.04 Minimum Keyboard and Display (MKD).....	261
CHAPTER 7 SHIPBORNE INLAND AIS STATIONS - TECHNICAL REQUIREMENTS.....	265
Article 7.01 Response to Assignment Commands.....	265
Article 7.02 Presentation interface	265
CHAPTER 8 SHIPBORNE INLAND AIS STATIONS - OPERATIONAL TESTS	269
Article 8.01 Operating modes/capability.....	269
Article 8.02 Reporting intervals	269
Article 8.03 Alarms and indicators, fall-back arrangements.....	270
Article 8.04 Input of Data on MKD.....	270
Article 8.05 Display of Data on MKD.....	270
CHAPTER 9 SHIPBORNE INLAND AIS STATIONS - SPECIFIC TESTS OF LINK LAYER	271
Article 9.01 Group assignment.....	271
Article 9.02 Inland AIS message formats.....	273
CHAPTER 10 SHIPBORNE INLAND AIS STATIONS - HIGH SPEED INPUT	279
Article 10.01 Voyage data configuration	279
Article 10.02 Static data configuration.....	279
CHAPTER 11 SHIPBORNE INLAND AIS STATIONS - LONG RANGE FUNCTIONALITY TESTS.....	281

Inland AIS AtoN stations

CHAPTER 12 INLAND AIS ATON STATIONS - REQUIREMENTS	283
Article 12.01 General requirements	283
Article 12.02 Performance requirements.....	283
Article 12.03 Configuration method.....	283
CHAPTER 13 INLAND AIS ATON STATIONS – TEST OF PHYSICAL INLAND AIS ATON STATION	285
Article 13.01 Aim	285
Article 13.02 Requirements.....	285
Article 13.03 Method of tests.....	286
Article 13.04 Required results	286

Annexes

ANNEX 1	PRODUCT SPECIFICATION FOR IENCS, EDITION 2.5	293
APPENDIX 1	IENC FEATURE CATALOGUE, EDITION 2.5.1	
APPENDIX 2	ENCODING GUIDE FOR IENCS, EDITION 2.5.1	
ANNEX 2	PRESENTATION LIBRARY FOR IENCS, EDITION 2.5.....	329
ANNEX 3	PRODUCT SPECIFICATION FOR BATHYMETRIC IENCS, EDITION 2.5	353

ANNEX 4	IENC VALIDATION CHECKS.....	363
ANNEX 5	COMPARISON OF THE STRUCTURES OF THE STANDARD FOR MARITIME ECDIS AND OF ES-RIS	449
ANNEX 6	(LEFT VOID).....	451
ANNEX 7	(LEFT VOID).....	453
ANNEX 8	(LEFT VOID).....	455
ANNEX 9	DIGITAL INTERFACE SENTENCES FOR INLAND AIS	459
ANNEX 10	INLAND VESSEL AND CONVOY TYPES.....	461
ANNEX 11	(INFORMATIVE) BLOCK DIAGRAM OF AIS	465
ANNEX 12	(NORMATIVE) AIS INTERFACE OVERVIEW.....	467
ANNEX 13	(NORMATIVE) ADDITIONAL PI PORT SENTENCES FOR INLAND AIS.....	469
ANNEX 14	VESSEL DIMENSIONS	471
ANNEX 15	INLAND AIS MESSAGES.....	473
APPENDIX 1	CONVOY FORMATION CODES	
ANNEX 16	(LEFT VOID).....	515
ANNEX 17	(LEFT VOID).....	517
ANNEX 18	(LEFT VOID).....	519
ANNEX 19	ELECTRONIC REPORTING DATA DEFINITIONS	523
ANNEX 20	(DANGEROUS) GOODS REPORTING – ERINOT.....	549
APPENDIX 1	XML EDITION OF ERINOT, XSD FILE (SOURCE CODE)	
ANNEX 21	PASSENGER AND CREW LIST – PAXLST.....	557
APPENDIX 1	PAXLST MESSAGE IN XML FORMAT, XSD FILE (SOURCE CODE)	
ANNEX 22	ERI RESPONSE AND RECEIPT MESSAGE – ERIRSP.....	589
APPENDIX 1	XML FORMAT OF ERIRSP MESSAGE, XSD FILE (SOURCE CODE)	
ANNEX 23	BERTH MANAGEMENT PORT NOTIFICATION – BERMAN	607
ANNEX 24	VOYAGE PLAN NOTIFICATION – ERIVROY	647
APPENDIX 1	XML FORMAT OF ERIVROY MESSAGE, XSD FILE (SOURCE CODE)	
ANNEX 25	(LEFT VOID).....	653
ANNEX 26	(LEFT VOID).....	655
ANNEX 27	(LEFT VOID).....	657
ANNEX 28	NOTICES TO SKIPPERS ENCODING GUIDE FOR EDITORS	661
ANNEX 29	NOTICES TO SKIPPERS ENCODING GUIDE FOR APPLICATION DEVELOPERS	683
ANNEX 30	STANDARDISED NOTICES TO SKIPPERS EXTENDED MARKUP LANGUAGE (XML) SCHEMA DEFINITION (XSD)	711
APPENDIX 1	NTS, XSD FILE (SOURCE CODE)	
ANNEX 31	NOTICES TO SKIPPERS WEB SERVICE SPECIFICATION (WSDL)	713
APPENDIX 1	NTS, WSDL	
ANNEX 32	NOTICES TO SKIPPERS REFERENCE TABLES (TAGS)	715
APPENDIX 1	NTS REFERENCE TABLES (TAGS)	

PART 0 COMMON PART

CHAPTER 1 ABBREVIATIONS

The table below gives all abbreviations used in the different parts of ES-RIS.

Each abbreviation is given in 4 languages and the table is sorted with English abbreviations. When the abbreviation is the same in all 4 languages, it appears only once.

The second column gives the meaning of the abbreviation in the current language.

The column "Definition" says if the term is defined in Chapter 2 of this Part.

Abbreviation	Stands for	Defined	Used in parts
ADN	European Agreement concerning the International Carriage of Dangerous Goods by Inland Waterways Accord européen relatif au transport international des marchandises dangereuses par voies de navigation intérieures Europäisches Übereinkommen über die internationale Beförderung gefährlicher Güter auf Binnenwasserstraßen Europese overeenkomst voor het internationale vervoer van gevaarlijke goederen over de binnenwateren	X	II, IV
ADR	European Agreement concerning the International Carriage of Dangerous Goods by Road Accord européen relatif au transport international des marchandises Dangereuses par Route Europäisches Übereinkommen über die internationale Beförderung gefährlicher Güter auf der Straße Europese overeenkomst voor het internationale vervoer van gevaarlijke goederen over de weg		IV
AI	Application Identifier Identifiant d'application Anwendungskennung Applicatie-Identificatie		II, VI
AIS	Automatic Identification System Système d'identification automatique Automatisches Identifikationssystem Automatisch IdentificatieSysteem	X	I, II, V, VI

Abbreviation	Stands for	Defined	Used in parts
ASCII	American Standard Code for Information Interchange Code normalisé américain pour les échanges de données Amerikanischer Standard-Code für den Informationsaustausch Amerikaanse standaardcode voor informatie-uitwisseling		II
ASM	Application Specific Message Message spécifique aux applications Anwendungsspezifische Meldung Specifiek applicatiebericht		II
AtoN	Aid to Navigation Aide à la navigation Navigationshilfe Navigatiehulpmiddel		I, II, V, IV
BERMAN	Berth management (port notification)Gestion des postes à quai (notification au port) Liegeplatzmanagement (Hafenmeldung) Kadebeheer (havenaanmelding)		IV
biENC	bathymetric IENC CENI bathymétrique Bathymetrische IENC Bathymetrische IENC	X	I, V
BIIT	Built-in Integrity Test Test d'intégrité intégré Eingebauter Selbsttest Ingebouwde Integriteitstest		V, VI
CCNR	Central Commission for the Navigation of the Rhine		IV
CCNR	Commission centrale pour la navigation du Rhin		
ZKR	Zentralkommission für die Rheinschifffahrt		
CCR	Centrale Commissie voor de Rijnvaart		

Abbreviation	Stands for	Defined	Used in parts
CESNI	European Committee for drawing up Standards in the field of Inland Navigation Comité européen pour l'élaboration de standards dans le domaine de la navigation intérieure Europäischer Ausschuss zur Ausarbeitung von Standards im Bereich der Binnenschifffahrt Europees Comité voor de opstelling van standaarden voor de binnenvaart		V, VI
COG	Course over Ground Route sur le fond Kurs über Grund Koers over de grond		VI
DAC	Designated Area Code Code de zone désigné Gebietscode Vastgestelde gebiedscode		II, VI
DGNSS	Differential GNSS GNSS différentiel Differential-GNSS Differentieel GNSS		II, V, VI
DOP	Dilution of Precision Dilution de précision Dilution of Precision Verzwakking van nauwkeurigheid		V
DSC	Digital Selective Calling Appel sélectif numérique Digitaler Selekturf Digitale selectieve oproep		VI
DWT	Deadweight tonnage Port en lourd Tragfähigkeit Ton draagvermogen		IV

Abbreviation	Stands for	Defined	Used in parts
EBL	Electronic Bearing Line Ligne de relèvement électronique Elektronische Peillinie Elektronische peillijn		I, V
ECDIS	Electronic Chart Display and Information System Système de visualisation de cartes électroniques et d'informations Elektronisches Kartendarstellungs- und Informationssystem Systeem voor deelektronische weergave van kaarten en informatie	X	I, V, VI
EDI	Electronic data interchange Échange de données informatisé Elektronischer Datenaustausch Elektronische gegevensuitwisseling	X	IV
EN	European Standard Norme européenne Europäische Norm Europese norm		I
ENC	Electronic Navigational Chart	X	I, V
CEN	Carte électronique de navigation		
ENC	Elektronische Navigationskarte		
ENC	Elektronische navigatiekaart		
ENI	Unique European vessel identification number Numéro européen unique d'identification des bateaux Einheitliche europäische Schiffsnummer Uniek Europees scheepsidentificatienummer	X	IV, VI
EPFD	Electronic Position Fixing Device Appareil électronique de détermination de la position Elektronisches Positionsbestimmungsgerät Elektronisch positiebepalingsapparaat		V
EPFS	Electronic Position Fixing System Système électronique de détermination de la position Elektronisches Positionsbestimmungssystem Elektronisch positiebepalingssysteem		VI

Abbreviation	Stands for	Defined	Used in parts
ERDMS	European Reference Data Management Service Système européen de gestion des données de référence Europäisches Referenzdatenverwaltungssystem Europees beheersysteem voor referentiegegevens		IV
ERI	Electronic Reporting International Notification électronique internationale Elektronische Meldungen international Internationale elektronische rapportage	X	II, IV
ERINOT	ERI Notification (message) Notification ERI (message) ERI-Anmeldung (Nachricht) ERI-kennisgeving (bericht)		IV
ERIRSP	ERI response (message) Réponse ERI (message) ERI-Antwort und -Empfangsbestätigung (Nachricht) ERI-antwoord (bericht)		IV
ES-TRIN	European Standard laying down Technical Requirements for Inland Navigation vessels Standard européen établissant les prescriptions techniques des bateaux de navigation intérieure Europäischer Standard der technischen Vorschriften für Binnenschiffe Europese standaard tot vaststelling van de technische voorschriften voor binnenschepen		V, VI
ETA	Estimated Time of Arrival Heure d'arrivée prévue Geschätzte Ankunftszeit Geschatte aankomsttijd		IV, VI
ETD	Estimated Time of Departure Heure de départ prévue Geschätzte Abfahrtszeit Geschatte vertrektijd		IV

Abbreviation	Stands for	Defined	Used in parts
ETSI	European Telecommunications Standards Institute Institut européen des normes de télécommunications Europäisches Institut für Telekommunikationsnormen Europees Instituut voor telecommunicatienormen		I, V
EUT	Equipment Under Test Appareil soumis à l'essai Zu prüfendes Gerät Te testen apparatuur		I, V, VI
FI	Functional Identifier Identifiant de fonction Funktionskennung Functie-identificatie		II, VI
FIS	Fairway Information Services Service d'information sur les chenaux Wasserstraßeninformationsdienste Vaarweginformatiediensten		III
FTM	Fairway and Traffic related Message Message relatif à la voie navigable et au trafic Fahrrinnen- und verkehrsbezogene Nachricht Bericht met betrekking tot vaarwegen en verkeer		III
GLONASS	(Russian) Global Navigation Satellite System Système (russe) de navigation par satellite (russisches) Globales Satellitennavigationssystem (Russisch) wereldwijd satellietnavigatiesysteem		II
GNSS	Global Navigation Satellite System Système mondial de navigation par satellite Globales Satellitennavigationssystem Wereldwijd satellietnavigatiesysteem	X	I, II, V, VI
GPS	(United States) Global Positioning System Système de positionnement mondial (américain) Globales Positionierungssystem (Amerikaans) wereldwijd plaatsbepalingssysteem		II, V, VI

Abbreviation	Stands for	Defined	Used in parts
GRT	Gross Tonnage		
GRT	Tonnage brut	X	IV
BRZ	Bruttoreumzahl		
GRT	Brutotonnage		
HDG	Heading		
	Cap	X	I, II, V
	Heading		
	Vaarrichting (koers)		
IAI	International Application Identifier		
	Identifiant d'application internationale		II
	internationale Anwendungskennung		
	internationale applicatie-identificatie		
IALA	International Association of Lighthouse Authorities		
	Association Internationale de Signalisation Maritime		V
	Internationale Seezeichenvereinigung		
	Internationale Associatie van vuurtoreninstanties		
ID	Identifier		
	Identifiant		II, VI
	Kennung		
	Identificatie		
IEC	International Electrotechnical Commission		
CEI	Commission électrotechnique internationale	X	I, V, VI
IEC	Internationale Elektrotechnische Kommission		
IEC	Internationale Elektrotechnische Commissie		
IENC	Inland Electronic Navigational Chart		
CENI	Carte électronique de navigation intérieure	X	I, V
IENC	Elektronische Navigationskarte für die Binnenschifffahrt		
IENC	Elektronische navigatiekaart voor de binnenvaart		
IFM	International function message (DAC 001)		
	Message de fonction international (DAC 001)		VI
	Internationale Funktionsmeldung (DAC 001)		
	Internationaal functiebericht (DAC 001)		

Abbreviation	Stands for	Defined	Used in parts
IFTDGN	International forwarding and transport dangerous goods notification (message)		
	Notification de l'expédition et du transport internationaux de marchandises dangereuses (message)		IV
	Internationale Speditions- und Transportanmeldung für gefährliche Güter (Nachricht)		
	Internationale kennisgeving van verzending en vervoer van gevaarlijke goederen (bericht)		
IHO	International Hydrographic Organisation		
OHI	Organisation hydrographique internationale	X	I, V
IHO	Internationale Hydrografische Organisation		
IHO	Internationale Hydrografische Organisatie		
IMDG	International maritime dangerous goods code (number)		
	Code maritime international pour le transport des marchandises dangereuses (numéro)		IV
	Internationaler Code für die Beförderung gefährlicher Güter mit Seeschiffen (Nummer)		
	Internationale code voor het vervoer van gevaarlijke stoffen over zee		
IMO	International Maritime Organisation		
OMI	Organisation maritime internationale		I, IV, V, VI
IMO	Internationale Seeschiffahrtsorganisation		
IMO	Internationale Maritieme Organisatie		
IMO-FAL	IMO convention on the Facilitation of International Maritime Traffic, 1965, with amendments		
	Convention de l'OMI visant à faciliter le trafic maritime international (1965), et ses amendements		IV
	IMO-Übereinkommen zur Erleichterung des internationalen Seeverkehrs, 1965, in der geltenden Fassung		
	IMO-Verdrag inzake het vergemakkelijken van het internationale verkeer ter zee, 1965, met wijzigingen		
ISO	International Standardisation Organisation		
	Organisation internationale de normalisation		IV
	Internationale Organisation für Normung		
	Internationale -Organisatie voor normalisatie		

Abbreviation	Stands for	Defined	Used in parts
ISPS code	International ship and port facility security code Code international pour la sûreté des navires et des installations portuaires Internationaler Code für die Gefahrenabwehr auf Schiffen und in Hafenanlagen Internationale code voor de beveiliging van schepen en havenfaciliteiten		IV
ISRS	International Ship Reporting Standard Standard international pour les annonces électroniques des bateaux Internationaler Schiffsmeldestandard Internationale standaard voor scheepsrapportage	X	II, III, IV
ITU	International Telecommunication Union		
UIT	Union internationale des télécommunications		II, V, VI
ITU	Internationale Fernmeldeunion		
ITU	Internationale Telecommunicatie-unie		
LOCODE	UNECE location code for ports and freight stations Code des ports et autres lieux de la CEE-ONU Ortscode der UNECE (für Häfen und Frachtanlagen) Locatiecode van de VN-ECE voor havens en vrachtstations		IV
LR	Long Range Longue portée Weitbereich Lange afstand		VI
MHz	Megahertz (Megacycles per second) Megahertz (mégacycles par seconde) Megahertz (Megazyklen pro Sekunde) Megahertz (megacycli per seconde)		VI
MID	Maritime Identification Digit Identifiant de radiocommunication maritime Seefunkkennzahl Maritiem identificatiecijfer		II

Abbreviation	Stands for	Defined	Used in parts
MKD	Minimum Keyboard and Display Interface minimum de saisie et d'affichage Mindestanzeige- und Bedienelement Minimaal toetsenbord en display		VI
MMSI	Maritime Mobile Service Identity Identité dans le service mobile maritime Seemobildienstkennung Identiteitsnummer voor maritieme mobiele diensten	X	II, VI
NtS	Notices to Skippers Avis à la batellerie Nachrichten für die Binnenschifffahrt Berichten aan de scheepvaart		III
PA	Position Accuracy Degré de précision Präzisionsgenauigkeit Positienauwkeurigheid		V
PAXLST	Passenger list (message) Liste des passagers (message) Fahrgastliste (Nachricht) Passagierslijst (bericht)		IV
PI	Presentation interface Interface de présentation Darstellungsschnittstelle Presentatie interface		VI

Abbreviation	Stands for	Defined	Used in parts
PROTECT ¹	International Organisation of North Europeans Ports dealing with dangerous goods message implementation Organisation internationale des ports de l'Europe du Nord qui gère la mise en œuvre des messages relatifs aux marchandises dangereuses Nachrichtenimplementierung der internationalen Organisation nordeuropäischer Häfen, die mit gefährlichen Gütern umgehen Internationale Organisatie van Noord-Europese havens die de uitvoering behandelt van berichten over gevaarlijke goederen		IV
RAI	Regional Application Identifier Identifiant d'applications régionales Regionale Anwendungskennung Regionale applicatie-identificatie		VI
RAIM	Receiver Autonomous Integrity Monitoring Surveillance autonome de l'intégrité du récepteur Autonome empfangenseitige Integritätsüberwachung Autonome ontvangers voor de controle van de integriteit		VI
RF	Radio frequency Fréquence radio Funkfrequenz Radiofrequentie		VI
RFM	(Inland specific) Regional Function Message (DAC 200) Messages de fonctions régionales (spécifique à la navigation intérieure) (DAC 200) Binnenschiffahrtsspezifische) regionale Funktionsmeldung (DAC 200) (Specifiek) regionaal functiebericht (voor de binnenvaart) (DAC 200)		VI

¹ PROTECT is used as an acronym, always in capital letters but is more of a name as the letters do not match the corresponding meaning.
PROTECT est utilisé comme acronyme, toujours en lettres capitales, mais il s'agit plutôt d'un nom car les lettres ne correspondent pas à la signification correspondante.
PROTECT wird immer in Großbuchstaben wie eine Abkürzung verwendet, auch wenn es sich eigentlich um eine Bezeichnung handelt, da die Buchstaben die Bedeutung nicht abbilden.
PROTECT wordt gebruikt als acroniem, altijd in hoofdletters, maar is meer een naam omdat de letters niet overeenkomen met de bijbehorende betekenis.

Abbreviation	Stands for	Defined	Used in parts
RID	Regulations Concerning the International Carriage of Dangerous Goods by Rail Règlement concernant le transport international ferroviaire des marchandises dangereuses Ordnung für die internationale Eisenbahnbeförderung gefährlicher Güter Reglement betreffende het internationaal vervoer van gevaarlijke goederen per spoor		IV
RIS	River Information Services		
SIF	Services d'information fluviale	X	IV, V, VI
RIS	Binnenschiffahrtsinformationsdienste		
RIS	Rivierinformatiediensten		
ROT	Rate of Turn Vitesse de giration Wendegeschwindigkeit Draaisnelheid	X	I, II, V, VI
RTA	Requested Time of Arrival Heure d'arrivée requise angefragte Ankunftszeit Gewenste aankomsttijd		VI
RTCM	Radio Technical Commission for Maritime Services Commission radiotechnique pour les services maritimes Funktechnikkommission für Seefunkdienste Radiotechnische Commissie voor maritieme diensten		VI
Rx	Receive Réception Empfang Ontvangen		VI
SAR	Search and Rescue Recherche et sauvetage Suche und Rettung Opsporing en redding		V, VI
SENC	System Electronic Navigational Chart		
CENS	Carte électronique de navigation spécifique au système		I, V
SENC	Systemspezifische Elektronische Navigationskarte		
SENC	Systeemspezifieke elektronische navigatiekaart		

Abbreviation	Stands for	Defined	Used in parts
SOAP	Simple Object Access Protocol	X	III
	Simple Object Access Protocol		
	Simple Object Access Protocol		
	Simple Object Access Protocol		
SOG	Speed over Ground		VI
	Vitesse par rapport au fond		
	Geschwindigkeit über Grund		
	Snelheid over de grond		
SOLAS	Safety of Life at Sea		II, IV, VI
	Sauvegarde de la vie humaine en mer		
	Sicherheit des menschlichen Lebens auf See		
	Beveiliging van mensenlevens op zee		
SQRT	Square root		II
	Racine carrée		
	Quadratwurzel		
	Vierkantswortel		
STI	Strategic Traffic Information	X	II
	Informations stratégiques de trafic		
	Strategische Verkehrsinformation		
	Strategische verkeersinformatie		
TARIC	Integrated Tariff of the European Communities		IV
	Tarif intégré des Communautés européennes		
	Integrierter Zolltarif der Europäischen Gemeinschaften		
	Geïntegreerd tarief van de Europese Gemeenschappen		
TDMA	Time Division Multiple Access		VI
	Accès multiple par répartition dans le temps		
	Zeitmultiplexzugriff		
	Meervoudige toegang met tijdverdeling		
THD	Transmitting Heading Device		V
	Dispositif de transmission du cap		
	Steuerkurstransmitter		
	Zendend koersinstrument		

Abbreviation	Stands for	Defined	Used in parts
TTI	Tactical Traffic Information	X	II
	Informations tactiques de trafic		
	Taktische Verkehrsinformationen		
	Tactische verkeersinformatie		
Tx	Transmit		VI
	Transmission		
	Senden		
	Verzenden		
UN/CEFACT	UN Centre for Trade Facilitation and Electronic Business		IV
	Centre des Nations unies pour la facilitation du commerce et les transactions électroniques		
	Zentrum der Vereinten Nationen für Handelserleichterungen und elektronische Geschäftsprozesse		
	Centrum van de Verenigde Naties voor de bevordering van handel en elektronisch zakendoen		
UN/EDIFACT	UN Electronic data interchange for administration, commerce and transport	X	IV
	Échange de données informatisé pour l'administration, le commerce et le transport		
	Regeln der Vereinten Nation für den elektronischen Datenaustausch in Verwaltung, Handel und Verkehr		
	VN-normen inzake elektronische gegevensuitwisseling voor overheid, handel en vervoer		
UN/LOCODE	See LOCODE		IV
	Voir LOCODE		
	Siehe LOCODE		
	Zie LOCODE		
UNDG	United Nations dangerous goods (number)		IV
	Numéro des Nations unies pour les marchandises dangereuses		
	Empfehlungen der Vereinten Nationen für gefährliche Güter (Nummer)		
	VN-nummer voor gevaarlijke goederen		

Abbreviation	Stands for	Defined	Used in parts
UNECE	United Nations Economic Commission for Europe		
CEE-ONU	Commission économique pour l'Europe de l'ONU		
UNECE	Wirtschaftskommission der Vereinten Nationen für Europa		IV, VI
VN-ECE	Economische Commissie van de Verenigde Naties voor Europa		
UNTDID	United Nations trade data interchange directory Répertoire des Nations unies pour l'échange de données commerciales Verzeichnis der Vereinten Nationen für den Austausch von Handelsdaten VN-directory voor het uitwisselen van handelsgegevens		IV
URL	Uniform resource locator (Internet address) Localisateur uniforme de ressource (Adresse Internet) Uniform resource locator (Internetadresse) Uniform resource locator (internetadres)		III
UTC	Universal Time Coordinated Temps universel coordonné Weltzeit Gecoördineerde universele tijd		II, VI
VDL	VHF Data Link Liaison de données VHF UKW-Datenverbindung VHF-dataverbinding		V, VI
VDM	AIS VHF data-link message Message de liaison de données AIS VHF AIS UKW-Datenfunkmeldung AIS VHF-dataverbindingsbericht		V
VDO	AIS VHF data-link own-vessel report Rapport de liaison de données AIS VHF du bateau porteur AIS UKW-Datenübertragungsmeldung des eigenen Schiffs AIS VHF-dataverbindingsmelding eigen schip		V

Abbreviation	Stands for	Defined	Used in parts
VHF	Very High Frequency		
VHF	Très hautes fréquences		II, III, V, VI
UKW	Ultrakurzwele		
VHF	Zeer hoge frequentie		
VRM	Variable Range Marker		
VRM	Repère de distance variable	X	I, V
VEM	Variabler Entfernungs-messring		
VRM	Variabele afstandsmeetring		
VTM	Vessel traffic management		
	Gestion du trafic fluvial	X	II, IV
	Schiffsverkehrsmanagement		
	Scheepvaartverkeersmanagement		
VTS	Vessel Traffic Services		
	Services de gestion de la navigation	X	II, IV
	Schiffsverkehrsdienste		
	Scheepvaartverkeersbegeleidingsdiensten		
VTT	Vessel Tracking and Tracing		
	Suivi et localisation des bateaux	X	I, II, V
	Schiffsverfolgung und Aufspürung		
	Tracking en tracing van schepen		
WCO	World Customs Organisation		
OMD	Organisation mondiale des douanes		IV
WZO	Weltzollorganisation		
WCO	Werelddouaneorganisatie		
WERM	Weather Related Message		
	Avis météorologique		III
	Wettermeldung		
	Bericht met betrekking tot het weer		
WRM	Water Related Message		
	Message relatif aux hauteurs d'eau		III
	Wasserstandsmeldung		
	Bericht met betrekking tot de waterstand		

Abbreviation	Stands for	Defined	Used in parts
WGS 84	World Geodetic System (as defined in 1984) Système géodésique mondial (de 1984) Weltweites geodätisches System (von 1984) Wereldgeodesiesysteem (van 1984)	X	I
WSDL	Web Services Description Language Langage de description de services web Beschreibungssprache für Netzwerkdienste Taal voor het beschrijven van webdiensten	X	III
XML	Extensible markup language Langage de balisage extensible Erweiterte Auszeichnungssprache Uitbreidbare opmaaktaal		II, III, IV
XSD	XML Schema Definition Définition de schéma XML Definition des XML-Schemas XML-schemadefinitie		III, IV

CHAPTER 2

DEFINITIONS

In the table below, each term is given in the four languages: English, French, German and Dutch.. The terms are ordered following the English language.

Term	Definitions	Source	Used in parts
Acronym			
Acronyme			
Akronym	6-character-code of the feature/of the attribute.	REF#IHO-S57	I
Acroniem			
Actor			
Acteur	Transforms an electrical quantity into another physical quantity (e.g. optical). An actor is the opposite of a sensor.		I
Aktor			
Actor			
	European Agreement concerning the International Carriage of Dangerous Goods by Inland Waterways.		
	In the context of this agreement, a code aiming to identify the dangerous goods is used.	REF#EC-200868	
ADN	Its structure varies between dry cargo vessels and tank vessels. For dry cargo vessels, it consists of a UN number, the name of the substance (in accordance with table A of part 3 of ADN), the class, the danger classification code, the packing group and the hazard Identification placard (label). For tankers, it consists of UN number, name of substance (in accordance with table C of part 3 of ADN), the class and the packing group.	or REF#CCNR-2009II20	II, IV
Agent	Any person mandated or authorised to act for or to supply information on behalf of the (transport) operator of the vessel.		IV
Alarm			
Alarme	High-priority alert. Condition requiring immediate attention and action by the bridge team, to maintain the safe navigation of the vessel.		I
Alarm			
Alarm			

Term	Definitions	Source	Used in parts
All information density Densité maximale d'information Höchstinformationsdichte Maximale informatiedichtheid	Maximum amount of SENC information. Here, in addition to the standard display (Standard Information Density), all other objects are also displayed, individually on demand. (Synonym: all display.)		I
Attribute Attribut Attribut Attribuut	Defined characteristic of an entity (e.g. the category of a light, the sector limits, the light characteristics, etc.) Definitions for diverse attributes may be derived from the Feature Catalogue for IENCs (Annex 1).	REF#IHO-S57	I
Aid to Navigation Aide à la navigation Navigationshilfe Navigatiehulpmiddel	Navigational aid (also known as Aids to Navigation, or AtoN) is a marker which provides support during navigation. Such aids include markings for lighthouses, buoys, fog signals, and day beacons.		I, II, V, VI
Automatic Identification System Système d'identification automatique Automatisches Identifizierungssystem Automatisch identificatiesysteem	On-board equipment allowing automatic identification of ships for enhanced ship monitoring as well as voyage data recording and other functions. The automatic identification system shall comply with the technical and performance standards laid down in Chapter V of the SOLAS Convention (Safety of Life at Sea).	REF#EC-200259	I, II, V, VI
Barge Barge Schubleichter Duwbak	Vessel that has no propulsion of its own.		IV
Bathymetric IENC CENI bathymétrique Bathymetrische IENC Bathymetrische IENC	S-57 based product in addition to the already existing products (ENC, IENC). The content of bathymetric ENCs is limited to the bathymetry data only.		I

Term	Definitions	Source	Used in parts
Blue cones Cônes bleus Blaue Kegel Blauwe kegels	Signals that inland vessels carrying out transport operations involving dangerous substances are required to show pursuant to the European Agreement concerning the International Carriage of Dangerous Goods by Inland Waterways (ADN), namely one, two or three blue cones by day and one, two or three blue lights at night.		IV
Boatmaster Conducteur Schiffsführer Schipper	Person on board of the vessel being in command and having the authority to take all decisions pertaining to navigation and vessel management. (Synonyms: shipmaster.)		IV
Cargo Cargaison Ladung Lading	Any goods, wares, merchandise and articles carried on a ship. So ship carries cargo consisting of one or more consignments (with the necessary equipment) each consisting of one or more goods items.		IV
Carrier Transporteur Beförderer Vervoerder	Person responsible for the carriage of goods, either directly or using a third party. (Synonym: transport operator)		IV
Cell Cellule Zelle Cel	Geographical area containing IENC or bathymetric IENC data. (Synonym: chart cell.)	REF#IHO-S57	I
CIE colour calibration Calibrage des couleurs de la CIE CIE-Farbenkalibrierung CIE-kleurenkalibratie	Procedure to confirm that the colour specified in IHO S-52 is correctly reproduced on the ECDIS display.	REF#IHO-S52	I
Class B SO/CS	Class B mobile stations using either "carrier-sense time division multiple access" technique (CSTDMA or CS), or "Self-organising time division multiple access" technique (SOTDMA or SO)		II
Code	Character string used as an abbreviated means of recording or identifying information to represent or identify information using a specific symbolic form that can be recognised by a computer.		IV

Term	Definitions	Source	Used in parts
Common access reference Référence commune d'accès Einheitliche Zugangsreferenz Gemeenschappelijke toegangsreferentie	Common key to relate all subsequent transfers of data to the same business case or file (Data Element 0068 TDED). The common access reference shall be regarded as a common denominator ¹ linking through a unique number documents, electronic messages and other communications with the same objective and characteristics.		IV
Competent Authority for RIS Autorité compétente en matière de SIF Zuständige RIS-Behörde Bevoegde instantie voor RIS	Authority designated by the Member State for the RIS application and for the international exchange of data.		II
Consignee Destinataire Empfänger Ontvanger	Party such as mentioned in the transport document by whom the goods, cargo or containers are to be received.		IV
Consignment Chargement Sendung Zending	Separate identifiable number of goods transported from one consignor (port of loading) to one consignee (port of discharge) and identified and specified in one single transport document. A container as equipment shall in this context be seen as a separate identifiable packing unit for which separate bookings are done and as such shall be considered a single consignment.		IV
Consignor Expéditeur Absender Verzender	Merchant by whom, in whose name or on whose behalf a contract of carriage of goods has been concluded with a carrier or any party by whom, in whose name or on whose behalf the goods are actually delivered to the consignee in relation to the contract of carriage. (Synonyms: shipper, cargo sender.)		IV

¹ The common denominator means an attribute that is common to all members of a category.

Term	Definitions	Source	Used in parts
Container	Item of equipment for transport purposes with the following characteristics:		
Conteneur	a) a permanent character and accordingly strong enough to be suitable for repeated use;		
Container	b) specially designed to facilitate the carriage of goods, by one or more modes and means of transport;		IV
Container	c) fitted with devices permitting its ready handling, particularly from one mode of transport to another;		
Container	d) so designed as to be easy to fill and to empty.		
	The term container includes neither vehicles nor conventional packing.		
Container identification	Code providing information for identification a specific container.		
Identification du conteneur	The code is based on ISO 6346, chapter 3 (Annex A) dated 1995. It is composed of four parts, the owner code (3 letters), the equipment category (1 letter), a serial number (6 numerals) and a check digit (one numeral).	REF#ISO 6346-a	IV
Identifizierung von Containern	This code is used worldwide on all freight containers for general application, for example in documentation, control and communications (including automatic data processing systems), as well as for display on the containers themselves		
Containeridentificatie			
Container size and type	Code providing information for identification and marking of freight containers.		
Dimensions et types de conteneurs	The code is based on ISO 6346, chapter 4 (Annex D and E) dated December 1995. It contains two attributes, one for container size (consisting of two alphanumeric characters: first for length, second for combination of height and width) and another one for container type (consisting of two alphanumeric characters).	REF#ISO-6346-b	IV
Containergrößen und Containertypen			
Containerafmetingen en containertypes	The size type codes are displayed on the containers and as such shall be used in the electronic reporting whenever available from other exchanged information e.g. during the booking. Size type codes shall be used as a whole i.e. the information shall not be broken into its component parts (ISO 6346 : 1995)		

Term	Definitions	Source	Used in parts
	Following categories, referred to in the relevant international instruments as defined in Directive 2002/59/EC of the European Parliament and of the Council:		
Dangerous goods	a) goods classified in the UNDG Code,		
Marchandises dangereuses	b) goods classified in the ADN Code,		
Gefährliche Güter	c) goods classified in the IMDG Code,	REF#EC-200259	IV
Gevaarlijke goederen	d) dangerous liquid substances listed in the IBC Code,		
	e) liquefied gases listed in the IGC Code,		
	f) solids referred to in Appendix B of the BC Code.		
Data			
Données	Collection of values (e.g. output from a sensor) that can be processed.		I
Daten			
Gegevens			
Data element			
Élément de données	Unit of data which, in a certain context, is considered indivisible and for which the identification, description and value representation has been specified.		IV
Datenelement			
Data-element			
Datum		Set of parameters specifying the reference surface, or the reference coordinate system, used for geodetic control in the calculation of coordinates of points on the earth. Commonly datums are defined as horizontal and vertical datum separately. For the practical use of the datum it is necessary to have one or more well distinctive points with coordinates given in that datum.	
Référentiel géodésique	REF#IHO-S52		I
Datum			
Data	The horizontal datum is a set of parameters specifying the reference for horizontal geodetic control, commonly the dimensions and the location of a reference ellipsoid. (The horizontal datum must be compliant with WGS 84.)		
	The vertical datum is a surface to which elevations and/or depths (soundings and tide heights) are referred. For elevations, commonly a level (equipotential) surface, e.g. the “mean sea level” is used as reference or for depths in many cases “low water”.		

Term	Definitions	Source	Used in parts
Deadweight tonnage			
Port en lourd			
Tragfähigkeit in Tonnen	Maximum displacement of a ship after deduction of the weight of the ship.		IV
Tondraagvermogen			
Displacement ton			
Tonne de déplacement	Unit for measuring the displacement of ships equal to 35 ft ³ ; this is approximately equal to the volume of a long ton (1016,06 kg) of sea water.		IV
Verdrängungstonne			
Scheepsgewicht			
Display			
Affichage	Visualised information on a screen		I
Anzeige			
Weergave			
Display base	Minimum information density, i.e. the amount of SENC information that is presented and which cannot be reduced by the user, consisting of information that is required at all times in all geographic areas and under all circumstances.	REF#IMO- MSC232	I
Affichage de base			
Basisanzeige			
Basisweergave			
Display scale			
Échelle d'affichage	Ratio between a distance on the display and a distance on the ground, normalised and expressed as a ratio, e.g. 1:10 000.	REF#IHO-S52	I
Anzeige-maßstab			
Schaal van het beeld			
ECDIS	Electronic Chart Display and Information System means a navigation information system which, with adequate back-up arrangements, can be accepted as complying with the up-to-date chart required by regulations V/19 and V/27 of the 1974 SOLAS Convention, as amended, by displaying selected information from a SENC with positional information from navigation sensors to assist the boatmaster in route planning and route monitoring, and if required display additional navigation-related information.	REF#IMO- MSC232	I, V, VI

Term	Definitions	Source	Used in parts
Edge	Very broad term to describe the data, software, and electronic system, capable of displaying chart information. An electronic chart may or may not be equivalent to the paper chart required by the SOLAS Convention.	REF#IHO-S57	I
Arête			
Kante			
Rand			
EDI number	Electronic address of the sender or receiver of a message (e.g. the sender and receiver of the cargo). This may be an email address, an agreed identifier or e.g. a number of the European Article Numbering Association (EAN number).		IV
Numéro EDI			
EDI-Nummer			
EDI-nummer			
Electronic chart	Very broad term to describe the data, software, and electronic system, capable of displaying chart information. An electronic chart may or may not be equivalent to the paper chart required by the SOLAS Convention.	REF#IMO- MSC232	I
Carte électronique			
Elektronische Karte			
Elektronische kaart			
Electronic data interchange	Transfer of structured data by agreed standards from applications on the computer of one party to applications on the computer of another party by electronic means.		IV
Échange de données informatisé			
Elektronischer Datenaustausch			
Elektronische gegevensuitwisseling			
ENC	The data base, standardised as to content, structure and format, issued for use with ECDIS on the authority of government authorised hydrographic offices. The ENC contains all the chart information necessary for safe navigation and may contain supplementary information in addition to that contained in the paper chart (e.g. sailing directions) which may be considered necessary for safe navigation.	REF#IMO- MSC232	I
CEN			
ENC			
ENC			

Term	Definitions	Source	Used in parts
ENC cell Cellule de la CEN ENC-Zelle ENC-cel	Geographic division of ENC data for distributing purposes.	REF#IEC-200259	I
Unique European vessel identification number Numéro européen unique d'identification des bateaux Einheitliche Europäische Schiffsnummer Uniek Europees scheepsidentificatienummer	It is assigned in accordance with REF#CESNI-ESTRIN-1 which is referenced in the legal frameworks of the EU and the CCNR. It aims at assigning a permanent number to each vessel for identifying purposes. The Member States of the European Union or the CCNR are the authorities responsible for ENI. Competent authorities keep a register. They send the ENI to the European Hull Database (EHDB), as part of the minimum dataset for the identification of a vessel. The ENI consists of eight Arabic numerals. The first three digits are the code of the assigning competent authority. The next five digits are a serial number.	REF#CESNI-ESTRIN-1	II, IV, VI
Enumeration Énumération Enumeration Enumeratie	Specific quality or quantity assigned to an attribute (e.g. 'leading light', the limiting angles, the code specifying the light's colour – see attribute).		I
Fairway section code Code de section de chenal Code des Wasserstraßenabschnitts Vaarwegsectiecode	Waterway network is divided into sections. A section may be whole rivers and canals over several 100 km or small sections. Each section has a fairway section code consisting of a 5 digit alphanumerical code. These codes are provided and managed by national administrations of waterways. The position of a location inside a section may be given by hectometre or by the name (code) of a terminal or passage point.		IV

Term	Definitions	Source	Used in parts
	Geographical, hydrological and administrative information regarding the waterway (fairway) that are used by boatmasters and fleet managers to plan, execute and monitor a voyage.		
Fairway Information Services	FIS provide dynamic information (such as water levels, water level forecasts) as well as static information (such as operating times of locks and bridges) regarding the use and status of the inland waterway infrastructure, and thereby support tactical and strategic navigation decisions.		
Service d'information sur les chenaux			
Wasserstraßeninformationsdienste	Traditional means to supply FIS include visual aids to navigation, notices to skippers published on paper, provided by broadcast and by fixed telephone on locks. The mobile phone has added new possibilities of voice and data communication, but cellular network is not available in all places and at all times. Tailor-made FIS for the waterways can be supplied by radiotelephone service on inland waterways, Internet service or electronic navigational chart service, such as the Inland Electronic Chart Display and Information System (Inland ECDIS) with Inland Electronic Navigational Chart (IENC).		III
Vaarweginformatiediensten			
Feature	Identifiable set of information. A feature may have attributes and may be related to other features.		
Objet	A digital representation of all or a part of an entity by its characteristics (attributes), geometry, and (optionally) relationships to other features (e.g. the digital description of a light sector specifying, amongst others, sector limits, colour of the light, visibility range, etc., and a link to a light tower, if any). Definitions for diverse features may be derived from the Feature Catalogue for IENCs (Annex 1).	REF#IHO-S52	I
Feature			
Object			
Feature catalogue			
Catalogue d'objets	Comprehensive list of currently identified features, attributes and enumerations which are allowed for use in IENCs.	Annex 1, appendix 1	I
Feature-Katalog			
Objectencatalogus			

Term	Definitions	Source	Used in parts
File			
Fichier	Identified set of S-57 records (REF#IHO-S57) gathered together for a specific purpose. The file content and structure must be defined by a product specification.	REF#IHO-S52	I
Datei			
Bestand			
Fleet manager			
Gestionnaire de flotte	Person planning and observing the actual (navigational) status of a number of vessels moving or working under one command or ownership.		III
Flottenmanager			
Vlootmanager			
Global Navigation Satellite System			
Système mondial de navigation par satellite	A system that uses satellites to provide autonomous geo-spatial positioning.		I, II, V, VI
Globales Satellitennavigationssystem			
Wereldwijd satellit navigatie-systeem			
Goods			
Marchandises	Movable property, merchandise or wares.		IV
Güter			
Goederen			
Goods item			
Article de marchandises	Whole or part of the cargo (consignment) received from the shipper, including any packaging material such as pallets supplied by the shipper.		IV
Güterposition			
Goederen			
Gross tonnage			
Tonnage brut	Measure of the overall size of a vessel determined in accordance with the provisions of the international convention on measurement of vessels, usually expressed in register ton.		IV
Bruttoreaumzahl			
Brutotonnage			

Term	Definitions	Source	Used in parts
Gross weight Poids brut Bruttogewicht Brutogewicht	Weight (mass) of goods including packing, but excluding the carriers equipment expressed in whole kilograms.		IV
Handling instructions Instructions de manutention Umschlag-anweisungen Behandelings-instructies	Handling instruction description code is used to describe handling instructions for the tasks to be executed in a port to facilitate the handling of the vessel and establishing handling tariffs. It has been introduced through the use of UN/EDIFACT in the IFTDGN message (data element 4079). It is composed of 3 alphanumerical digits.		IV
Heading Cap Vorausrichtung (heading) Vaarrichting (koers)	Direction in which the longitudinal axis of a craft is pointed, usually expressed as an angular distance from north clockwise through 360 degrees. The technical term "heading" is understood to be heading information provided by a Transmitting Heading Device.	REF#IHO-S52	I
Head-up display Affichage cap en haut Voraus-orientierte Anzeige Vooruit georiënteerde weergave	Information shown on the display (radar or ECDIS) is directed so that the vessel's heading is always pointing upward. This orientation corresponds to the visual view from the bridge in direction of the vessel's heading.	REF#IHO-S52	I
Helmsman Timonier Steuermann Stuurman	Person who navigates the vessel, according to the voyage plan instructions of the boatmaster.		II

Term	Definitions	Source	Used in parts
HS Code	Harmonised commodity description and coding system is maintained by WCO and was established through the International Convention on the Harmonised Commodity Description and Coding System which entered into force January 1988. The objectives of this convention are (i) to facilitate international trade and the collection, comparison and analysis of statistics by harmonizing the description, classification and coding of goods in international trade; (ii) to reduce the expenses related to international trade and (iii) to facilitate the standardization of trade documentation and the transmission of data.		IV
Code SH			
HS-Code			
GS-cCode	The HS Code is broken down in 4 hierarchical level, the section code (I to XXI), the chapter (two-digits numerical), the heading (two additional digits for a total of four-digits numerical) and the subheading (two additional digits for a total of six-digits numerical).		
	A subset of the codes used for electronic reporting is maintained by CESNI. The HS classification is further subdivided at European Union level into a classification called Combined Nomenclature (CN).		
Human Machine Interface	Part of the machine that handles the human-machine interaction. The engineering of the human-machine interfaces is enhanced by considering ergonomics (human factors). There are many ways to develop human-machine interface (HMI) screens for machine and process automation applications. Guidelines, standards, and handbooks covering HMI design include those published by ISA, ASM, ISO, and NUREG.		I
Interface homme-machine			
Mensch-Maschine-Schnittstelle			
Mens/machine-interface	(Synonym: (graphical) user interface.)		
IEC			
CEI	International Electrotechnical Commission: an international (non-governmental) organisation which produces world standards for electrical and	REF#IHO-S52	I
IEC	electronical engineering with the objective of facilitating international trade.		
IEC			

Term	Definitions	Source	Used in parts
IHO OHI IHO IHO	International Hydrographic Organization: coordinates the activities of national hydrographic offices; promotes standards and provides advice to developing countries in the fields of hydrographic surveying and production of nautical charts and publications.	REF#IHO-S52	I, V
IHO Geospatial Information registry Base de registres de l'OHI des informations géospatiales IHO-Registratur für Geoinformation IHO-registry voor georuimtelijke informatie	A registry is the information system on which a register is maintained. In the case of S-100, IHO hosts a registry that provides a facility to store various registers of hydrographic-related information.	REF#IHO-S100	I
IMDG Code Code IMDG IMDG-Code IMDG-Code	International maritime dangerous goods code is maintained by IMO since 18 May 1965. It governs the vast majority of shipments of hazardous material by water. The code is recommended to governments for adoption as the basis for national regulations in conjunction with the SOLAS convention. This code is based on the UN Recommendations on the transport of dangerous goods (UNDG). The code is composed of 2-digits numerical code, 1 digit for the class and 1 digit for the division. For inland shipping the IMO code may be used as this code is often already known, where necessary an ADN corresponding with the IMDG code shall be inserted.		IV
IMO OMI IMO IMO	International Maritime Organization: formerly called IMCO, IMO is the specialised agency of the United Nations responsible for maritime safety, efficiency of navigation and prevention of marine pollution from vessels.	REF#IHO-S52	I, IV, V, VI

Term	Definitions	Source	Used in parts
IMO No No OMI IMO-Nummer IMO-nr.	<p>IMO (ship identification) number</p> <p>The IMO resolution A.600(15), SOLAS Chapter XI, regulation 3 aims at assigning a permanent number ship identification number to each (seagoing) ship for identifying purposes.</p> <p>The responsible agency for this number is IMO but it is issued and maintained by Information Handling Service Maritime & Trade (IHS M&T).</p> <p>The IMO number consists of 7 digits.</p>		IV
Information Information Informationen Informatie	Processed data		I
Information Mode Mode information Informationsmodus Informatiemodus	Use of the Inland ECDIS for information purposes only without overlaid radar image.	Part I, Chapter 1	I
Inland AIS AIS Intérieur Inland AIS Inland AIS	<p>AIS for the use in inland navigation and interoperable with (maritime) AIS-technically enabled by amendments and extensions to the (maritime) AIS.</p> <p>'Automatic Identification System (AIS)' an automatic communication and identification system intended to improve the safety of navigation by assisting in the efficient operation of vessel traffic services (VTS), ship reporting, and in efficient ship-to-ship and ship-to-shore operations.</p>	REF#EC-200259	I, II
Inland AIS mobile station Station AIS Intérieur mobile Inland-AIS-Mobilestation Mobiel Inland AIS-station	Inland AIS station installed on board of a craft or on a floating object.		II

Term	Definitions	Source	Used in parts
Inland AIS shore station			
Station AIS Intérieur terrestre			
Inland-AIS-Landstation	Inland AIS station installed on shore.		II
Inland AIS-basisstation			
Inland AIS station			
Station AIS Intérieur			
Inland AIS Gerät	Equipment that has Inland AIS functionality.		II
Inland AIS-station			
Inland ECDIS			
ECDIS Intérieur	Electronic Chart Display and Information System for inland navigation, displaying selected information from a SENC and optionally, information from other navigation sensors.	Part I, Chapter 1	I, II, V
Inland ECDIS			
Inland ECDIS			
Inland Electronic Navigational Chart	Database, standardised as to content, structure and format, for use with inland electronic chart display and information systems operated on-board of vessels transiting inland waterways. An IENC is issued by, or on the authority of, a competent government agency, and conforms to standards initially developed by the International Hydrographic Organization (IHO) and refined by the IENC Harmonization Group. An IENC contains all the chart information necessary for safe navigation on inland waterways and may contain supplementary information in addition to that contained in the paper chart (e.g. sailing directions, machine-readable operating schedules, etc.) which may be considered necessary for safe navigation and voyage planning.		I
Carte électronique de navigation intérieure			
Elektronische Navigationskarte für die Binnenschifffahrt			
Elektronische navigatiekaart voor de binnenvaart			
Inland ENC domain			
Domaine des CENI	Domain within the IHO Geospatial Information Registry dedicated for IENC – related entries.	REF#IHO-S100	I
Inland ENC Domain			
Inland ENC-domein			

Term	Definitions	Source	Used in parts
Integrated display			
Affichage intégré			
Integrierte Darstellung	Head-up, relative-motion picture consisting of the SENC overlaid with the radar-image with matching scale, offset and orientation.		I
Geïntegreerde weergave			
ISRS Location Code			
Code de localisation ISRS	20-digit alphanumeric code used to establish a unique and standardised relation between objects in River Information Services		I, II, III, IV
ISRS-Ortscode			
ISRS-locatiecode			
Location	Any named geographical place, such as a port, an inland freight terminal, an airport, a container freight station, a terminal or any other place where customs clearance or regular receipt or delivery of goods can take place, with permanent facilities used for goods movements associated with international trade or transport and used frequently for those purposes. The location shall be recognised as such by a competent national body.		IV
Lieu			
Ort			
Locatie			
Look-up table			
Table de recherche	Table giving symbology instructions to link SENC objects to point, line or area symbolization and providing display priority, radar priority, IMO category and optional viewing group.	REF#IHO-S52	I
Nachschlage-tafel			
Opzoektabel			

Term	Definitions	Source	Used in parts
Maritime Mobile Service Identity			
Identité dans le Service Mobile Maritime			
Seemobildienst-kennung	Series of nine digits which are transmitted over the radio path in order to uniquely identify vessel, stations, shore stations and group calls.		II, VI
Identiteitsnummer voor maritieme mobiele diensten			
Means of transport			
Moyen de transport			
Transportmittel	Type of vehicle used for the transport of goods such as barge, truck, vessel or train.		IV
Vervoermiddel			
Message implementation manual			
Manuel de mise en œuvre de messages			
Implementierungs-handbuch	Manual that describes in detail how a certain standard message will be implemented and which segments, data elements, codes and references will be used and how. In other contexts, the term "Message implementation guide" could be used and should be considered equivalent.		IV
Handleiding voor de toepassing van berichten			
Metric ton			
Tonne métrique			
Tonne	Unit of weight equivalent to 1000 kg.		IV
Metrische ton			
Mode of transport			
Mode de transport			
Verkehrsträger	Method of transport used for the conveyance of goods e.g. by rail, by road, by sea, by inland waterways.		IV
Vervoerswijze			

Term	Definitions	Source	Used in parts
Monitor			
Moniteur	Physical device for display of information, including screen, power supply, connectors (physical interfaces)		I
Monitor			
Monitor			
Nature of cargo	Cargo type classification code is a numeric code system used to specify the classification of a type of cargo as transported to facilitate identification, recording, handling, and establishing tariffs.		IV
Nature de la cargaison			
Art der Ladung		This code is composed of 2 numeric digits and was first introduced through the use of UN/EDIFACT format for the IFTDGN message	
Aard van de lading			
Navigation mode			
Mode navigation	se of Inland ECDIS equipment with radar overlay for navigating a craft.	Part I, Chapter 1	I
Navigationsmodus			
Navigatiemodus			
Navigation information			
Informations relatives à la navigation	Information provided to the boatmaster on board to support in on-board decision-making.		II
Nautische Informationen			
Navigatie-informatie			
Next port of call			
Port d'escale suivant	Consecutive place (port of call) where a ship will arrive after having made a voyage. The term is used, by the boatmaster only, to indicate the subsequent competent authority in accordance with the applicable regulations.		IV
Nächster Anlaufhafen			
Volgende aanloophaven			
North-up display			
Affichage nord en haut	Information shown on the display with the north direction upward.	REF#IHO-S52	I
Nordorientierte Anzeige			
Weergave met noorden boven			

Term	Definitions	Source	Used in parts
NST 2007	Standard goods classification for transport statistics (to be used from 2007 onwards), based on Commission Regulation (EC) 1304/2007 is maintained by Eurostat, the Statistical Office of the European Union. This code consists of a two-digits numerical describing high-level types of transported goods for statistical purposes.	REF#EC-20071304	IV
Other navigational information Autres informations de navigation Andere nautische Informationen Overige navigatie-informatie	Navigational Information not contained in the SENC, that may be displayed by an ECDIS, such as radar or AIS information.	REF#IHO-S52	I
Own vessel Bateau porteur Eigenes Schiff Eigen vaartuig	Vessel upon which an ECDIS is operating.	REF#IHO-S52	I
Own vessel's safety contour Isobathe de sécurité du bateau porteur Schiffseigene Sicherheitskontur Veiligheidscontour van het eigen vaartuig	Contour related to the own vessel selected by the boatmaster from the contours provided for in the SENC, to be used by ECDIS to distinguish on the display between the safe and the unsafe water, and for generating anti-grounding alarms.	REF#IHO-S52	I
Package type Type d'emballage Art der Verpackung Verpakkingstype	Code for types of package and packing materials to describe the appearance of goods as presented for transport to facilitate identification, recording, handling, and establishing handling tariffs. It is based on UNECE recommendation 21, dated August 1994. The package types have both an alphabetical code (2 letters) and a numeric code (2 digits) that can be used. Only the alphabetical code is used for the purpose of electronic ship reporting.	REF#UNECE-R21	IV

Term	Definitions	Source	Used in parts
Passage point Point de passage Durchfahrtpunkt Controlepunt	Defined distinguishable spot which serves as a marker to determine parts of a voyage of a vessel and triggering a certain action. It may take the form a virtual line perpendicular on the fairway axis running from side to side of the fairway.		IV
Performance standard for ECDIS Standard de performance pour l'ECDIS Leistungsstandard für ECDIS Prestatienorm voor ECDIS	Standard developed under the authority of IMO to describe the minimum performance requirements for navigational devices and other fittings required by the SOLAS Convention, included in MSC.232(82), as adopted by IMO on 5 December 2006.	REF#IHO-S52	I
Pick report (feature report) Rapport d'objet (fenêtre objet) Featurebericht Pick-report (Objectbericht)	Result of querying a displayed point-symbol, line or area for further information from the data base which is not represented by the symbol.	REF#IHO-S52	I
Port of call Port d'escale Anlaufhafen Aanloophaven	Place where a vessel actually drops anchor, moors or otherwise comes to rest for a certain period of time to execute any necessary operations related to ship, cargo or crew.		IV
Presentation library for ECDIS Bibliothèque de présentation pour l'ECDIS Darstellungs-bibliothek für ECDIS Weergave-bibliotheek voor ECDIS	Set of mostly digital specifications, composed of symbol libraries, colour schemes, look-up tables and rules, linking every feature and attribute of the SENC to the appropriate presentation of the ECDIS display. Published by IHO as Annex A, Special Publication No 52 (S-52).	REF#IHO-S52	I

Term	Definitions	Source	Used in parts
Product specification Spécification de produit Produkt- beschreibung Productspecificatie	Defined subset of the entire specification combined with rules, tailored to the intended usage of the transfer data. (The ENC Product specification specifies the content, structure and other mandatory aspects of an ENC.)	REF#IHO-S52	I
Purpose of call Objet de l'escale Zweck des Anlaufens Doel van de aanloop	Conveyance call purpose description code is a numeric code system used to describe the purpose of the call of the vessel to facilitate identification and recording. This code is composed of 2 numeric digits and was first introduced through the use of UN/EDIFACT in the IFTDMG message.		IV
Qualifier Qualifiant Vorgabewert Kwalificerend element	Data element whose value is expressed as a code that gives specific meaning to the function of another data element or a segment.		IV
Radar	Radio Detecting and Ranging		V
Range Portée Entfernungsbereich Bereik	Distance from the outer most fixed range ring that is completely shown, to the center of the radar picture, when the radar picture is centered.	REF#IEC-S52	I
Rate of turn Vitesse de giration Wende- geschwindigkeit Draaisnelheid	Measure of how fast a craft is turning. This is displayed in the rate of turn indicator. The unit of measure is degrees / min.	REF#CESNI- ESTRIN-5a	I
Reference number Numéro de référence Referenznummer Referentienummer	Number that serves to refer to or mention a relation or where applicable a restriction.		IV

Term	Definitions	Source	Used in parts
Register ton			
Tonneau	Unit of internal capacity of ships equal to 100 cubic feet (2831,7 m ³).		IV
Registertonne			
Registerton			
Relative motion display			
Affichage en mouvement relative	Chart information and radar targets moving relative to the vessel position fixed on the screen.	REF#IHO-S52	I
Anzeige der relativen Bewegung			
Relatief tot het vaartuig bewegende weergave			
RIS application			
Mise en œuvre des SIF	Provision of river information services through dedicated systems.		II
RIS-Anwendung			
RIS-applicatie			
RIS operator			
Opérateur SIF	Person performing one or more tasks related to the provision of RIS services.		II
RIS-Betriebspersonal			
RIS-operator			
RIS users	All different user groups including boatmasters, RIS operators, lock and/or bridge operators, waterway authorities, port and terminal operators, operators in calamity centres of emergency services, fleet managers, cargo shippers and freight brokers.		II
Usagers des SIF			
RIS-Nutzer			
RIS-gebruikers			

Term	Definitions	Source	Used in parts
River Information Services Services d'information fluviale Binnenschiffahrts- informationsdienste Rivierinformatie- diensten	Harmonised information services to support traffic and transport management in inland navigation, including, wherever technically feasible, interfaces with other transport modes. RIS do not deal with internal commercial activities between one or more of the involved companies, but are open for interfacing with commercial activities. RIS comprise services such as fairway information, traffic information, traffic management, calamity abatement support, information for transport management, statistics and customs services and waterway charges and port dues.		II
Route planning Planification de l'itinéraire Fahrtroutenplanung Routeplanung	ECDIS function in which the area needed to study the intended route is displayed, to select the intended track, and to mark the track, its way points and navigational notes.	REF#IMO- MSC232	I
SCAMIN	Minimum scale at which the feature may be used e.g. for ECDIS presentation.	REF#IHO-S57	I
Screen Ecran Bildschirm Scherm	Physical component of a monitor for displaying information		I
Segment	Predefined and identified set of functionally related data elements values which are identified by their sequential positions within the set. A segment starts with a segment tag and ends with a segment terminator. It can be a service segment or a user data segment.		IV
Segment code Code de segment Segmentkennung Segmentcode	Code which uniquely identifies each segment as specified in a segment directory.		IV

Term	Definitions	Source	Used in parts
Shipmaster			
Responsable du bateau	See 'Boatmaster'		II, IV
Schiffsführer	(Synonym: boatmaster).		
Scheepsgezagvoerder			
SOAP	'Simple Object Access Protocol' means, as per the standards of World Wide Web Consortium, a messaging protocol specification for exchanging structured information in the implementation of web services in computer networks;		III
Spatial object			
Objet spatial	Object which contains the position and location-related information about real world entities.	REF#IHO-S52	I
Räumliches Objekt			
Ruimtelijk object			
Standard Information Density			
Densité d'information standard	Default amount of SENC information that shall be visible when the chart is displayed when ECDIS is switched on. A screen with Standard Information Density (standard display) is the default state of the Inland ECDIS.		I
Standard-informationsdichte			
Standaard-informatiedichtheid			
Strategic Traffic Information			
Informations stratégiques de trafic	Information affecting the medium and long-term decisions of RIS users. Strategic Traffic Information is used to generate a Strategic Traffic Image.		II
Strategische Verkeersinformatie			
strategische verkeersinformatie			

Term	Definitions	Source	Used in parts
System Electronic Navigational Chart			
Carte électronique de navigation spécifique au système	Internal data base in an Inland ECDIS which results from the transformation of ENC's and their update files and other data added by the boatmaster. It is this data base that is actually accessed by the ECDIS for the display generation and other navigational functions. The SENC may also contain information from other sources.	REF#IHO-S52	I
Systemspezifische Elektronische Navigationskarte			
Systeemspezifieke elektronische navigatiekaart			
Tactical Traffic Information			
Informations tactiques de trafic	Information affecting immediate navigation decisions in the actual traffic situation and the close geographic surroundings. Tactical Traffic Information is used to generate a Tactical Traffic Image.		II
Taktische Verkehrs-informationen			
Tactische verkeersinformatie			
Tag	Unique identifier for a segment or data element.		IV
Terminal code	Further specification of the location of a terminal within the location of the port in the country. It is composed of 5 digits alphanumerical. Each national administration of waterway is responsible for its own data and communicates it to users through the ERDMS. If no terminal code is available, then "00000" is used. It is of the utmost importance that maintenance of the codes is done in such way that maximum stability and consistency is achieved to ensure that no changes are necessary apart from additions and deletions.		IV
Code du terminal			
Terminalcode			
Terminalcode			
Track			
Itinéraire	Path followed or to be followed between one position and another.		II
Strecke			
Traject			

Term	Definitions	Source	Used in parts
Transport notification			
Notification de transport	Announcement of an intended voyage of a ship to a competent authority.		IV
Transportanmeldung Transportkennisgeving			
True motion display			
Affichage en mouvement réel	Display in which the own vessel and each radar target moves with its own true motion, while the position of all charted information remains fixed.	REF#IHO-S52	I
Anzeige der absoluten Bewegung			
Weergave van de ware beweging			
UN/EDIFACT	UN rules for Electronic Data Interchange for Administration, Commerce and Transport. They comprise a set of standards, directories and guidelines for the electronic interchange of structured data, and in particular that related to trade in goods or services between independent computerised information systems. Recommended within the framework of the UN, the rules are approved and published by the UNECE in the UN Trade Data Interchange Directory (UNTDID) and are maintained under agreed procedures.		IV
UN/LOCODE	United Nations location code (or UN code for trade and transport locations) is based on UNECE recommendation 16, dated 1980. It consists in 5 alphanumerical digits. The first two are the UN Country code of the location, followed by a space and 3 alphanumerical digits for a precise location. Optionally, it can be followed by a remark with 45 alphanumerical characters and geographical coordinates (000 N 0000 W, 000 S 00000 E).	REF#UNECE-R16	IV

Term	Definitions	Source	Used in parts
UN Country code Code de pays de l'ONU Ländercode der Vereinten Nationen VN-landcode	International standard codes for the representation of the names of countries is based on the standard ISO 3166-1, issued in 1974. All the countries listed in this standard have two codes, one with two-letters (to be used in principle), and another one with three letters (can be used alternatively).	REF#ISO 3166-1	III, IV
URL	Location of a network resource typically used for internet addresses		III
User-defined settings Configuration utilisateur Benutzer-definierte Einstellungen Gebruikers-instellingen	Possibility to use and store a profile of display and control elements settings.		I
Variable Range Marker Repère de distance variable Variabler Entfernungsmessring Variabele afstandsmeetring	Circle of adjustable diameter and centre in the vessel's own position for measuring distances to other vessels and objects.		I
Vessel Tracking and Tracing Suivi et localisation des bateaux Schiffsverfolgung und -aufspürung Tracking en tracing van schepen	The two following functions: Tracking: maintaining status information of the vessel, such as the current position and characteristics, and - if needed - combined with information on cargo and consignments, Tracing: retrieving of information concerning the whereabouts of the vessel and - if needed - information on cargo, consignments and equipment.	REF#ETSI-303676	I, II

Term	Definitions	Source	Used in parts
Vessel Traffic Management			
Gestion du trafic fluvial	Functional framework of harmonised measures and services to enhance the safety, security, efficiency of shipping and the protection of the marine environment in all navigable waters.		II
Schiffsverkehrsmanagement			
Scheepvaartverkeersmanagement			
Vessel traffic Services	Service, implemented by a competent authority, designed to improve the safety and efficiency of vessel traffic and to protect the environment. The service should have the capability to interact with the traffic and to respond to traffic situations developing in the VTS area.		II, IV
Services de gestion du trafic fluvial			
Schiffsverkehrsdienste			
Scheepvaartverkeersbegeleidingsdiensten	A VTS area is the delineated, formally declared service area of a VTS. A VTS area may be subdivided in sub-areas or sectors.		
Voyage			
Voyage	Journey of a vessel between the port(s) of loading and the first port of discharge of a consignment.		IV
Fahrt			
Reis			
Warning	Alert for a condition requiring immediate attention, but no immediate action by the bridge team. Warnings are presented for precautionary reasons to make the bridge team aware of changed conditions which are not immediately hazardous but may become so if no action is taken.		I
Avertissement			
Warnung			
Waarschuwing			
WGS 84	World Geodetic System from 1984: The geodetic basis for the 'Navigational Satellite Timing and Ranging - Global Positioning System', which enables the surveying of the earth and its entities, developed by the United States Department of Defence. This global geodetic reference system is recommended by IHO for hydrographic and cartographic use.		I, III
WSDL	XML document used to describe the operation of a web service based on the SOAP protocol, in particular the operations (or functionalities) available and the associated message formats.		III

Term	Definitions	Source	Used in parts
XSD	XML document used to define the structure and type of content expected of another XML document. This makes it possible, using appropriate software, to automatically check the conformity of an XML document with an XSD document.		III, IV

CHAPTER 3 REFERENCES

The table below gives all external references that are used in ES-RIS.

#	Document	Used in parts
REF#CCNR-2009II20	CCNR Resolution 2009-II-20 - Abrogation of the ADN - Introduction of ADN on the Rhine	II, IV
REF#CESNI-ESTRIN	ES-TRIN 2025/1	I, V, VI
REF#CESNI-ESTRIN-1	ES-TRIN 2025/1, Annex 1	V
REF#CESNI-ESTRIN-5a	ES-TRIN 2025/1, Annex 3, Section I Models of inland navigation vessel certificates	IV
REF#CESNI-ESTRIN-5a	ES-TRIN 2025/1, Annex 5, Section I Minimum requirements and test conditions for navigational radar installations in inland navigation	I, V, VI
REF#CESNI-ESTRIN-5b	ES-TRIN 2025/1, Annex 5, Section II Minimum requirements and test conditions for rate of turn indicators in inland navigation	I, V, VI
REF#CESNI-ESTRIN-5c	ES-TRIN 2025/1, Annex 5, Section III Requirements for installation and performance tests for navigational radar installations and rate of turn indicators in inland navigation	I, V, VI
REF#EC-200259	Directive 2002/59/EC of the European Parliament and of the Council of 27 June 2002 establishing a Community vessel traffic monitoring and information system and repealing Council Directive 93/75/EEC	I
REF#EC-2004725	Regulation (EC) No 725/2004 of the European Parliament and of the Council of 31 March 2004 on enhancing ship and port facility security	IV
REF#EC-20071304	Commission Regulation (EC) No 1304/2007 of 7 November 2007 amending Council Directive 95/64/EC, Council Regulation (EC) No 1172/98, Regulations (EC) No 91/2003 and (EC) No 1365/2006 of the European Parliament and of the Council with respect to the establishment of NST 2007 as the unique classification for transported goods in certain transport modes	IV
REF#EC-200868	Directive 2008/68/EC of the European Parliament and of the Council of 24 September 2008 on the inland transport of dangerous goods	II, IV
REF#EN-60945	EN 60945 (2002) + corr1 (2010): Marine navigational equipment; General requirements - Methods of testing and required test results	I

#	Document	Used in parts
REF#EN-61162	EN 61162 Maritime navigation and radiocommunication equipment and systems - Digital interfaces	V
REF#EN-61162-1	EN 61162-1 : 2016 Maritime navigation and radiocommunication equipment and systems – Digital interfaces – Part 1: Single talker and multiple listeners	V
REF#EN-61162-2	EN 61162-2 : 1998 Maritime navigation and radiocommunication equipment and systems – Digital interfaces – Part 2: Single talker and multiple listeners, high-speed transmission	V
REF#EN-61162-3	EN 61162-3 : 2014 Maritime navigation and radiocommunication equipment and systems – Digital interfaces – Part 3: Serial data instrument network	V
REF#ETSI-303676	ETSI EN 303 676 (2021) Navigation radar used on inland waterways; Operational, functional and technical requirements	
REF#EU-201065	Directive 2010/65/EU of the European Parliament and of the Council of 20 October 2010 on reporting formalities for ships arriving in and/or departing from ports of the Member States and repealing Directive 2002/6/EC	IV
REF#EU-201490	Commission Directive 2014/90/EU of 23 July 2014 on marine equipment and repealing Council Directive 96/98/EC	II
REF#EUROSTAT-IWTS	Reference Manual on Inland Waterway Transport Statistics	IV
REF#IALA-R0126	Recommendation R0126 of IALA: The use of the automatic identification system (AIS) in marine aids to navigation services (A-126), 2011	II
REF#IALA-R0143	Recommendation R0143 of IALA: Provision of virtual aids to navigation (O-143), 2010 (revised in 2021)	II
REF#IALA-G1081	Guidelines G1081 of IALA: Provision of virtual aids to navigation, 2013 (revised in 2021)	II
REF#IALA-1371	Technical clarifications on ITU-R M.1371 by IALA	II
REF#IEC-60945	IEC 60945 fourth edition 2002-08 Maritime navigation and radiocommunication equipment and systems - General requirements - Methods of testing and required test results	V
REF#IEC-61162	International Standard IEC 61162-Serie, Maritime navigation and radio communication equipment and systems - Digital interfaces:	II
REF#IEC-61162-1	Part 1: Single talker and multiple listeners, 2016;	
REF#IEC-61162-2	Part 2: Single talker and multiple listeners, high speed transmission, 1998.	

#	Document	Used in parts
REF#IEC-61174	IEC-Guideline 61174 ECDIS — Operational and performance requirements, methods of testing and required test results Edition 4.0, 2008	I
REF#IEC-61993 and REF#IEC-61993-2	IEC 61993-2, Maritime navigation and radiocommunication equipment and systems — Automatic Identification systems (AIS) — Part 2: Class A shipborne equipment of the universal automatic identification system (AIS), Operational and performance requirements, methods of test and required test results, 2018	II, VI
REF#IEC-62287	62287-Series, Maritime navigation and radio communication equipment and systems — Class B shipborne equipment of the automatic identification system (AIS), 2017 Part 1: Carrier-sense time division multiple access (CSTDMA) techniques; Part 2: Self-organising time division multiple access (SOTDMA) techniques	II
REF#IEC-62288	IEC 62288 (2021): Maritime navigation and radiocommunication equipment and systems – Presentation of navigation-related information on shipborne navigational displays – General requirements, methods of testing and required test results	V
REF#IEC-62320-2	Maritime navigation and radiocommunication equipment and systems – Automatic identification system (AIS) – Part 2: AIS AtoN Stations – Operational and performance requirements, methods of testing and required test results	II, VI
REF#IEC-62388	IEC 62388 Maritime navigation and radiocommunication equipment and systems – Shipborne radar – Performance requirements, methods of testing and required test results, 2013	I
REF#IEEE-2008754	754-2008 - IEEE Standard for Floating-Point Arithmetic	IV
REF#IHO-S32	IHO Special Publication No S-32 Appendix 1 Glossary of ECDIS-related Terms	I
REF#IHO-S52	IHO Special Publication No S-52 Specifications for Chart Content and Display Aspects of ECDIS Edition 6.1.1, October 2014 with clarifications up to June 2015, with all Appendices and Annexes, including Annex A to former S-52, Appendix 2, “Presentation library”, Edition 4.0.2 (October 2014 with clarifications up to 2017)	I
REF#IHO-S57	IHO Special Publication No S-57 IHO Transfer Standard for Digital Hydrographic Data, Edition 3.1, Supplement No 3, June 2014 with all Appendices and Annexes	I

#	Document	Used in parts
REF#IHO-S58	IHO Special Publication No S-58, ENC Validation Checks, Edition 6.1.0, September 2018	I
REF#IHO-S62	IHO Special Publication No S-62 ENC Producer Codes	I
REF#IHO-S100	Inland domain in the S-100 Registry (IHO)	I
REF#IMO-A1106	IMO Resolution A.1106(29) Revised Guidelines for the Onboard Operational Use of Shipborne Automatic Identification System (AIS), 2015	II
REF#IMO-A915	IMO Resolution A.915(22), Revised Maritime Policy and Requirements for a future Global Navigation Satellite System (GNSS), 2002	II
REF#IMO-MS74	MSC.74(69) Annex 3, Recommendation on Performance Standards for a Ship-borne Automatic Identification System (AIS), 1998	II
REF#IMO-MS232	IMO Resolution MSC.232(82) Revised Performance Standards for Electronic Chart Display and Information Systems (ECDIS) Appendix 3 Navigational elements and parameters, December 2006	I
REF#IMO-SN289	IMO Circular SN.1/Circ.289, Guidance on the use of AIS application-specific messages, 2010	II
REF#IMO-SOLAS	International Convention of Safety Of Life At Sea (SOLAS) by the International Maritime Organisation (IMO), Chapter V Safety of navigation, 1974, as amended	II
REF#ISO-IEC-8211	ISO/IEC 8211 : 1994, Information technology - Specification for a data descriptive file for information interchange	I
REF#ISO-IEC-8859-1	ISO/IEC 8859-1 : 1998, information technology – 8-bit single-byte coded graphic character sets – Part 1: Latin alphabet No. 1	I
REF#ISO-8601	ISO 8601, Data elements and interchange formats - Information interchange - Representation of dates and times	IV
REF#ISO-19107	ISO 19107 : 2003, Geographic information Spatial schema	I
REF#ISO-19125	ISO 19125-1 : 2004, Geographic information - Simple feature access Part 1: Common architecture	I
REF#ISO-19125-s61143	ISO 19125-1 : 2004 definitions referenced in this section, refer to section 6.1.14.3 entitled “Named spatial relationship predicates based on the DE-9IM” in the ISO 19125-1 : 2004 document	I
REF#ISO-3166-1	ISO 3166-1, International Standard for country codes and codes for their subdivisions, codes for countries, issued in 1974, revised in 2020	III, IV
REF#ISO-6346a	ISO 6346, Chapter 3 and Annex A	IV
REF#ISO-6346b	ISO 6346, Chapter 4 and Annexes D and E	IV

#	Document	Used in parts
REF#ISO-9711-1	ISO-9711-1 : 1990, Freight containers - Information related to containers on board vessels Part 1: Bay plan system	IV
REF#ITU-R585	Recommendation by the International Telecommunication Union ITU-R M.585 Assignment and use of identities in the maritime mobile service, 2015	II
REF#ITU-R823	Recommendation ITU-R M.823-2 - technical characteristics of differential transmissions for global navigation satellite systems from maritime radio beacons in the frequency band 283.5-315 khz in region 1 and 285-325 khz in regions 2 and 3	II
REF#ITU-R1371	Recommendation ITU-R M.1371-5 Technical characteristics for a universal shipborne automatic identification system using time division multiple access in the VHF maritime mobile band, 2014	II, V, VI
REF#ITU-R1371a	Recommendation ITU-R M.1371-5, Annex 2, § 3.1.1.4	II
REF#ITU-R1371b	Recommendation ITU-R M.1371-5, Annex 2, § 3.1.3.3.2	II
REF#PIANC-RIS	The World Association for Waterborne Transport Infrastructure (PIANC) Guidelines and Recommendations for River Information Services, 2011	II
REF#RTCM-DGNSS	SC-104 Interface to receive and process differential correction data	VI
REF#RTCM-GNSS	Recommended Standards for Differential GNSS Service, 2010	II
REF#UNECE-R16	UNECE recommendation No 16 - United Nations Code for Trade and Transport Locations	IV
REF#UNECE-R19	UNECE Recommendation No 19 - Code for modes of transport	IV
REF#UNECE-R21	UNECE Recommendation No 21 - Codes for Passengers, Types of Cargo, Packages and Packaging Materials	IV
REF#UNECE-R28	UNECE Recommendation No 28 Codes for Types of Means of Transport, Revision 4.2 (2018)	II

PART I

ELECTRONIC CHART DISPLAY AND INFORMATION SYSTEM FOR INLAND NAVIGATION (INLAND ECDIS)

CHAPTER 1 GENERAL PROVISIONS

Article 1.01 General provisions

1. Electronic Chart Display and Information System for inland navigation (Inland ECDIS) is composed of hardware, software for the operating system and application software.
2. Inland ECDIS aims to contribute to the safety and efficiency of inland shipping.
3. Inland ECDIS can be designed for different modes:
 - a) Information mode

The minimum requirements for Inland ECDIS designed for **information mode**, specified in Part I, Chapter 2, are mandatory on waterways where carriage requirements are enacted by the responsible legislative organs. In other regions they are recommended. This mode can be the fall-back mode for Inland ECDIS in navigation mode. Inland ECDIS in information mode can also be used as a standalone system.
 - b) Navigation mode

Inland ECDIS in **navigation mode** means the use of the Inland ECDIS for conning the vessel with overlaid radar image. The fall-back mode for navigation mode is information mode.

Software used in **navigation mode** is a safety-relevant part of a navigation system. Manufacturers of navigation systems shall make sure that all software components used in **navigation mode** allow safe navigation in every situation.

Third party components shall be chosen according to the general safety requirements. The navigation system provider shall prove that third party components meet the high standards necessary for safe navigation either by providing acceptable quality certificates or by extensive and provable testing of the components.

Navigation systems may support additional services in **navigation mode** if they are useful. These services shall not interfere with other requirements in navigation mode.
4. System configurations
 - a) System configuration 1: Inland ECDIS, stand-alone-system without connection to radar

In this system configuration, it is only operational in **information mode** (see Chapter 3, Figure I-1).

- b) System configuration 2: Inland ECDIS, parallel installation and connection to radar
This system configuration allows operation in **information mode** as well as in **navigation mode** (see Chapter 3, Figure I-2).
 - c) System configuration 3: Inland ECDIS with connection to radar and shared monitor
In this system configuration, the monitor of the radar equipment is shared with the Inland ECDIS. Prerequisites for this mode are matching graphic parameters for both video signals and a video switch, which allows a fast switchover of the video sources (see Chapter 3, Figure I-3).
This system configuration allows operation in **information mode** as well as in **navigation mode**.
 - d) System configuration 4: Radar equipment with integrated Inland ECDIS functionality
This system configuration is a radar installation with integrated Inland ECDIS functionality that can be operated in **information mode** as well as in **navigation mode** (see Chapter 3, Figure I-4).
5. Inland ECDIS in **navigation mode** (operating system, application software, hardware and connected equipment) shall have a high level of reliability and availability; at least at the same level as other means of navigation (e.g. navigational radar installation).
 6. Inland ECDIS shall use chart information as specified in Part I, Chapters 4 and 6.
 7. National authorities and international bodies are recommended to consider transitional provisions when they are introducing carriage requirements for Inland ECDIS.
 8. Inland ECDIS shall meet all the requirements of the Inland ECDIS performance standard set out in this Part I.
 9. The term “boatmaster” used in this Part I shall be deemed to be equivalent to the term “shipmaster” used in the RIS Guidelines as published in the website <https://www.risdefinitions.org>.
 10. AIS is an automatic identification system for maritime vessels that complies with the technical and performance standards laid down in Chapter V of the SOLAS Convention (Safety of Life at Sea), as defined in REF#EC-200259. Inland AIS refers to the automatic identification system for inland waterway vessels as set out in Part II. In this Part I, all references to AIS refer to both maritime AIS and Inland AIS, unless specified otherwise.

11. General requirements describe general aims and conditions of the individual environments in the wheelhouse where Inland ECDIS will be used (e.g. "The latest edition of the IENC must be used"). These general requirements shall be carefully observed during the installation and operation but cannot be part of the type-approval process of the Inland ECDIS. For this reason, these requirements are not subject to Inland ECDIS operational and performance requirements, methods of test and required test results (Part V).
12. Specifications are concrete definitions of characteristics regarding the system, its hardware parts, the properties and the behaviour of the software. All of these requirements shall be tested within the type-approval process and are part of Part V (Test Part of Inland ECDIS).

Article 1.02 ***References***

References are given in Part 0, Chapter 3.

CHAPTER 2

GENERAL REQUIREMENTS AND SPECIFICATIONS OF INLAND ECDIS

Article 2.01

Contents and provision of chart information

1. Content of ENC
 - a) General requirements

All modes:

 - i) The latest edition of the IENC shall be used.
 - ii) Provisions shall be made to prevent the user from altering the content of original IENC and bathymetric IENC editions.
 - iii) If the chart producer is using overlay cells or bathymetric IENCs, the features may be included in different chart cells, but the whole package shall fulfil the minimum requirements listed in the indents below in this Article 2.01.
 - iv) The SENC shall be stored in the Inland ECDIS.
 - b) Specifications

All modes:

 - i) At least the following features shall be included in the IENC:
 - bank of waterway (at mean water level);
 - construction (e.g. groin, longitudinal control dam, training wall – any facility that is considered a hazard to navigation);
 - contours of locks and dams;
 - boundaries of the fairway/navigation channel (if defined);
 - isolated dangers in the fairway/navigation channel under water;
 - isolated dangers in the fairway/navigation channel above water level, such as bridges, overhead cables, etc.;
 - official Sign and Marking information (AtoN “aids to navigation”) including the MMSI for physical AtoNs that are equipped with AIS (e.g. buoys, beacons, lights, notice marks);
 - waterway axis with kilometres indication where it is defined;
 - location of ports and transshipment sites;
 - reference data for water level gauges relevant to navigation;
 - links to the external xml-files with operation times of restricting structures, in particular locks and bridges.

Article 2.02

Updating of chart information

1. Updates
 - a) General requirements

All modes:

 - i) Inland ECDIS shall be capable of accepting incremental updates and overlay cells to the IENC data provided in conformity with the Product Specification for IENCs and incremental updates of the depth information provided in conformity with the Product Specification for bathymetric IENCs.
 - ii) The incremental updates have to be applied consecutively to the specified edition.
 - iii) The IENC, all its incremental updates and overlay cells shall be displayed without any degradation of their information content.
 - iv) The official IENC data, their incremental updates and overlay cells shall be clearly distinguishable from other, unofficial information, e.g. provided by third parties.
 - v) The content of the SENC to be used shall be adequate and up to date for the intended voyage.
 - b) Specifications

All modes:

 - i) IENC chart updates shall be applied to the SENC automatically. The implementation procedure of the update shall not interfere with the display in use.
 - ii) Inland ECDIS shall ensure that the IENC and all its updates have been correctly loaded into the SENC.
 - iii) Inland ECDIS shall keep a record of loaded editions, updates and overlay cells, including the time of application.

Navigation mode:

 - iv) All **manual** activities concerning loading or updating of charts shall be possible only outside the navigation modes.
 - v) **Automatic** updating shall not downgrade the performance of the navigation display.

Article 2.03

Presentation of information

1. Image positioning and orientation
 - a) General requirements

Information mode:

 - i) All kinds of chart orientations are permitted.
 - b) Specifications

Navigation mode:

 - i) The chart shall be automatically positioned and oriented in the relative motion, in 'head-up' display mode. The own vessel's position on the screen may be displayed 'centred' or 'off-centred'.

- ii) Orientations other than head-up orientations are permitted in systems with an additional maritime ECDIS type approval. If such a system is used in 'true motion' and/or 'north-up' mode on European inland waterways, it is considered to be working in **information mode**.
2. Screen orientation, chart orientation, positioning and shifting
- a) General requirements
 - Information mode:**
 - i) Because of the limited space available in the typical wheelhouse of an inland vessel and the fact that a vessel usually follows the fairway-axis, it is recommended to install the monitor in portrait orientation.
 - ii) While sailing, the chart orientations "head up" as well as "positioning" are recommended, the displayed part of the chart shall automatically follow the own vessel's position.
 - b) Specifications
 - All modes:**
 - i) It shall be possible to display the own vessel's position on the screen.
 - Navigation mode:**
 - ii) Only the chart orientation 'relative motion, 'head up' and the 'centred' or 'off centred' presentations, as required for the radar picture, are permitted.
 - iii) The own vessel's position shall always be visible in the display area, whether 'centred' or 'off centred' as specified in Part II.
 - iv) The chart and the radar image shall match in size, position and orientation within the limits as specified in Chapter 2, Articles 2.03 and 2.06.
3. Position and heading of the own vessel
- a) Specifications
 - Navigation mode:**
 - i) The heading line, which runs from the display centre to the top and which shall always be visible, shall represent the heading of the own vessel.
 - ii) It shall be possible to correct an offset error (distance between the positions of the position sensor antenna and the radar antenna).
4. Display of SENC information
- a) Specifications
 - All modes:**
 - i) The display of SENC information shall be divided into the following three display categories:
 - Display Base,
 - Standard Display (Standard Information Density),
 - All Display (including other information);
 - ii) The allocation of the feature classes to the display categories is given in detail in the Look-up Tables of Annex 2.

- iii) When first (factory default) starting the Inland ECDIS, it shall come up with the Standard Information Density as defined in REF#IHO-S52 and Part 0.
- iv) Inland ECDIS shall be switchable to the Standard Information Density at any time by a single user action.
- v) Inland ECDIS shall clearly indicate, at all times, the information density in use.
- vi) Time variable depth information in the ENC shall be displayed independently of the three display categories referred to in Article 2.03(4)(a)(i).
- vii) It shall be possible for the boatmaster to select safety depth limits.
- viii) Inland ECDIS shall be capable of indicating if the water level is below the safety depth limits.

Navigation mode:

- ix) The presentation of chart information shall not mask or degrade important parts of the radar picture. This shall be ensured by appropriate entries in the look-up tables (refer also to 'radar code', Part I, Chapter 6, Article 6.02(4)).
- x) The chart and radar picture presentation shall have the same scale.
- xi) The heading line shall be always visible.
- xii) Additionally, the own vessel's contour and the safety contours may be inserted.
- xiii) The data referred to in Chapter 2, Article 2.01(1)(b)(i), 1st to 7th indent and the following elements, shall always be visible and shall not be obscured by other objects:
 - Heading line (as required in REF#CESNI-ESTRIN);
 - Bearing line (as required in REF#CESNI-ESTRIN);
 - Range rings (as required in REF#CESNI-ESTRIN);
 - Navigation lines (as required in REF#CESNI-ESTRIN);
 - P-Lines (Parallel lines for personal use);
 - Buoys;
 - Inland AIS symbols of other vessels;
 - Inland AIS labels of other vessels (if activated);
 - Sign and Marking information (AtoN including AIS AtoN).

5. Colours and symbols

a) General requirements

All modes:

- i) To present navigational elements and parameters as listed in REF#IMO-MSC232, other colours and symbols than those mentioned in Chapter 2, Article 2.03(5)(b)(ii) shall be used.
- ii) If symbols that deviate from Annex 2 are used for the presentation of any chart information, then they shall be definite and unambiguous in their meaning.

b) Specifications

All modes:

- i) The display of colours and symbols to represent SENC information shall at least comply with the regulations of Part I, Chapter 6. Additional other user-selectable symbol sets are permitted.
- ii) At least the colour combinations included in the REF#IHO-S52 Presentation Library, 6.0 (colour tables) for day, dusk and night shall be supported.
- iii) The system shall be capable of displaying all features included in a test SENC according to the Presentation Standard for Inland ECDIS (Part I, Chapter 6) correctly when the information density is switched to 'all display'. Additionally, other user-selectable symbol sets are permitted.
- iv) If symbols that deviate from Annex 2 are used for the presentation of any chart information, then they shall:
 - be legible,
 - be of sufficient size to support the nominal viewing distance.
- v) Symbols added to the Inland ECDIS Presentation Library (Annex 2) by the manufacturer shall be clearly distinguishable from Presentation Library symbols as defined in Annex 2.

6. Scale dependent information density (SCAMIN)

a) Specifications

All modes:

- i) Inland ECDIS shall implement the SCAMIN functionality (the minimum scale at which the feature may be used for ECDIS presentation).

7. Displayed features in more than one cell for the same area

a) Specifications

All modes:

- i) All features included in the SENC and in the additional overlay cell shall be visible and correctly displayed.
- ii) Bathymetric IENC shall be displayed correctly together with the base SENC in accordance with (6) of Annex 3.

8. Display of radar information

a) Specifications

Navigation mode:

- i) The radar image shall have the highest display priority and can only be presented in the relative motion, "head-up" mode.
- ii) The underlaid SENC (Inland ECDIS Chart) shall match in position, range and orientation. Both the radar image and the position from the position sensor shall be adjustable for the antenna offset to a common reference position e.g. conning position.
- iii) The overlaid radar image shall conform to the minimum requirements as specified in Chapter 2, Article 2.03(8)(a)(v) to (ix).
- iv) The overlaid radar image may contain additional navigational information. However, any additional navigational information and tracking and tracing symbols shall in no way degrade the display of the original radar content.
- v) The radar image representation is mandatory for operation. When the radar image is switched off, the system falls back to information mode.
- vi) The dimensions, resolution and attributes of the radar presentation shall fulfil the relevant radar requirements (as specified in REF#ETSI-303676).
- vii) The radar picture shall not be degraded by other contents of the displayed information.
- viii) It shall be possible to switch off the chart or any other information layer and to display only the radar picture by one easily accessible control element or menu area.
- ix) If the quality and plausibility monitoring of the Inland ECDIS detect that the chart cannot be oriented and/or positioned with the accuracy required by this Part, an alarm shall be presented on the display, and the chart shall be switched off automatically. If there is no radar signal, the information mode shall be displayed. In this case too, an alarm shall be given. The switching shall always be possible by manual action.
- x) The radar information shall be clearly distinguishable from the SENC information, independently of the chosen colour table. Only a monochrome presentation with different intensities of the current radar picture is permitted.
- xi) Trails are tracks displayed by the radar echoes of targets in the form of an afterglow. Trails may be true or relative. Relative trails are as they would be presented in relative motion. True trails are as they would be presented in true motion (as specified in REF#IEC-62388).

Trails for radar echoes should have the same colour as the radar echoes. It is also possible to show the trails in a different colour from the colour of the radar echoes, but the colour of the trails should not dominate the radar echoes. The brightness of the trails should always be lower than the radar echoes, no matter which colour or colour combination is used.

- xii) If the Inland ECDIS displays the radar picture, but the radar operation control remains at the radar equipment (see Chapter 3, Figure I-2), the radar picture of the inland ECDIS shall be considered as the “daughter display” of a radar equipment. In that case, the radar picture shall fulfil the requirements relative to the display and the pictures for radar and Rate of Turn indicators as defined in REF#CESNI-ESTRIN.
 - xiii) If the Inland ECDIS and the radar device share the same screen (see Chapter 3, Figure I-3), or if the Equipment Under Test (EUT) is a radar installation with integrated Inland ECDIS functionality (see Chapter 3, Figure I-4), all requirements of the standards for radar equipment and rate of turn indicators as defined in REF#CESNI-ESTRIN, shall be fulfilled.
9. Display of tracking and tracing information from other AIS stations
- a) General requirements
 - All modes:**
 - i) It shall be possible to display all information received by an AIS such as the blue sign, or the number of blue cones of other vessels, the status of signals and the water level on user request.
 - b) Specifications
 - All modes**
 - i) The symbols for AIS base stations, AIS Sign and Marking information (AtoN), Application Specific Messages and AIS Search and Rescue Transmitters (SART) shall be distinguished from other symbols (e.g., symbols 2.10 and 2.11, Table A.1 and Table A.2 in REF#IEC-62288).
10. Display of other navigational information
- a) General requirements
 - All modes:**
 - i) Inland ECDIS and additional navigational information (e.g. Inland AIS) shall use a common conventional geodetic coordinate reference system.
11. Data and display accuracy
- a) General requirements
 - All modes:**
 - i) The accuracy of the calculated data (e.g., measured distance or bearing) that is presented shall be independent of the display characteristics and shall be consistent with the SENC accuracy.
 - ii) The accuracy of all calculations performed by Inland ECDIS shall be independent of the characteristics of the output device and shall be consistent with the SENC accuracy.
 - iii) The accuracy of bearings and distances drawn on the display or those measured between features already drawn on the display, shall be no less than that required by the resolution of the display.

b) Specifications

Navigation mode:

- i) The Inland ECDIS shall provide an indication as to whether the display uses a smaller display range (higher zoom factor) than the accuracy that the IENC data offers (over-scale indication).
- ii) The static offset, i.e., the error between the whole radar picture and chart image, shall be less than ± 5 m in all ranges up to 2000 m.
- iii) The chart position shall match the radar image. Assuming an absolute position input, the permissible static difference between actual radar position and displayed radar centre shall not exceed 5 m.
- iv) It shall be possible for the system administrator to adjust the offset values between the physical positions of the position sensor antenna and the radar antenna of the vessel so that the SENC display matches the radar image. It is recommended to provide this function in a system administration menu.
- v) Resolution and accuracy shall at least be the same as those of the display but may not suggest better values than those of the chart data.

12. Position accuracy

a) General requirements

All modes:

- i) The positioning system and the SENC shall be based on the same geodetic datum.

Navigation mode:

- ii) The navigation system shall make reliable estimations of position. Position and heading information shall be calculated and displayed for the same reference position. This shall normally be the centre of the radar antenna.

b) Specifications

Navigation mode:

- i) The navigation system shall estimate and the Inland ECDIS shall display the position of the vessel. The following minimal requirements shall be fulfilled under normal operation conditions:
 - The estimations of position and heading shall be checked by the Inland ECDIS for conformity with the required accuracy. A new position estimate shall at least be available with every revolution of the radar antenna.
 - The average position estimation shall not deviate more than 5 metres from the true position and shall cover all systematic errors.
 - The standard deviation σ shall be less than 5 metres and based on random errors only.
 - The Inland ECDIS shall be capable of detecting positional failures.
- ii) The Inland ECDIS shall monitor the position quality indicators provided by the connected Inland AIS device and/or (D)GNSS receiver. Inland ECDIS shall indicate a warning in case of low quality position information. An alarm shall sound (optical and acoustic signal) when no position information is available.

13. Heading accuracy

a) General requirements

Navigation mode:

- i) The navigation system shall make reliable estimations of the heading. Position and heading information shall be calculated for the same reference position. This shall typically be the centre of the radar antenna.

b) Specifications

Navigation mode:

- i) The navigation system shall estimate and the Inland ECDIS shall display the heading of the vessel. The following minimal requirements shall be fulfilled:
 - A new heading estimate shall at least be available with every revolution of the radar Antenna.
 - The average heading angle estimation shall not deviate more than 1 degree from the radar heading direction and shall cover all systematic errors.
 - The offset between vessel heading direction and radar heading shall be less than 1 degree.
 - Chart and radar image shall have the same orientation. The static directional error between heading line and chart orientation shall be less than ± 0.5 degree.

14. AIS targets of other vessels

a) General requirements

All modes:

- i) Vessels' positions received by an AIS device shall be displayed. Textual information received by an AIS device shall be displayed on demand in an appropriate manner (e.g. permanent or in pick report).

Navigation mode:

- ii) Information that another vessel is carrying blue cones or lights may be displayed by a different colour of the vessel symbol.

b) Specifications

All modes:

- i) The overlay of information regarding the position and orientation of other vessels gathered by communication links, such as AIS, is only permitted when:
 - the information is up to date (real-time), and
 - the age of information does not exceed the maximum time out values provided in the Table I-1). The symbols shall be marked as outdated if the time of the information exceeds 30 seconds for moving vessels. The position information of the own vessel shall only be displayed when the position is detected by an on-board system and not if the position is received from a repeater station.

- ii) Only if the heading of other vessels is available, the position and the orientation of those other vessels may be presented by:
 - a directed triangle, aligned with vessel's longitudinal axis, or
 - a true outline (to scale). The number of the blue cones/lights shall only be displayed in the pick report.
- iii) In all other cases a generic symbol shall be used (an octagon is recommended, a circle shall not be used for applications that are certified according to maritime standards).
- iv) The following time out values are recommended according to Part II

Table I-1
Reporting interval for AIS information and time out values before removing information from the display

Category of vessel	Nominal reporting interval class A	Maximum time out value class A	Nominal reporting interval class B	Maximum time out value class B
Vessel at anchor or moored and not moving faster than 3 knots (class B not moving faster than 2 knots)	3 min	18 min	3 min	18 min
Vessel at anchor or moored and moving at more than 3 knots	10 s	60 s	3 min	18 min
Vessel operating in SOLAS mode, moving at 0 to 14 knots	10 s	60 s	30 s	180 s
Vessel operating in SOLAS mode, moving at 0 to 14 knots and changing course	3 1/3 s	60 s	30 s	180 s
Vessel operating in SOLAS mode, moving at 14 to 23 knots	6 s	36 s	30 s	180 s
Vessel operating in SOLAS mode, moving at 14 to 23 knots and changing course	2 s	36 s	30 s	180 s
Vessel operating in SOLAS mode, moving faster than 23 knots	2 s	30 s	30 s	180 s
Vessel operating in SOLAS mode, moving faster than 23 knots and changing course	2 s	30 s	30 s	180 s
Vessel operating in inland waterway mode	2 – 10 s	60 s	—	—

- v) The AIS targets of other vessels should be marked as outdated if the position information is older than half of the time out value. The information on the intention (blue sign) shall only be displayed on the right-hand side of the symbol, if the heading of the vessel is available. If no heading information is available, the information shall only be displayed in a direction independent form.
- vi) Information on the blue sign shall only be displayed if all three values can be clearly distinguished:
 - the blue sign is not connected, or the status of the connection is not available;
 - the blue sign is set;
 - the blue sign is not set.

The following table provides an example for the display:

Table I-2
Display of Blue Sign status 0 to 2 and dangerous goods

Display of Blue Sign status 0 to 2 and dangerous goods						
Blue sign	Not connected or not available		Not Set		Set	
Blue cones	No	1 to 3	No	1 to 3	No	1 to 3
Heading	No					
	Symbol					
	True shape					

- vii) Position information of the own vessel that is received from a repeater station shall not be displayed.

15. AIS AtoN

a) General requirements

All modes:

- i) Received AIS AtoN message information shall be displayed.

b) Specifications

All modes:

i) The symbols used for AIS AtoNs shall use the AIS diamond outline as depicted in the table below.

Certain symbols will provide information about the direction of impact of the AtoN.

These “combined symbols” are composed of two symbols out of the SVG symbol library:

- The “inner part” (diamond shape and included symbol),
- The “outer frame” (a enveloping circle with an peripheral arrow).

The combination of these two parts depends on the orientation of the displayed chart and has to be changed when the orientation of the chart changes:

- The “inner part” is oriented according to the top of the Inland ECDIS display.
- The “outer frame” is a transparent symbol, placed at the centre location of the “inner part” and amended with an orientation angle in accordance with Part II, Chapter 5, Table II-9. This angle points to the direction of impact of the sign.

The symbol for a certain AtoN has to be selected based on the information whether the AtoN is on position or off position, whether there is a match with an AtoN in the IENC via the MMSI and whether it is a virtual AtoN:

Table I-3
Generic symbols used for AIS AtoN depending if the AtoN is on position or not and if it matches an iENC object

	On position	Off position	
Match with IENC object		 Original position of AtoN but missing	 Current position of AtoN but off position
No match with IENC object			
Virtual AtoN		Not applicable	

- ii) If there is an AtoN object without MMSI in the IENC it is not possible to match the two objects. The AIS AtoN symbol shall be displayed in addition to the IENC object in this case.

Table I-4
Representation of an AtoN object and iENC object when they are not matching

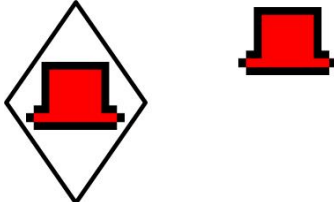
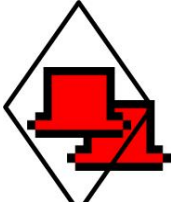
	
<p>In case both objects are not very close they are displayed next to each other.</p>	<p>In case the position of the two objects is very close the IENC object may be displayed even within the diamond shape or even behind it.</p>

- iii) The Inland AIS AtoN symbols shall use the AIS diamond outline as described in the presentation library (Annex 2). The time out for the display of Inland AIS AtoN shall be 6 times the recommended reporting interval i.e., 18 minutes.

After the time out period the Inland AIS AtoN symbol shall be immediately removed from the chart and not displayed as lost target. For the AtoNs with an IENC match the charted object will be shown instead.

The text height and the size of AIS symbols in millimetres shall not be less than 3,5 times the nominal viewing distance in metres.

The minimum size of AIS symbols and the minimum text height of AIS information shall be 3,5 mm.

16. Application Specific Messages

a) General requirements

All modes:

- i) Whenever a code from ERDMS is used, it shall be displayed as a plain text.
- ii) For the following AIS Application Specific Messages the Inland ECDIS application needs to react and/or display information (source of message between brackets):
 - Convoy message (vessel)
 - Inland Capability Interrogation Reply (vessel)
 - ETA at lock/bridge (vessel)
 - RTA at lock/bridge (shore)
 - Present Bridge Clearance (shore)
 - Water level (shore)
 - Signal station (shore)
 - Geographic notice (shore)
 - ISRS Text message (shore)
- iii) The Inland ECDIS application shall automatically enable/disable ASM functions according to the information coming from the Control Message
- iv) The Inland ECDIS application shall make it possible to provide an overview on request which ASM are currently enabled or disabled by the competent authority through the Control Message.

- v) None of the AIS ASMs shall interfere with the operational functions of the chart displayed on the screen of the Inland ECDIS.
- vi) Wherever coded data elements are provided for display to the user, only the translated plain text values shall be shown to the boatmasters. E.g., ISRS Location Codes shall be translated back into plain text using the ERDMS.
- b) Specifications
 - i) All Application Specific Message shall be displayed in all display categories unless differently stated in the description in the list below.
 - ii) The ASM will be visualised under radar unless differently stated in the description in the list below.
 - iii) Control message
No specification
 - iv) Convoy message
The received convoy information shall at least be displayed with the appropriate graphical symbol in the label or the pick report of the vessel.
If the heading for a vessel is available, a scaled symbol according to the received convoy message from this vessel may be used. In this case the heading, the position of the antenna and the length and width of the convoy shall be taken into account. The time out is 18 minutes.
 - v) Inland Capability Interrogation Reply
No specification
 - vi) ETA at lock/bridge
No specification
 - vii) RTA at lock/bridge
It shall be possible to display the list with entries of the received RTA message information on the screen of the Inland ECDIS. This can be displayed in a popup window, in the pick report of the related feature or in an icon menu.
 - viii) Present Bridge Clearance
Received vertical bridge clearance data shall be displayed as a label containing the bridge clearance, accuracy and time of the last measurement.
In addition the information shall be accessible via a separate dialogue window. Only bridges for which actual values have been received shall be shown in the overview list. The bridge names shall be automatically converted from the ISRS Location Code into the common name and shown in plain text using the ERDMS.
The vertical clearance values shall be automatically converted into meter values.
Next to the vertical clearance either the date and time of the last measurement according to the local time zone or the period since the time of the last measurement shall be shown. The date and time of the measurement shall be calculated using the time of the reception subtracted by the "time to the last measurement". The period since the time of the last measurement shall be calculated by adding the time since the reception to the received "time to the last measurement". In case the age of the vertical bridge clearance information exceeds 60 minutes the vertical bridge clearance information shall no longer be shown in the application.

The accuracy value shall be displayed in cm. In case accuracy value 0 is received “± unknown” will be displayed.

In case the accuracy value 31 is received “± > 30 cm” is displayed.

If the labels are turned off, it shall be possible to show the vertical bridge clearance, the time information and accuracy on top of the chart in a text box, by doing a mouse-over or invoking the pick report at a certain bridge opening object on the IENC.

ix) Water level

Received water level data shall be displayed in a label next to the gauge.

In addition the water level information shall be accessible via a separate dialogue window. Only water level gauge for which values have been received within the last 18 minutes shall be shown in the overview list. The water level gauge names shall be automatically converted from the gauge ID into the common name and shown in plain text using the ERDMS. The water levels shall be automatically converted from the difference value transmitted by message 24 into the real water level by adding the reference water level to the difference value.

Next to the water level the date and time of the last reception shall be shown according to the local time zone. In case the age of the water level information exceeds 18 minutes, the water level information shall no longer be shown in the application.

If the labels are turned off, it shall be possible to show the latest received water level and corresponding reception time in a text box, by doing a mouse-over or pick report at a certain water level gauge object on the IENC.

Consequently the display on board shall also only be done in cases where the message can be successfully linked to the RIS Index gauge object(s).

x) Signal station

In case a signal status message is received the matching signal symbol (Annex 15, Figure 15-1) shall be displayed instead of the matching (through the ISRS Location Code) IENC object. Therefore, it can only be displayed with an IENC match. Otherwise, the message will be discarded.

The displayed orientation shall follow the value given in the Inland AIS message.

The time out shall be 4 minutes.

The signal icon shall only be displayed with the same SCAMIN value as the matching IENC object.

In case the symbol is no longer displayed because of the SCAMIN value, there shall be a visual indication that a dynamic signal station information is available for the object. At mouse over the full signal symbol shall be displayed.

xi) Geographic notice

The geographic notice shall be displayed as an area with at least an outline whether or not filled with a transparent background. The defined areas can be circles, rectangles, polygons or sectors. They can also be defined as a simple point or a series of points connected as a polyline.

The Geographic Notice message can be made up of multiple subareas in which case the total area is the unionsum of the subareas. This message can also be used to convey advisory lines or tracks (using the polyline subarea); however, the Route Information message should be used for recommended or directed routes (Article 3.05(5)(g)(i)).

The Geographic Notice shall be displayed between the starting date/time and the duration period. If a cancellation message is received, the Geographic Notice will be removed from the display.

If a Geographic Notice (except for a cancellation message) is received without a valid start date/time and duration then it should be discarded.

The time out for this message shall be 3 times the reporting rate with a maximum of 30 minutes.

A Geographic Notice shall always be visible in all display categories unless differently mentioned in the Table I-5. The same messages shall always be under radar unless differently mentioned in theTable I-5.

Table I-5
Geographic notice types

Value	Description	Minimal display category Display base = 0 Standard display = 1 All display = 2	On radar No = 0 Yes = 1
0	Caution: Marine mammal habitat	1	0
1	Caution: Marine mammals–in area - reduce speed	1	0
2	Caution: Marine mammals–in area - stay clear	1	0
3	Caution: Marine mammals–in area - report sightings	1	0
4	Caution: Protected–Habitat - reduce speed	1	0
5	Caution: Protected–habitat - stay clear	1	0
6	Caution: Protected–habitat - no fishing or anchoring	1	0
7	Caution: Derelicts (drifting objects)	1	0
8	Caution: Traffic congestion	1	0
9	Caution: Marine event or regatta	1	0
10	Caution: Divers down	1	1
11	Caution: Swim area	1	0
12	Caution: Dredge operations	1	0

Value	Description	Minimal display category	On radar
13	Caution: Survey operations	1	0
14	Caution: Underwater operation	1	1
15	Caution: Seaplane operations	1	0
16	Caution:–Fishery - nets in water	1	1
17	Caution: Cluster of fishing vessels	1	0
18	Caution: Fairway closed	1	1
19	Caution: Harbour closed	1	1
20	Caution: Submerged pipeline or cable	1	0
21	Caution: Unmanned vehicle operation	1	0
22	Caution: other (define in associated text field)	1	0
23	Environmental Caution: Storm front (line squall)	1	0
24	Environmental Caution: Hazardous sea ice i.e. icebergs and growlers	1	0
25	Environmental Caution: Storm warning (storm cell or line of storms)	1	0
26	Environmental Caution: High wind	1	0
27	Environmental Caution: High waves	1	0
28	Environmental Caution: Restricted visibility (fog, rain, etc)	1	0
29	Environmental Caution: Strong currents	1	0
30	Environmental Caution: Heavy icing	1	0
31	Environmental Caution: Oil or other hazardous substance in area	1	0
32	Environmental Caution: other (define in associated text field)	1	0
33	Restriction: Fishing prohibited	1	0
34	Restriction: Entry approval required prior to transit	1	0
35	Restriction: Entry prohibited	1	1
36	Restriction: Active military OPAREA	1	0
37	Restriction– Firing - danger area	1	0
38	Restriction: Drifting mines	1	1
39	Restriction: other (define in associated text field)	1	0
40	Anchorage: Anchorage open	1	0
41	Anchorage: Anchorage closed	1	0
42	Anchorage: Anchoring prohibited	1	0

Value	Description	Minimal display category	On radar
43	Anchorage: Deep draft anchorage	1	0
44	Anchorage: Shallow draft anchorage	1	0
45	Anchorage: Vessel transfer operations	1	0
46	Anchorage: other (define in associated text field)	1	0
47	Ice Report: Ice Edge	1	0
48	Ice Report: New Ice (< 10 cm ocean < 5 cm lake)	1	0
49	Ice Report: Young Ice (10-30 cm)	1	0
50	Ice Report: Thin 1st year ice (30-70 cm ocean, 5-15 cm lake)	1	0
51	Ice Report: Medium 1st year ice (70-120 cm ocean, 15-30 cm lake)	1	0
52	Ice Report: Thick 1st year ice (120-200 cm ocean, 30-70 cm lake)	1	0
53	Ice Report: Old /very thick ice (> 200 cm ocean, > 70 cm lake)	1	0
54	Ice Report: Undetermined or unknown thickness	1	0
55	Reserved for Future Use	n.a.	n.a.
56	Security Alert - Implement USA MARSEC Level 1	n.a.	n.a.
57	Security Alert - Implement USA MARSEC Level 2	n.a.	n.a.
58	Security Alert - Implement USA MARSEC Level 3	n.a.	n.a.
59	Reserved for Future Use	n.a.	n.a.
60	Reserved for Future Use	n.a.	n.a.
61	Reserved for Future Use	n.a.	n.a.
62	Reserved for Future Use	n.a.	n.a.
63	Reserved for Future Use	n.a.	n.a.
64	Distress: Vessel disabled and adrift	0	1
65	Distress: Vessel sinking	0	1
66	Distress: Vessel abandoning ship	0	1
67	Distress: Vessel requests medical assistance	0	1
68	Distress: Vessel flooding	0	1
69	Distress: Vessel fire/explosion	0	1
70	Distress: Vessel grounding	0	1
71	Distress: Vessel collision	0	1
72	Distress: Vessel listing/capsizing	0	1

Value	Description	Minimal display category	On radar
73	Distress: Vessel under assault	0	1
74	Distress: Person overboard	0	1
75	Distress: SAR area	0	1
76	Distress: Pollution response area	0	1
77	Distress: other (define in associated text field)	0	1
78	Reserved for Future Use	n.a	n.a
79	Reserved for Future Use	n.a	n.a
80	Instruction: Contact VTS at this point/juncture	1	1
81	Instruction: Contact Port Administration at this point/juncture	1	1
82	Instruction: Do not proceed beyond this point/juncture	1	1
83	Instruction: Await instructions prior to proceeding beyond this point/juncture	1	1
84	Instruction: Proceed to this location – await instructions	1	0
85	Instruction: Clearance granted – proceed to berth/lock	1	0
86	Instruction: other (define in associated text field)	1	0
87	Reserved for Future Use	n.a	n.a
88	Information: Pilot boarding position	2	0
89	Information: Icebreaker waiting area	2	0
90	Information: Places of refuge	2	0
91	Information: Position of icebreakers	2	0
92	Information: Location of response units	2	0
93	Information: VTS active target	2	0
94	Information: Rogue or suspicious vessel	2	0
95	Information: Vessel requesting non-distress assistance	1	0
96	Information: other (define in associated text field)	2	0
97	Chart Feature: Submerged object / sunken vessel (describe in associated text field)	2	0
98	Chart Feature: Semi-submerged object	2	0
99	Chart Feature: Shoal area	2	0
100	Chart Feature: Shoal area due north	2	0
101	Chart Feature: Shoal area due east	2	0

Value	Description	Minimal display category	On radar
102	Chart Feature: Shoal area due south	2	0
103	Chart Feature: Shoal area due west	2	0
104	Chart Feature: Channel obstruction	2	0
105	Chart Feature: Reduced vertical clearance	0	1
106	Chart Feature: Bridge/Gate/Lock/other closed	1	1
107	Chart Feature: Bridge/Gate/Lock/other partially open (opening)	1	1
108	Chart Feature: Bridge/Gate/Lock/other fully open	1	1
109	Chart Feature: Bridge/Gate/Lock/other partially closed (closing)	1	1
110	Chart Feature: Bridge/Gate/Lock/AtoN/other inoperative or not working properly	1	1
111	Chart Feature: other (define in associated text field)	1	1
112	Report from vessel: Icing info	2	0
113	Report from vessel: Intended route	1	0
114	Report from vessel: other (define in associated text field)	1	0
115	Reserved for Future Use	n.a	n.a
116	Reserved for Future Use	n.a	n.a
117	Reserved for Future Use	n.a	n.a
118	Reserved for Future Use	n.a	n.a
119	Reserved for Future Use	n.a	n.a
120	Route: Recommended Route	1	1
121	Route: Alternative Route	1	1
122	Route: Recommended Route through ice	1	1
123	Route: other (define in associated text field)	1	1
124	Reserved for Future Use	n.a	n.a
125	Other – Define in associated text field	2	0
126	Cancellation – cancel area as identified by Message Linkage ID	n.a	n.a
127	Undefined (default)	n.a	n.a

xii) ISRS Text message

Received data shall be displayed as a label containing the text message.

In addition the information shall be accessible via a separate dialogue window. The time out for this message should be 18 minutes. If a time out occurs the Text message disappears from the display.

If the text parameter of the ISRS Text message starts with two @ characters, the associated text shall be removed from the display.

Article 2.04 **Operation**

1. Operation

a) General requirements

Information mode:

- i) All kinds of chart orientation, rotation, zooming and panning are allowed. However, it is recommended to use the same fixed ranges as in the **navigation mode** and the chart orientation either:
 - to the north,
 - to the fairway axis at the actual position, or
 - to the actual vessel's heading.
- ii) Inland ECDIS may be connected to a positioning sensor to move the chart picture automatically and to display the section of the chart matching the actual surrounding, namely in the user-selected range.

Navigation mode:

- iii) Information that another vessel is carrying blue cones or lights may be displayed by a different colour of the vessel symbol.

b) Specifications

Navigation mode:

- i) Manual switching between **navigation mode** and **information mode** shall be possible.
- ii) The operation mode in use shall be displayed.
- iii) It shall be possible to temporarily remove either the ECDIS or the radar information by a single user action.
- iv) Information regarding the position and orientation of other vessels, gathered by communication links other than their own radar, may be displayed only if they are up to date (nearly real-time) and meet the accuracy that is required for the support of tactical and operational navigation.

2. Ergonomics of control elements

a) General requirements

Navigation mode:

- i) The symbols of the control elements shall be readable under all conditions that may exist in a wheelhouse.
- ii) Wireless remote controls are not permitted.

- b) Specifications
 - All modes:**
 - i) The operation of the system shall be simple, appropriate and conform to common human interface standards. The operational state of the system and the connected peripherals shall be clearly indicated.
 - ii) The symbols of the control elements shall have a minimum character height of 4 mm.
 - Navigation mode:**
 - iii) The brightness and the illumination of the control elements shall be adjustable to the required value.
 - iv) The number of control elements shall be as low as possible and restricted to the required number.
 - v) The ON/OFF switch shall perform and be arranged in such a way that an inadvertent action is not possible.
- 3. Characteristics of control elements
 - a) Specifications
 - All modes:**
 - i) All control elements shall be checked regarding the ergonomic and functional mode of operation and shall fulfil the appropriate requirements of this Part I.
 - ii) Additional national language versions may be introduced by the manufacturer under the manufacturer's own responsibility.
- 4. Pick report
 - a) Specifications
 - All modes:**
 - i) It shall be possible to obtain all underlying textual and/or graphical information concerning user selections of the features that are displayed in the chart.
 - ii) This additional textual and/or graphical information shall not hamper the view of the waterway in the navigational chart.
- 5. Measuring features
 - a) Specifications
 - All modes:**
 - i) Measuring features for distances and bearings are required.
- 6. Input and editing of boatmasters' own chart entries
 - a) Specifications
 - All modes:**
 - i) Inland ECDIS shall allow input, storing, modification and deletion of additional chart information by the boatmaster (own features).
 - Navigation mode:**
 - ii) These own chart entries shall be distinguishable from the SENC data. The boatmaster shall be able to add only his/her own single point-shaped objects in navigation mode without switching to information mode.

7. Scales, Ranges/Range rings

a) General requirements

Information mode:

- i) All scales and ranges are permitted.

b) Specifications

Navigation mode:

- i) The following fixed ranges and range rings are prescribed according to the radar regulations:

Range	Range rings
500 m	100 m
800 m	200 m
1 200 m	200 m
1 600 m	400 m
2 000 m	400 m
4 000 m	1 000 m

- ii) Smaller and larger ranges with a minimum of four and a maximum of six range rings are permitted.
- iii) Only the successive switchable ranges (scales) are permitted.
- iv) Inland ECDIS shall have fixed range rings with the intervals set out in Chapter 2, Article 2.04(7)(b)(i) and (ii) and at least one VRM.
- v) Switching on/off of fixed and variable range ring markers shall be independent of each other and their display shall be clearly distinguishable.
- vi) The position of the VRM and the corresponding displayed distance shall use the same increments and resolution.
- vii) The functions of the VRM and the EBL may also be realised by a cursor and by a corresponding numerical display, showing range and bearing of the cursor position.
- viii) All numeric displayed values of the EBL and the VRM shall match exactly with the analogue positions of the EBL and the VRM (or correspond to the cursor coordinates).
- ix) The resolution and increments of the numerical display shall be identical to the analogue values of EBL and VRM.

8. Inland ECDIS pre-sets (store/recall)

a) General requirements

Navigation mode:

- i) Other parameters than brightness may come up with values from stored settings.

b) Specifications

Navigation mode:

- i) After starting, the Inland ECDIS shall come up with a moderate brightness pre-set which neither blinds in a dark environment nor makes the picture indecipherable in a bright environment.

9. Control elements
- a) General requirements
- All modes:**
- i) Control elements, and indicators for connected sensors, may be integrated into Inland ECDIS.
- b) Specifications
- All modes:**
- i) Inland ECDIS shall be designed in accordance with ergonomic principles for user-friendly operation.
- ii) The Inland ECDIS shall have a minimum of control elements (see Part V).
- iii) Standard settings and user-defined settings shall be easy to find and recover.
- iv) The following operational functions require direct access:
- "range",
 - "brightness",
 - "colours",
 - "information density".
- v) These functions shall have either their own control elements or own menu areas, which are arranged in the highest menu level and are permanently visible.
- vi) The following function parameters shall always be visible:
- range (actual range);
 - status (sensor status: alarms, and - if connected - GNSS receiver, AIS and heading device);
 - water level (selected water level, if available);
 - safety depth (selected safety depth, if available);
 - information density (selected information density).
- Navigation mode:**
- vii) The following function parameters shall always be visible:
- sensor status (radar tuning, position quality).
10. AIS targets of other vessels
- a) Specifications
- All modes:**
- i) It shall be possible to switch off Inland AIS labels, either manually or on the base of a configured time out value.
11. AIS AtoN
- a) General requirements
- No general requirements
- b) Specifications
- No specifications

12. Application Specific Messages

- a) General requirements
 - No general requirements
- b) Specifications

When the Inland ECDIS is connected to an AIS device which is able to support the ASMs the following specifications are applicable.

All modes:

- i) Control message
 - The Inland ECDIS shall use the content of the Control message to enable or disable the creation of ASMs.
- ii) Convoy message
 - It shall be possible to configure the convoy information outside the chart on the Inland ECDIS by using e.g., a separate dialogue window. Therefore, a list with graphical examples of the convoy types shall be available. This list is in compliance with Annex 10 of the ES-RIS.
 - The entry of the convoy information should be done before starting the voyage or whenever the configuration of the convoy is changing.
 - The convoy information consists of the formation code, the ENI and the load condition per craft. It shall be possible to choose the loading status in plain text from the possible choices.
 - The Inland ECDIS shall check that the formation code and the number of craft data (ENI and loading status) transmitted in the message match.
 - The convoy message shall be controlled in accordance with the information send by the control report (Annex 15, Table 15-6) and the time out value received in the control message shall be ignored. The convoy message can't be transmitted by default unless the received control message enables it.
 - The reporting rate should be 6 minutes and can't be set by the control message.
- iii) Inland Capability Interrogation Reply
 - When the Inland AIS is receiving an Inland Capability Interrogation message, the Inland ECDIS application shall create an Inland Capability Reply message as input for the AIS to broadcast in accordance with Part VI, Article 9.02(4).
- iv) ETA at lock/bridge
 - The boatmaster shall have the possibility to send out his Estimated Time of Arrival (ETA) at a certain location. The entry of the information shall be done in a separate window of Inland ECDIS outside the chart and shall not disturb normal operational functions. The Application Specific Message ETA message shall be constructed by the Inland ECDIS application according to the requirements described in Annex 15, Table 15-4.
 - If the Inland ECDIS receives a negative acknowledgment by the AIS the process is stopped and the relevant information shall be displayed.

- If the RTA message is not received within 15 minutes, the ETA shall be transmitted a second time automatically by the Inland ECDIS.
- If the RTA message is not received within 15 minutes after the second attempt, the relevant information shall be displayed.
- v) RTA at lock/bridge
 - It shall be possible for the boatmaster to delete entries from the list of received RTA messages.
- vi) Present Bridge Clearance
 - No specifications
- vii) Water level
 - No specifications
- viii) Signal station
 - No specifications
- ix) Geographic notice
 - The Message Linkage ID and the source MMSI of Application Specific Messages shall be used to link additional text (e.g., a separate Linked Text message). This information must be included in both the Geographic Notice and additional Linked Text message.
 - The total area defined by one Geographic Notice (one Message Linkage ID) is the union of all of the sub-areas contained in the message.
 - If the same Message Linkage ID is retransmitted with different sub-areas and/or times, the presentation software should replace the old area with the new.
 - The Message Linkage ID must be unique across all ASMs to which it applies. In this way, the Message Linkage ID and Source MMSI are connected to the same text message.
- x) ISRS Text message
 - No specifications

Article 2.05 **Service functions**

1. Service functions
 - a) Specifications
 - All modes:**
 - i) Service functions shall be protected by password or other suitable measures against unauthorised access.
 - Information mode:**
 - ii) The following service functions shall not be selectable in **navigation mode** although these functions have an impact on navigation mode:
 - static correction of the chart position,
 - static correction of the chart orientation,
 - configuration of interfaces.
- These functions should only be performed in information mode.

Article 2.06

Hardware requirements

1. Hardware
 - a) General requirements

Navigation mode:

 - i) Inland ECDIS in navigation mode shall be designed and manufactured to withstand typical environmental conditions prevailing on board of a vessel without any degradation in quality and reliability. Furthermore, it shall not disturb other communication and navigation equipment.
 - b) Specifications

Navigation mode:

 - i) In the system configuration 4, as described in Part I, Chapter 3, Figure I-4, all components of Inland ECDIS installed inside the wheelhouse shall fulfil the requirements of equipment categorized as 'b) protected from weather' as specified in the REF#EN-60945, with the exception that the test temperature range is limited to 0 °C to + 40 °C (whereas the test temperature range in REF#EN-60945 is specified from – 15 °C to + 55 °C). For the system configuration 2 and system configuration 3, described in Part I, Chapter 3, Figure I-2 and Figure I-3, CE conformity is sufficient.
 - ii) The last sentence of i) does not apply to monitors operated in navigation mode in system configuration 3 (Part I, Chapter 3, Figure I-3) nor to hardware components used for providing radar information from the radar processor for display on the Inland ECDIS screen.
 - iii) Inland ECDIS in system configuration 4, as described in Part I, Chapter 3, Figure I-4, and visual display units operated in navigation mode in system configuration 3, and hardware components used for providing radar information from the radar processor for displaying this on the Inland ECDIS screen, shall fulfil the requirements of REF#EN-60945 concerning the resistance to environmental conditions (humidity, vibration and temperature; the temperature reduced according to Chapter 2, Article 2.06(1)) and concerning electromagnetic compatibility.
 - iv) The provider or his/her representative shall submit a relevant conformity declaration of an accredited laboratory.
2. Display
 - a) General Requirements

All modes:

 - i) The display method shall ensure that the displayed information is clearly visible to more than one observer in the typical conditions of light exposed in the wheelhouse of a vessel by day and night.
 - b) Specifications

All modes:

 - i) The following requirements shall be fulfilled:
 - Alphanumeric data and text shall be presented using a clearly legible non-italic sans-serif font.

- The font size shall be appropriate for the viewing distance from user positions (i.e. with respect to reading distance and viewing angles) likely to be experienced in the wheelhouse of a vessel.
 - The character height and the size of AIS symbols in millimetres shall not be less than 3.5 times the nominal viewing distance in metres.
 - The minimum size of AIS symbols and the minimum character height of AIS information shall be 3,5 mm.
- ii) The display shall fulfil the requirements in landscape and in portrait format.

Navigation mode:

- iii) The integrated display shall be in accordance with the requirements for radar on inland waterways as specified in Chapter 2, Article 2.03(8).

3. Screen dimensions

a) General requirements

Information mode:

- i) It is recommended to use the size of the screen as specified for navigation mode (see Chapter 2, Article 2.06(3)(b)(iii)). In the event that space for the installation of the monitor is a problem, the screen size might be reduced taking into account the nominal viewing distance for the screen.
- ii) Ergonomic aspects shall determine the size. The information displayed must be readily visible from the conning position.

b) Specifications

Information mode:

- i) The screen diagonal shall be equal to or larger than 199 mm (7.85 inches). A length of at least 15 inches is recommended. Under all conditions the boatmaster must be capable of perceiving the displayed information sufficiently in accordance with Human Machine Interface guidelines.

Navigation mode:

- ii) The minimum chart display area on the screen shall be at least 270 mm by 270 mm. The effective diameter of the visible radar picture on the screen shall not be less than 270 mm.

4. Screen resolution

a) Specifications

Information mode:

- i) A display resolution of 5 m in the 1 200 m range is recommended. This leads to a maximum pixel dimension of 2,5 m × 2,5 m, i.e. about 1 000 pixels at the short edge of the screen.

Navigation mode:

- ii) A display resolution of 5 m in the 1 200 m range is required. This leads to a maximum pixel dimension of 2,5 m × 2,5 m, i.e. about 1 000 pixels at the short edge of the screen.

5. Display colours
 - a) Specifications

All modes:

 - i) The system shall be able to display the chart in ergonomically proven colour combinations for day, dusk and night.

6. Display and screen brightness
 - a) Specifications

All modes:

 - i) The brightness of the display shall be adjustable to every operational required value. This is especially valid for the lowest value during operation at night.

Navigation mode:

 - ii) The brightness of the features and radar echoes shall not exceed a value of 5 cd/m², and the background a value of 0,1 cd/m².
 - iii) Chart and radar pictures shall have separate brightness controls.
 - iv) Because of substantial differences of environmental brightness between a bright day and a dark night, another control for the basic brightness of the display shall be available in addition to the colour tables in the menu.

7. Picture refresh rate
 - a) Specifications

Navigation mode:

 - i) The picture refresh rate shall not be shorter than that of the radar picture (≥ 24 pictures per minute).
 - ii) Between two consecutive refreshes no fluctuations of brightness shall occur.
 - iii) On raster scan monitors, the frame repetition rate shall not be lower than 60 Hz and the switching time shall not exceed 50 ms.

Article 2.07
Connection of other equipment

1. Connection of other equipment
 - a) General requirements

All modes:

 - i) It is permitted for Inland ECDIS to generate information to other systems, e.g. for the purpose of electronic reporting.
 - ii) The relevant requirements of controls and indicators to connected equipment shall be fulfilled.
 - b) Specifications

All modes:

 - i) Inland ECDIS shall consider that there might be more than one position source of different quality.

Navigation mode:

- ii) Inland ECDIS shall not affect the performance of any connected sensors adversely. Similarly, the connection of optional sensors shall not degrade the performance of Inland ECDIS.
- iii) Electronic circuits shall be designed to be failsafe, mechanically as well as electronically, and shall not have degrading repercussions on connected sensors.

2. Configuration of interfaces

a) Specifications

All modes:

- i) It shall be possible to configure interfaces for connected sensors, actors and signals.
- ii) Interfaces shall comply with existing interface specifications as defined in REF#IEC-61162, and the interface specifications for rate of turn indicators (20 mV/deg/min) as defined in REF#CESNI-ESTRIN.

3. Accuracy of rate of turn indicators

a) Specifications

Navigation mode:

- i) When the ROT is less than ± 60 deg/min, the dynamic deviation between the chart orientation and the radar picture shall be less than ± 3 degrees.
- ii) The deviation between the displayed ROT and the ROT provided by the connected ROT indicator shall be less than ± 3 deg/min.

Article 2.08
Warning and alarm indicators

1. Built-in Test Equipment (BITE)

a) Specifications

Navigation mode:

- i) Inland ECDIS in navigation mode shall be provided and have the means to carry out on-board tests of major functions, either automatically or manually. In case of a failure, the module at fault shall be shown.

2. Malfunctions

a) Specifications

Information mode:

- i) Inland ECDIS shall provide an appropriate alarm or warning indicator of missing input from – if connected – GNSS receiver, AIS and heading device.

Navigation mode:

- ii) Inland ECDIS shall provide an appropriate alarm or warning indicator of system malfunctions (refers to iv below).

- iii) Inland ECDIS shall provide appropriate alarms of malfunction of the essential connected peripherals and sensors (e.g. Inland AIS, radar, heading device etc.) with respect to the displayed information (e.g. map matching, wrong chart orientation, wrong own position).
- iv) Inland ECDIS shall provide appropriate warnings of malfunction of non-essential connected peripheral or sensor (e.g. wind sensor) with respect to the displayed information.
- v) As a requirement, at least the following situations shall be covered:
 - any error in the Inland ECDIS (built-in test equipment — BITE),
 - missing positioning signal,
 - missing radar signal,
 - missing rate of turn signal,
 - missing heading signal,
 - radar image and map impossible to superimpose properly,
 - missing AIS signal.
- vi) The navigation system shall check proper operation of the position and heading estimation in real-time. Problems shall be detected within 30 seconds. In case of malfunction, the navigation system shall inform the user about the problem and its consequences for navigation.
- vii) If a critical sensor alarm signals that the position or the heading does not meet the required accuracy criteria, the navigation chart shall be switched off.
- viii) Inland ECDIS shall provide an alarm if the input from the position-fixing system is lost.
- ix) Inland ECDIS shall also repeat, but only as a warning, any alarm or other warning passed to it from a position fixing system.

Article 2.09 **Fall-back arrangements**

- 1. Insufficient accuracy of the SENC-positioning
 - a) Specifications
 - Navigation mode:**
 - i) The SENC shall be automatically switched off if the SENC positioning does not match the radar picture within the limits set out in Part I, Chapter 2, Article 2.03(11)(b)(iii) and Article 2.03(13)(a)(i).
- 2. Defects
 - a) General requirements
 - Navigation mode:**
 - i) Facilities enabling a safe take-over of the functions of Inland ECDIS shall be provided in order to ensure that an Inland ECDIS failure does not result in a critical situation.

b) Specifications

Navigation mode:

- i) If the Inland ECDIS has a defect, it shall provide a suitable alarm (refers to Part I, Chapter 2, Article 2.08(2)(a)(iv)).

Article 2.10
Quality requirements

1. Endurance Test

a) General requirements

Navigation mode:

- i) The Inland ECDIS shall run for at least 48 hours of uninterrupted operation under normal operation conditions. The system shall provide standard interfaces for performance and resource monitoring during operation. Monitoring the system shall show no indication of system instability, memory leaking or any kind of performance loss over time. Inland ECDIS supporting additional services shall provide the necessary test equipment including all documents mentioned under Chapter 2, Article 2.10(2)(b)(i).

2. Documentation

a) General requirements

All modes:

- i) A user's manual shall be delivered with every Inland ECDIS installed on a vessel.
- ii) The technical documentation shall be complete, appropriate, and understandable, and that it is sufficient for unproblematic installation, configuration and operation of the Inland ECDIS.
- iii) In addition, the operating manual shall describe the measures required by the user in an adequate and appropriate way.

b) Specifications

All modes:

- i) The documentation (manuals) shall contain comprehensive information on the installation, operation and service of the Inland ECDIS. The presentation of user-relevant information shall be clear, understandable and without unnecessary technical terms. The user manual should be available, preferably in all supported languages of the user interface, but shall be available at least in English. The technical system description may be made available in English only.
- ii) The manufacturer's documentation shall identify the nominal viewing distance for the screen.

Information mode:

- iii) If the software is sold as a standalone product, without hardware, the manufacturer's documentation shall include the information that it may only be used as Inland ECDIS if the hardware fulfils the display requirements of this Part.

Navigation mode:

- iv) The following documents shall be provided for admittance and shall be delivered with every Inland ECDIS used in navigation mode:
 - user's manual,
 - installation manual,
 - service manual.
- v) The following documents and files shall be provided during the admittance procedure and are not required for end users:
 - design specifications.
- vi) The documents and files provided shall allow for a complete verification of compliance with the Inland ECDIS technical specifications.

3. Interfaces

a) Specifications

All modes:

- i) All interfaces shall be documented correctly and completely.

Information mode:

- ii) The Inland ECDIS manufacturers must confirm in their system documentation that the system includes those test procedures and signal indicators, according to Chapter 2, Article 2.08.

Article 2.11***Changes to certified navigation systems***

1. Manufacturer's declaration

a) General requirements

Navigation mode:

- i) Inland ECDIS installed on board shall be functionally equivalent to a system certified by the authorities. For every system, the Inland ECDIS provider shall send a statement of compliance with the Inland ECDIS technical specifications and its functional equivalence to the certified system.

2. Hardware and software changes

a) General requirements

Navigation mode:

- i) The Inland ECDIS provider may change software or hardware as long as compliance with this standard is maintained. Changes shall be fully documented and submitted to the competent authority, together with an explanation of how the navigation system is affected by those changes. The competent authority may require a partial or complete renewal of certification if considered necessary. This also applies to the use of an approved Inland ECDIS with another national version of the operating system.

- ii) The following changes do not affect certification of the system and require only a notice to the competent authority:
- minor changes on third party components (e.g. operation system or library updates),
 - use of equivalent or better hardware components (e.g. faster microprocessor, newer chip revisions, equivalent graphic card, etc.),
 - minor changes in source code or documentation.

CHAPTER 3
SYSTEM CONFIGURATIONS (FIGURES)

Figure I-1
Inland ECDIS, self-sufficient system without connection to radar
(system configuration 1)

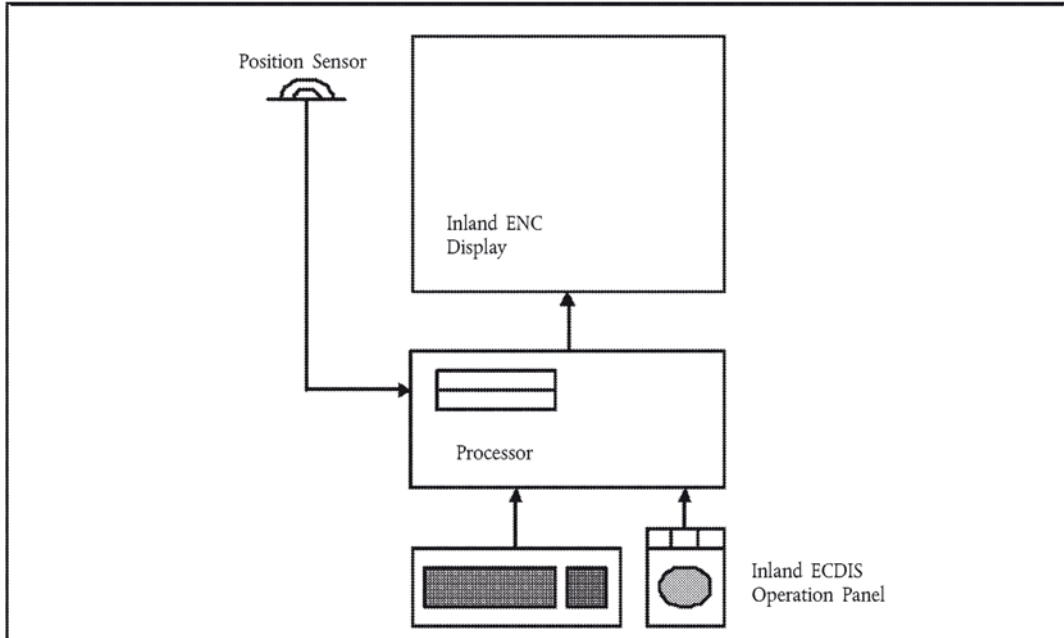

Figure I-2
Inland ECDIS, parallel installation with connection to radar
(system configuration 2)

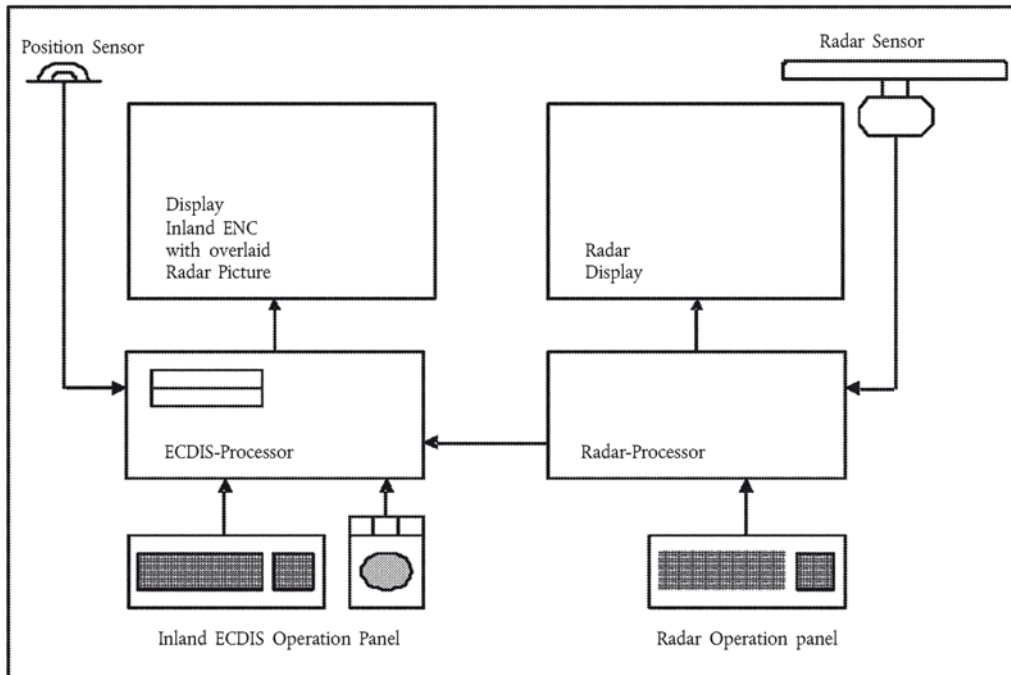

Figure I-3
Inland ECDIS with connection to radar and shared monitor
(system configuration 3)

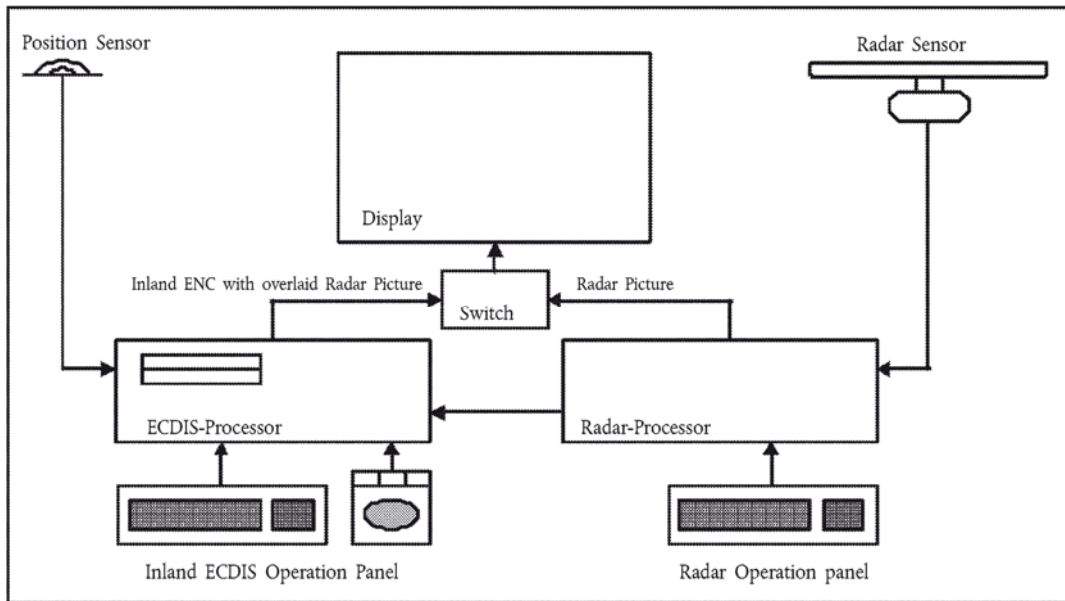
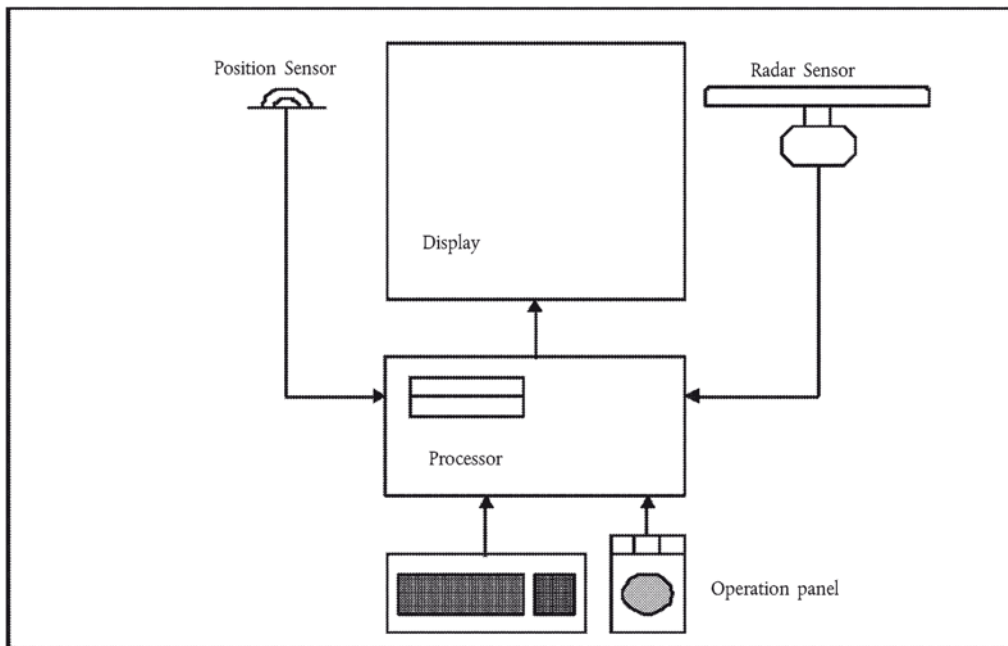

Figure I-4
Navigational radar equipment with integrated Inland ECDIS functionality
(system configuration 4)



CHAPTER 4

DATA STANDARD FOR IENCs

Article 4.01

Introduction

1. The Data Standard for IENCs describes the technical specifications to be used
 - a) for the exchange of digital hydrographic data between national inland waterway authorities, and
 - b) for its distribution to manufacturers, boatmasters and other users.
2. This Data Standard shall be used for the production of IENCs and bathymetric IENCs. The transfer and distribution of IENCs and bathymetric IENCs shall be done in such a way that data integrity is ensured.
3. This Data Standard is based on REF#IHO-S57.
4. This Data Standard describes the necessary additions and clarifications to REF#IHO-S57 and the application of REF#IHO-S57 for the purpose of use in Inland ECDIS.
5. This Data Standard shall be compliant to standards and regulations indicated in Annex 1 and Annex 3.

Article 4.02

Theoretical data model

The description of the theoretical data model in Part 2 of REF#IHO-S57 shall apply to the theoretical data model of IENCs and bathymetric IENCs.

Article 4.03

Data structure

The description of the data structure in Part 3 of REF#IHO-S57 shall apply to the data structure of IENCs and bathymetric IENCs.

Article 4.04

Product specifications for IENCs and bathymetric IENCs

1. The Product Specifications for IENCs and for bathymetric IENCs enable chart producers to produce a consistent IENC or bathymetric IENC, and manufacturers to use that data efficiently in an Inland ECDIS that satisfies the Performance Standard for Inland ECDIS set out in Chapter 1.

2. Data for ENC's shall be made available to all manufacturers of applications. An IENC shall be produced in accordance with the rules laid down in Annex 1 and shall be encoded using the following documents referred to therein:
 - a) the IENC Feature Catalogue, and
 - b) the rules described in the IENC Encoding Guide.
3. A bathymetric IENC shall be produced in accordance with the rules laid down in Annex 3 and shall be encoded using:
 - a) the bathymetric IENC Feature Catalogue (Annex 3) and
 - b) the rules described in the IENC Encoding Guide (Annex 1).
4. IENCs and bathymetric IENCs approved for navigation mode shall be produced in accordance with the 'Data Standard' and the 'Product Specification' referred to in this Chapter.

Article 4.05
Validation Checks

1. An ENC shall be approved in accordance with the test procedure defined in annex 5.
2. The outcome of the tests envisaged by the test procedure must be that no critical error is found.
3. The competent authority shall ensure that the test procedure has been implemented in accordance with (1) and (2) before publishing an IENC.

CHAPTER 5
CODES FOR PRODUCERS AND WATERWAYS
(IN ADDITION TO REF#IHO-S62 ENC PRODUCER CODES)

1. Codes for producers of IENCs, as well as the registration procedure, are those mentioned in REF#IHO-S62.
2. Administrations or private companies which produce IENCs and are not mentioned in REF#IHO-S62 and administrations or private companies that decide to produce IENCs, shall register a producer code at the REF#IHO-S100 registry at <http://registry.iho.int>
3. When competent authorities are designated by Member States for the provision of river information services through dedicated systems and for the international exchange of data, the following applies:
 - a) Since a producer code alone is not sufficient to establish whether an IENC is appropriate to be used in navigation mode, the competent authorities shall maintain and provide via their official website an up-to-date list of IENCs approved for navigation mode within their geographical area of responsibility.
 - b) The list mentioned in (a) shall include the file name of the IENC cell, the stretch of the inland waterway that is covered, the edition number, the issue date and a list of available update files to the currently valid edition also with their issue dates.
 - c) The list mentioned in (a) shall include all IENCs for which the cell complies with the requirements regarding the minimum content and is approved for navigation mode.
4. When a Member State has the obligation to notify the competent authorities to a regulatory body, then the following applies:
 - a) The notification shall include information on the geographical area of responsibility and the official website of the competent authorities.
 - b) The Member State shall notify immediately of any changes relative to the elements mentioned in (a).
5. The waterway codes in the file name of IENC should be defined by the competent waterway authorities.

CHAPTER 6

PRESENTATION STANDARD FOR INLAND ECDIS

Article 6.01

Introduction

1. This Presentation Standard for Inland ECDIS describes the technical specifications to be used for the presentation of Inland ECDIS data. The presentation shall be produced in such a way that no information is lost.
2. This Presentation Standard is based on REF#IHO-S52.
3. This Presentation Standard describes the necessary additions and clarifications to REF#S52 and the application of REF#S52 for the purpose of use in Inland ECDIS.
4. The presentation of Inland ECDIS data shall meet the requirements of the Presentation Standard described in Chapter 6 and Annex 2.
5. Definitions of terms may be found in:
 - a) Part 0,
 - b) Part 1, clause 5 of REF#IHO-S57,
 - c) REF#IHO-S32.

Article 6.02

The presentation library for Inland ECDIS

1. REF#IHO-S57 data sets describe the data standard for IENCs, but they do not contain any information about how the data will be presented. The chart presentation is generated online in the Inland ECDIS. For that purpose, the Inland ECDIS uses machine-readable symbolization instructions for each feature that is represented on the screen. For the presentation of ENCs, the REF#IHO-S52 is mandatory. The REF#IHO-S52 contains all the rules necessary for the symbolization and presentation of ENCs on the screen.
2. Since the features, attributes and attribute values for ENCs were extended for IENCs and bathymetric IENCs, an extension of the REF#IHO-S52 is necessary in order to be able to display also the Inland specific features. All extensions apply to REF#IHO-S52.
3. Components of REF#IHO-S52 and Inland ECDIS presentation library
 - a) The major components of the REF#IHO-S52 presentation library are:
 - i) A library of symbols, line styles and fill styles;
 - ii) A colour coding scheme which includes the IHO colour tables for day, dusk and night-time;

- iii) A set of symbology command words from which machine-readable instructions can be assembled. The result is a symbology instruction, which is processed to symbolize ENC features in turn;
 - iv) A set of conditional symbology procedures to decide on the appropriate symbolization in cases determined by the boatmaster's selection (e.g. safety contour) or for complex symbols (e. g. top marks on buoys and beacons);
 - v) A set of look-up tables that link feature descriptions from the ENC to the appropriate symbology instructions depending on whether:
 - the link is straight forward, i.e. a direct relationship between a feature's description and its presentation such as a buoy or a land area. In this case, the look-up table provides the symbology instruction to show a symbol, an area fill or a line style,
 - the link is conditional, i.e. depending on circumstances, for example a depth area, where the colour fill depends on the choice of the safety contour. In this case the look-up table refers the decision to a conditional symbology procedure that later selects the appropriate symbology instructions.
- b) Inland ECDIS shall use all REF#IHO-S52 components, plus extensions, in:
- i) look-up tables,
 - ii) symbol library,
 - iii) conditional symbology procedures.
- The extensions are described in Annex 2.

4. Look-up tables

- a) The major components of the REF#IHO-S52 presentation library are:
- i) 6-character code of the feature class (acronym);
 - ii) Attribute combination;
 - iii) Symbolization instructions;
 - iv) Display priority, 0-9 (comparable with drawing layers);
 - v) Radar code;
 - vi) Display category (display base, standard, all others);
 - vii) 'Viewing group', more refined grouping of features than the display categories.

Figure I-5
Example entry of a look-up table

"LNDMRK","CATLMK17 ","SY(TOWERS01)","7","O","OTHER","32250"

In this case the feature LNDMRK is shown by the symbol TOWERS01 with priority 7, if the attribute CATLMK equals 17. The feature lies over the radar.

The presentation of features in a specific area that are contained in different cells of the same usage follows the entries in the look-up tables.

- b) The presentation library provides five look-up tables:
 - i) paper chart point symbols,
 - ii) simplified point symbols,
 - iii) line symbols,
 - iv) plain area boundary symbols,
 - v) symbolized area boundary symbols.
- 5. Conditional symbology procedures (CS)
 - a) CS procedures shall be generated for features of which the symbolisation
 - i) depends on application settings, e.g. safety contour,
 - ii) depends on other features, e.g. top marks and their structure,
 - iii) is too complex to be defined in a direct look-up table entry.
 - b) CS procedures, which shall be modified or implemented in an Inland ECDIS, additional to the CS procedures of REF#IHO-S52, are described in Annex 2.
- 6. Colours
 - a) Colours used in an ECDIS are defined in an absolute manner, independently from the monitor used (using CIE coordinates). This ensures that ECDIS charts look similar on monitors from different suppliers. CIE values are converted into RGB values by means of colour calibration software which must be used by the manufacturer.
 - b) Commercial displays usual in the trade are seen as matching those requirements.
 - c) Due to the fact that various light conditions might occur on the bridge of a vessel, it is necessary to offer presentations with different brightness levels. For each level, a separate colour table exists.
 - d) The represented colour scheme shall be chosen on the basis of ergonomic and physiological factors and the representation of indications in different colours shall not result in mixed colours by superimposing them.
- 7. Presentation of notice marks
 - a) Notice marks which are located at the river-bank are presented in the chart displayed by generic symbols (notmrk01, notmrk02 and notmrk03). This does not apply to the notice marks on bridges.
 - b) Additionally, applications are required so the detailed symbol can be displayed, which is similar to the real-world indication, and the full set of object information of a user-selected notice mark.
 - c) Notice marks that are located on bridges shall be symbolized according to the orientation of the bridge.
 - d) Notice marks which specify distances, or a velocity, shall not be symbolized with the number itself, but only with the symbol that gives the general regulation or information.

PART II

VESSEL TRACKING AND TRACING FOR INLAND NAVIGATION

CHAPTER 1

GENERAL PROVISIONS

Article 1.01

Introduction

The technical specifications for Vessel Tracking and Tracing (VTT) systems is based on the work carried out in this field by relevant international organizations, namely already existing standards and technical specifications in inland navigation, maritime or other relevant areas.

Due to the application of VTT systems in mixed traffic areas including both inland and maritime navigation environments, like sea ports and coastal areas VTT systems shall be compatible with the AIS Class A mobile stations as referred to in Chapter V of the SOLAS convention.

Article 1.02

References

References are given in Part 0, Chapter 3.

Article 1.03

Definitions

Definitions are given in Part 0, Chapter 2.

Article 1.04

Vessel Tracking and Tracing services and minimum requirements of Vessel Tracking and Tracing systems

1. VTT systems shall be able to support the following services:
 - a) Navigation,
 - b) Traffic Information,
 - c) Traffic Management,
 - d) Calamity Abatement,
 - e) Transport Management,
 - f) Enforcement,
 - g) Waterway dues and port infrastructure charges,
 - h) Fairway Information Services,
 - i) Statistics.

2. VTT systems might be able to support also the following services:
 - a) Information for transport logistics,
 - b) Information for law enforcement (cross-border management for immigration service and customs, compliance with requirements for traffic safety, compliance with environmental requirements),
 - c) Waterway charges and harbour dues.

3. The most important information of VTT relates to vessel identity and its position. VTT shall be capable of providing - at minimum - the following information on an automatic and periodical basis to other vessels and shore stations, provided these vessels or shore stations are appropriately equipped:
 - a) Unique vessel ID: unique European vessel identification number (ENI)/International Maritime Organisation number (IMO number);
 - b) Vessel name;
 - c) Vessel call sign;
 - d) Navigational status;
 - e) Type of vessel or convoy;
 - f) Dimensions of vessel or convoy;
 - g) Draught;
 - h) Dangerous cargo indication (number of blue cones in compliance with ADN);
 - i) Loading status (loaded/unloaded);
 - j) Destination;
 - k) Estimated Time of Arrival (ETA) at destination;
 - l) Number of persons on board;
 - m) Position (+ quality indication);
 - n) Speed (+ quality indication);
 - o) Course Over Ground (COG) (+ quality indication);
 - p) Heading (HDG) (+ quality indication);
 - q) Rate of turn (ROT);
 - r) Blue sign information;
 - s) Timestamp of position fix.

These minimum requirements indicate the user needs and the necessary data for VTT systems in inland navigation.

A VTT system is designed to offer sufficient flexibility to accommodate future additional requirements.

CHAPTER 2

INLAND VESSEL TRACKING AND TRACING FUNCTIONS

Article 2.01 **Introduction**

1. This Chapter sets out the requirements relating to VTT information for different RIS service categories. Requirements for each service category are listed describing the user groups and usage of the VTT information.
2. The overview of VTT information needs is provided in Part II, Article 2.08, Table II-1.

Article 2.02 **Navigation**

1. Vessel tracking and tracing can be used to support the active navigation on board. Main user group are the helmsmen.
2. The process navigation can be divided in three phases:
 - a) navigation, medium-term ahead,
 - b) navigation, short-term ahead,
 - c) navigation, very short-term ahead.
3. The user requirements are different for each phase.
 - a) Navigation, medium-term ahead
Navigation, medium-term ahead, is the navigation phase in which the boatmaster observes and analyses the traffic situation looking some minutes up to an hour ahead and considers the possibilities of where to meet, pass or overtake other vessels.
The traffic image needed is the typical 'looking around the corner' feature and is mainly outside the scope of the on-board radar range.
The update rate is depending on the task and differs from the situation in which the vessel is involved.
 - b) Navigation, short-term ahead
Navigation, short-term ahead, is the decision phase in the navigation process. In this phase traffic information has relevance for the process of navigation, including collision avoidance measures if necessary. This function deals with the observation of other vessels in the close surroundings of the own vessel.
The actual traffic information shall be exchanged continuously at least every 10 seconds. For some routes the authorities may set a predefined update rate (maximum two seconds).

c) Navigation, very short-term ahead

Navigation, very short-term ahead, is the operational navigation process. It consists of execution of the decisions that were made beforehand, on the spot and monitoring their effects. The traffic information needed from other vessels especially in this situation is related to its own vessel conditions, such as relative position, relative speed. It is necessary to follow highly accurate information in this phase.

Therefore, Tracking and Tracing information cannot be used for very short-term navigation.

Article 2.03
Vessel traffic management

Vessel traffic management (VTM) comprises at least of the following elements:

1. Vessel traffic services

Vessel traffic services consist of the following services:

- an information service,
- a navigational assistance service,
- a traffic organisation service.

The user groups of Vessel Traffic Services (VTS) are VTS operators and helmsmen.

The user needs related to traffic information are indicated in (a) to (c).

a) Information service

An information service is provided by broadcasting information at fixed times and intervals or when deemed necessary by the VTS or at the request of a vessel, and may include reports on the position, identity and intentions of other vessels, waterway conditions, weather conditions, hazardous situations or any other factors that may influence the vessel's transit.

For the information services an overview of traffic in a network or on fairway stretch is required.

The competent authority may set a predefined update rate if needed for safe and reliable passage through the area.

b) Navigational assistance service

A navigational assistance service informs the helmsman on difficult navigational or meteorological circumstances or assists the helmsman in case of defects or deficiencies. This service is normally rendered at the request of a vessel or by the VTS when deemed necessary.

To provide individual information to a helmsman, the VTS operator needs an actual detailed traffic image.

The actual traffic information has to be exchanged continuously (every three seconds, almost real time or another predefined update rate set by the competent authority).

All other information has to be made available on request of the VTS operator or in special occasions.

c) Traffic organisation service

A traffic organisation service concerns the operational management of traffic and the planning of vessel movements to prevent congestion and dangerous situations, and is particularly relevant in times of high traffic density or when the movement of special transports may affect the flow of other traffic. The service may also include establishing and operating a system of traffic clearances or VTS sailing plans or both in relation to priority of movements, allocation of space (such as berthing places, lock space, sailing routes), mandatory reporting of movements in the VTS area, routes to be followed, speed limits to be observed or other appropriate measures which are considered necessary by the VTS Authority.

2. Lock planning and operation

The lock planning processes - long- and medium-term - and lock operation process are described in (a) to (c). Main user groups are lock operators, helmsmen, shipmasters and fleet managers.

a) Lock planning, long-term

Long-term lock planning is dealing with the planning of a lock some hours up to a day ahead.

In this case the traffic information is used to improve the information on waiting and passing times at locks, which are originally based on statistical information.

Estimated Time of Arrival (ETA) shall be available on demand or shall be exchanged if the deviation from the original ETA exceeds the deviation allowed by the competent authority. Requested time of arrival (RTA) is the response to an ETA report or may be sent from a lock to propose a locking time.

b) Lock planning, medium-term

Medium-term lock planning is dealing with the planning of a lock up to two or four lock cycles ahead.

In this case the traffic information is used to map the arriving vessels to the available lock cycles and based on the planning to inform the helmsmen about the RTA.

ETA shall be available on request or shall be exchanged if the deviation from the original ETA exceeds the deviation allowed by the competent authority. All other information shall be available once at the first contact or on request. RTA is the response to an ETA report or may be sent from a lock to propose a locking time.

c) Lock operation

In lock operation phase the actual locking process take place.

The actual traffic information has to be exchanged continuously or another predefined update rate set by the competent authority.

The accuracy of VTT information does not allow for high-precision applications like closing of lock gates.

3. Bridge planning and operation

The bridge planning processes — medium- and short-term — and bridge operation process are described in (a) to (c). Main user groups are bridge operators, helmsmen, shipmasters and fleet managers.

a) Bridge planning, medium-term

The bridge planning process on medium term is dealing with the optimisation of the traffic flow in such a way that the bridges are opened in time for passing of vessels (green wave). The planning horizon varies between 15 minutes to two hours. The timeframe depends on the local situation.

ETA and position information shall be available on request, or such information shall be exchanged as soon as the deviation between the updated ETA and the original ETA exceeds a pre-defined value set by the competent authority. All other information shall be available once at the first contact or on request. RTA is the response on an ETA report or may be sent from a bridge to propose a passage time.

b) Bridge planning, short-term

In case of bridge planning on a short term, decisions are made on the basis of the strategy for opening of the bridge.

Actual traffic information on the position, speed and direction, shall be available on request or exchanged in accordance with predefined update rate, for example, every five minutes, set by the competent authority. ETA and position information shall be available on request, or such information shall be exchanged as soon as the deviation between the updated ETA and the original ETA exceeds a pre-defined value set by the competent authority. All other information shall be available once at the first contact or on request. RTA is the response on an ETA report or may be sent from a bridge to propose a passage time.

c) Bridge operation

In bridge operation phase the actual opening and passing of the vessel through the bridge take place.

The actual traffic information shall be exchanged continuously or at another update rate set by the competent authority.

The accuracy of VTT information does not allow for high-precision applications like opening or closing of the bridge.

Article 2.04 Calamity abatement

1. Calamity abatement in this context focuses on repressive measures: dealing with real accidents and providing assistance during emergencies. Main user groups are operators in calamity centre, VTS operators, helmsmen, shipmasters and the competent authorities.
2. In the case of an accident the traffic information can be provided automatically or the responsible organisation shall ask for the respective information.

Article 2.05

Transport management

Transport management (TS) is divided into the following four activities:

1. voyage planning,
2. transport logistics,
3. port and terminal management,
4. cargo and fleet management.

Main user groups are shipmasters, freight brokers, fleet managers, consignors, consignees, supply forwarders, port authorities, terminal operators, lock operators and bridge operators.

1. Voyage planning

Voyage planning in this context focuses on the planning on-trip. During the voyage the shipmaster shall check his original planned voyage.

2. Transport logistics

Transport logistics consist of the organisation, planning, execution and control of the transport.

All traffic information is needed on request by the ship-owner or logistic stakeholders.

3. Intermodal port and terminal management

Intermodal port and terminal management considers the planning of resources in ports and at terminals.

The terminal and port manager shall request for traffic information or shall agree that in predefined situations the traffic information will be sent automatically.

4. Cargo and fleet management

Cargo and fleet management considers the planning and optimising the use of vessels, arranging cargo and transportation.

The shipper or ship-owner shall request the traffic information or traffic information shall be sent in predefined situations.

Article 2.06

Enforcement

1. The scope of the enforcement task is limited to the services on dangerous goods, immigration control and customs. Main user groups are customs, competent authorities and shipmasters.
2. The traffic information shall be exchanged with appropriate authorities. The traffic information exchange shall take place on request or at fixed predefined points or in special circumstances defined by the responsible authority.

Article 2.07
Waterway dues and port infrastructure charges

1. In various locations in the Union, usage of the waterway and ports is subject to the payment of fees. Main user groups are competent authorities, shipmasters, fleet managers, waterway authorities and port authorities.
2. The traffic information shall be exchanged on request or at fixed points, defined by the competent waterway or port authority.

Article 2.08
Information needs

Table II-1 provides an overview of the information needs of the different services.

Table II-1
Overview of information needs

	Identification	Name	Call sign	Navigational status	Type	Dimensions	Draught	Dangerous cargo	Loading status	Destination	ETA at destination	Number of persons	Position and time	Speed	Course/direction	Heading	Rate of turn	Blue sign	Other information	
Navigation – medium-term	X	X		X	X	X		X	X	X			X	X	X				X	
Navigation - short-term	X	X		X	X	X		X	X	X			X	X	X	X			X	
Navigation - very short-term	Requirements are currently not met by VTT																			
VTM — VTS services	X	X		X	X	X	X	X	X	X		X	X	X	X				X	
VTM — lock operation	X	X		X	X		X	X					X		X					Air draught
VTM — lock planning	X	X		X	X	X	X	X					X	X	X					number of assisting tugboats, air draught, ETA/RTA
VTM — bridge operation	X	X			X	X							X	X	X					Air draught
VTM — bridge planning	X	X		X	X	X							X	X	X					Air draught, ETA/RTA

	Identification	Name	Call sign	Navigational status	Type	Dimensions	Draught	Dangerous cargo	Loading status	Destination	ETA at destination	Number of persons	Position and time	Speed	Course/direction	Heading	Rate of turn	Blue sign	Other information	
Calamity abatement	X	X			X			X	X	X		X	X		X					
TM — voyage planning	X	X				X	X		X	X			X	X						Air draught, ETA/RTA
TM — transport logistics	X	X									X		X		X					
TM — port and terminal management	X	X		X	X	X		X	X				X		X					ETA/RTA
TM — cargo and fleet management	X	X		X			X		X	X			X		X					ETA/RTA
Enforcement	X	X		X	X			X		X	X	X	X		X					
Waterway and port infrastructure charges	X	X			X	X	X			X			X							

CHAPTER 3

INLAND AIS TECHNICAL SPECIFICATION

Article 3.01

Introduction

1. In maritime navigation, the IMO has introduced the carriage of automatic identification system (AIS): all seagoing vessels on international voyage falling under Chapter V of the SOLAS convention have to be equipped with AIS Class A mobile stations since the end of 2004.
2. REF#EC-200259 establishes a Community vessel traffic monitoring and information system for seagoing vessels carrying dangerous or polluting goods using AIS for Ship Reporting and Monitoring.
3. AIS is considered as a suitable solution for automatic identification and Vessel Tracking and Tracing in inland navigation. Especially the real time performance of AIS and the availability of worldwide standards and guidelines are beneficial for safety related applications.
4. To serve the specific requirements of inland navigation, AIS has to be further developed to the so-called Inland AIS technical specification while preserving full compatibility with maritime AIS and already existing standards and technical specifications in inland navigation.
5. Because Inland AIS is compatible with the maritime AIS it enables a direct data exchange between seagoing and inland vessels navigating in mixed traffic areas.
6. AIS is:
 - a) a system introduced by the IMO to support maritime safety of navigation; mandatory carriage requirement for all vessels in accordance with Chapter V of SOLAS convention;
 - b) operating in direct ship-to-ship mode as well as in a ship-to-shore, shore-to-ship mode;
 - c) a safety system with high requirements regarding availability, continuity and reliability;
 - d) a real time system thanks to the direct ship-to-ship data exchange;
 - e) an autonomously operating system in a self-organised manner without master station. There is no need for a central controlling intelligence;
 - f) based on international standards and procedures in accordance with Chapter V of SOLAS convention;
 - g) a type approved system to enhance safety of navigation following a certification procedure;
 - h) globally interoperable.

7. The purpose of this Chapter is to define all necessary technical requirements, amendments and extensions to the existing AIS Class A mobile stations in order to create an Inland AIS mobile station for use in inland navigation.

Article 3.02 **Scope**

1. The AIS is a ship-borne radio data system, exchanging static, dynamic and voyage related vessel data between equipped vessels and between equipped vessels and shore stations. Ship-borne AIS stations broadcast the vessel's identity, position and other data in regular intervals. By receiving these transmissions, ship-borne or shore-based AIS stations within the radio range can automatically locate, identify and track AIS equipped vessels on an appropriate display like radar or electronic chart display systems such as the Inland Electronic Chart Display and Information System (Inland ECDIS) as defined in Part I. AIS is intended to enhance safety of navigation in ship-to-ship use, surveillance (VTS), Vessel Tracking and Tracing, and calamity abatement support.
2. AIS mobile stations are divided into following types:
 - a) Class A mobile stations to be used by all sea going vessels falling under carriage requirements of Chapter V of SOLAS convention;
 - b) Inland AIS mobile station, having full Class A functionality on VHF Data Link level, deviating in supplementary functions designed for the use by inland vessels;
 - c) Class B SO/CS mobile stations with limited functionality which may be used by vessels not falling under carriage requirements for Class A or Inland AIS mobile stations;
 - d) AIS shore stations, including AIS base stations and AIS repeater stations.
3. The following modes of operation can be distinguished:
 - a) ship-to-ship operation: all AIS equipped vessels are able to receive static and dynamic information from all other AIS equipped vessels within the radio range;
 - b) ship-to-shore operation: data from AIS equipped vessels can also be received by AIS shore stations connected to the RIS centre where a traffic image (Tactical Traffic Image and/or Strategic Traffic Image) can be generated;
 - c) shore-to-ship operation: voyage and safety related data from shore to vessel can be transmitted.
4. A characteristic of AIS is the autonomous mode, using self-organised time division multiple access (SOTDMA), without any need for an organising master station. The radio protocol is designed in a way that vessel stations operate autonomously in a self-organised manner by exchanging link access parameters. Time is divided into one minute frames with 2250 time slots per radio channel which are synchronised by GNSS UTC time. Each participant organises its access to the radio channel by choosing free time slots considering the future use of time slots by other stations. There is no need for a central intelligence controlling the slot assignment.

5. An Inland AIS mobile station consists in general of the following components:
 - a) VHF transceiver (one transmitter, two receivers),
 - b) GNSS receiver,
 - c) data processor.
6. Universal ship-borne AIS, as defined by IMO, ITU and IEC, and recommended for the use in inland navigation uses SOTDMA in the VHF maritime mobile band. AIS operates on the internationally designated VHF frequencies AIS 1 (161,975 MHz) and AIS 2 (162,025 MHz) and can be switched to other frequencies in the VHF maritime mobile band.
7. To serve the specific requirements of inland navigation, AIS has to be further developed to the so called Inland AIS while preserving compatibility with the maritime AIS.
8. Vessel Tracking and Tracing systems in inland navigation shall be compatible with AIS Class A mobile stations, as defined by IMO. Therefore, Inland AIS messages shall be able to provide the following types of information:
 - a) static information, such as official vessel number, call sign of vessel, name of vessel, type of vessel;
 - b) dynamic information, such as vessels position with accuracy indication and integrity status;
 - c) voyage related information, such as length and beam of convoy, dangerous cargo on board;
 - d) inland navigation specific information, such as number of blue cones/lights according to ADN or ETA at lock/bridge/terminal/border.
9. For moving vessels the update rate for dynamic information on tactical level shall be between 2 and 10 seconds. For vessels at anchor it is recommended to have an update rate of several minutes, or an update triggered when information is amended.
10. Inland AIS mobile station does not replace, but supports navigational services such as radar target tracking and VTS. Inland AIS mobile station provides an additional input for navigational information: its value added is to provide means of surveillance and tracking of vessels equipped with Inland AIS. The position accuracy derived from Inland AIS mobile station using the internal (uncorrected) GNSS is typically above 10 metres. When the position is corrected using DGNSS from either maritime beacon differential correction service, AIS Message 17 or EGNOS (SBAS) the accuracy is typically below 5 metres. Due to their different characteristics, Inland AIS mobile station and radar complement each other.

Article 3.03 ***Requirements***

1. General requirements
 - a) Inland AIS mobile station is based on the AIS Class A mobile station in accordance with SOLAS convention.
 - b) Inland AIS mobile station shall cover the main functionality of AIS Class A mobile stations while considering the specific requirements for inland navigation.

- c) Inland AIS shall be compatible to the maritime AIS and shall enable a direct data exchange between seagoing and inland vessels navigating in a mixed traffic area.
- d) The requirements set out in Part II, Chapter 3, Articles 3.03 to 3.05 are complementary or additional requirements for Inland AIS, which differs from the AIS Class A mobile stations.
- e) The Inland AIS mobile station design shall take into account the ‘Technical clarifications on the Vessel Tracking and Tracing standard’.
- f) The default setting of the transmission power shall be high power and shall only be set to low power if directed so by the competent authority.

2. Information content

Only Tracking and Tracing and safety related information shall be transmitted via Inland AIS mobile station.

The information content set out in a) to e) below shall be implemented in a way that it can be sent from an Inland AIS mobile station without the need for an external application.

The Inland AIS messages shall contain following information (items marked with ‘*’ have to be handled differently as for seagoing vessels):

a) Static vessel information

The static vessel information for inland vessels shall have the same parameters and the same structure as in the AIS Class A mobile stations as far as it is applicable. Any conversions from inland to maritime parameters shall be done automatically where feasible. Unused parameter fields shall be set to ‘not available’.

Inland specific static vessel information shall be added.

Static vessel information is broadcast autonomously from vessel or on request.

User identifier (MMSI)	in all messages
Name of vessel	AIS Message 5
Call sign of the vessel	AIS Message 5
IMO number	AIS Message 5 (not available for Inland vessels)
Type of vessel/convoy and cargo*	AIS Message 5 + Inland FI 10
Overall length (decimetre accuracy)*	AIS Message 5 + Inland FI 10
Overall beam (decimetre accuracy)*	AIS Message 5 + Inland FI 10
Unique European vessel identification number (ENI)	Inland FI 10
Reference point of reported position on the vessel (location of antenna)*	AIS Message 5

b) Dynamic vessel information

The dynamic vessel information for inland vessels shall have the same parameters and the same structure as in AIS Class A mobile stations as far as it is applicable. Not used parameter fields shall be set to ‘not available’.

Inland specific dynamic vessel information shall be added.

Dynamic vessel information is broadcasted autonomously from vessel or on request.

Position according to World Geodetic System from 1984 (WGS 84)	AIS Message 1, 2 and 3
Speed Over Ground (SOG)	AIS Message 1, 2 and 3
Course COG	AIS Message 1, 2 and 3
Heading HDG	AIS Message 1, 2 and 3
Rate of turn ROT	AIS Message 1, 2 and 3
Position accuracy (GNSS/DGNSS)	AIS Message 1, 2 and 3
Time of electronic position fixing device	AIS Message 1, 2 and 3
Navigational status	AIS Message 1, 2 and 3
Status of Blue sign*	AIS Message 1, 2 and 3
Quality of speed information	Inland FI 10
Quality of course information	Inland FI 10
Quality of heading information	Inland FI 10

c) Voyage related vessel information

The voyage related vessel information for inland vessels shall have the same parameters and the same structure than in AIS Class A mobile stations as far as it is applicable. Unused parameter fields shall be set to 'not available'.

Inland specific voyage related vessel information shall be added.

Voyage related vessel information is broadcasted autonomously from vessel or on request.

Destination (ISRS Location Code)	AIS Message 5
Category of dangerous cargo	AIS Message 5
ETA	AIS Message 5
Maximum present static draught*	AIS Message 5 + Inland FI 10
Dangerous cargo indication	Inland FI 10
Loaded/unloaded vessel	Inland FI 10

d) Number of persons on board

The number of persons on board is transmitted either as a broadcast message or as an addressed message from vessel to shore on request or on event.

Number of crew members on board	Inland FI 55
Number of passengers on board	Inland FI 55
Number of shipboard personnel on board	Inland FI 55

e) Safety related messages

Safety related messages (i.e. text messages) are transmitted when required as broadcast or as addressed messages.

Addressed Safety related message	AIS Message 12
Broadcasted Safety related message	AIS Message 14

3. Reporting interval of information transmission

- a) The different information types of Inland AIS messages shall be transmitted with different reporting rates.
- b) The reporting rate for dynamic information can be switched between autonomous mode and assigned mode for moving vessels in inland waterway areas. The reporting rate can be increased up to 2 seconds in assigned mode. The reporting behaviour shall be switchable from an AIS base station (via AIS Message 23 for group assignment or Message 16 for individual assignment) and by commands from external ship-borne systems, via REF#IEC-61162 interface as defined in Annex 9.
- c) For static and voyage related the reporting rate shall be 6 minutes, on request, or if information is amended.
- d) Following reporting rates shall be applicable:

Static vessel information	Every 6 minutes, on request or when data has been changed
Dynamic vessel information	Depends on navigational status and vessel operating mode, either autonomous (default) or assigned mode, see Table II-2
Voyage related vessel information	Every 6 minutes, on request or when data has been changed
Number of persons on board	As required or on request
Safety related messages	As required
Application Specific Messages	As required (to be defined by competent authority)

Table II-2
Update rate of dynamic vessel information

Vessel dynamic conditions	Nominal reporting interval
Vessel status 'at anchor' and not moving faster than 3 knots	3 minutes ¹⁾
Vessel status 'at anchor' and moving faster than 3 knots	10 seconds ¹⁾
Vessel operating in autonomous mode, moving 0 to 14 knots	10 seconds ¹⁾
Vessel operating in autonomous mode, moving 0 to 14 knots and changing course	3 1/3 seconds ¹⁾
Vessel operating in autonomous mode, moving 14 to 23 knots	6 seconds ¹⁾
Vessel operating in autonomous mode, moving 14 to 23 knots and changing course	2 seconds
Vessel operating in autonomous mode, moving faster than 23 knots	2 seconds
Vessel operating in autonomous mode, moving faster than 23 knots and changing course	2 seconds
Vessel operating in assigned mode ²⁾	assigned between 2 seconds and 10 seconds
¹⁾ When a mobile station determines that it is the semaphore (refer to REF#ITU-R1371a), the reporting rate shall increase to once per two seconds (refer to REF#ITU-R1371b).	
²⁾ Shall be switched by competent authority, when necessary.	

4. Technology platform
 - a) The platform for Inland AIS mobile station is the AIS Class A mobile station.
 - b) The technical solution of Inland AIS mobile station is based on the same technical standards as AIS Class A mobile stations (REF#ITU-R1371 and REF#IEC-61993).
5. Compatibility to AIS Class A mobile stations

Inland AIS mobile stations shall be compliant to AIS Class A mobile stations and shall be capable of receiving and processing all AIS messages (according to REF#ITU-R1371 and REF#IALA-1371) and in addition the messages defined in Part II, Article 3.04.

6. Unique identifier

In order to guarantee the compatibility with maritime vessels, the MMSI number shall be used as a unique station identifier (radio equipment identifier) for the Inland AIS mobile stations.

7. Application requirements

- a) Information referred to paragraph 2 shall be input, stored and displayed directly within the Inland AIS mobile station.
- b) The Inland AIS mobile station shall be capable of storing also the inland specific static data in the internal memory, in order to keep the information when the unit is without power supply.
- c) Necessary data conversions for the Minimum Keyboard Display (MKD) of the Inland AIS information content (e.g. knots into km/h) or MKD input and display of information concerning inland vessel types shall be handled within the Inland AIS mobile station.
- d) Application Specific Messages (ASM) should be entered/displayed by an external application with the exemption of Inland AIS ASM DAC = 200 FI = 10 (Inland Ship static and voyage related data) and DAC = 200 FI = 55 (inland number of persons on board) which are implemented directly in the Inland AIS mobile station.
- e) In order to program the inland specific data into the AIS transponder the digital interface sentences are defined in Annex 9.
- f) The Inland AIS mobile station shall provide — as a minimum — an external interface for the input of DGNSS correction and integrity information according to the provisions of the RTCM Special Committee 104 on DGNSS.

8. Type-approval

Inland AIS mobile station shall be type-approved for compliance with these technical specifications.

Article 3.04 **Protocol amendments for Inland AIS mobile station**

Due to evolution of REF#ITU-R1371, several parameters allow for the use of new status codes. This does not harm the functioning of the AIS but may result in display of unrecognized status codes in equipment based on previous revisions of the standard.

1. Position report

Table II-3
Position report

Parameter	Bits	Description
Message ID	6	Identifier for this message 1, 2 or 3
Repeat indicator	2	Used by the repeater to indicate how many times a message has been repeated 0-3; Default = 0; 3 = do not repeat any more
User ID (MMSI)	30	MMSI-number
Navigational Status	4	0 = under way using engine; 1 = at anchor; 2 = not under command; 3 = restricted manoeuvrability; 4 = constrained by her draught; 5 = moored; 6 = aground; 7 = engaged in fishing; 8 = under way sailing; 9 = reserved for future amendment of Navigational Status for a highspeed craft; 10 = reserved for future amendment of Navigational Status for Wing In Ground (WIG); 11 = power-driven vessel towing astern (regional use) ¹⁾ ; 12 = power-driven vessel pushing ahead or towing alongside (regional use) ¹⁾ ; 13 = reserved for future use; 14 = AIS-SART (active); 15 = not defined = default (also used by AIS)
Rate of turn ROT AIS	8	0 to + 126 = turning right at up to 708 deg/min or higher 0 to - 126 = turning left at up to 708 deg/min or higher Values between 0 and 708 deg/min coded by ROT AIS = 4.733 SQRT (ROTsensor) deg/min where ROTsensor is the rate of turn as input by an external rate of turn Indicator. ROT AIS is rounded to the nearest integer value + 127 = turning right at more than 5° per 30 s (No Turn Indicator available) - 127 = turning left at more than 5° per 30 s (No Turn Indicator available) - 128 (80 hexadecimal) indicates no turn information available (default). ROT data should not be derived from COG information
Speed over ground	10	Speed over ground in 1/10 knot steps (0-102,2 knots) 1 023 = not available; 1 022 = 102,2 knots or higher ²⁾
Position accuracy	1	The position accuracy (PA) flag should be determined in accordance with REF#ITU-R1371 1 = high (≤10 m) 0 = low (> 10 m) 0 = default

Parameter	Bits	Description
Longitude	28	Longitude in 1/10 000 min ($\pm 180^{\circ}$, East = positive (as per 2's complement), West = negative (as per 2's complement), 181= (6791AC0 hexadecimal) = not available = default)
Latitude	27	Latitude in 1/10 000 min ($\pm 90^{\circ}$, North = positive (as per 2's complement), South = negative (as per 2's complement), 91= (3412140 hexadecimal) = not available = default)
Course over ground	12	Course over ground in $1/10^{\circ}$ (0-3599). 3 600 (E10 hexadecimal) = not available = default; 3 601 — 4 095 shall not be used
True heading	9	Degrees (0-359) (511 indicates not available = default).
Time stamp	6	UTC second when the report was generated by the electronic positioning fixing system (EPFS) (0-59, or 60 if time stamp is not available, which shall also be the default value, or 61 if positioning system is in manual input mode, or 62 if Electronic Position Fixing System operates in estimated (dead reckoning) mode, or 63 if the positioning system is inoperative)
Special manoeuvre indicator: blue sign	2	Indication if blue sign is set ³⁾ 0 = not available = default, 1 = not engaged in special manoeuvre = blue sign not set 2 = engaged in special manoeuvre = blue sign is set 3 is not used
Spare	3	Not used. Should be set to zero. Reserved for future use.
RAIM-flag	1	Receiver autonomous integrity monitoring (RAIM) flag of electronic position fixing device; 0 = RAIM not in use = default; 1 = RAIM in use. RAIM-flag should be determined in accordance with REF#ITU-R1371
Communication state	19	Communication state should be determined in accordance with REF#ITU-R1371
Total	168	Occupies one slot
<p>¹⁾ Not applicable within the Member States for the purpose of this Standard.</p> <p>²⁾ Knots shall be calculated in km/h by external on-board equipment.</p> <p>³⁾ Shall only be evaluated if the report is coming from an Inland AIS mobile station and if the information is derived by automatic means (direct connection to switch).</p>		

2. Ship static and voyage related data (Message 5)

Table II-4
Ship static and voyage related data

Parameter	Bits	Description
Message ID	6	Identifier for this message 5
Repeat indicator	2	Sent by the repeater to indicate how many times a message has been repeated 0-3; Default = 0; 3 = do not repeat any more
User ID (MMSI)	30	MMSI number
AIS version indicator	2	0 = Station compliant with ITU-R M.1371-1; 1 = Station compliant with ITU-R M.1371-3 (or later), 2 = Station compliant with ITU-R M.1371-5 (or later), 3 = Station compliant with future editions
IMO number	30	0 = not available = default — not applicable to Search And Rescue aircraft 0000000001-0000999999 not used 0001000000-0009999999 = valid IMO number; 0010000000-1073741823 = official flag state number. ¹⁾
Call sign	42	7 x 6 bit ASCII characters, '@@@@@@' = not available = default Craft associated with a parent vessel, should use 'A' followed by the last 6 digits of the MMSI of the parent vessel. Examples of these craft include towed vessels, rescue boats, tenders, lifeboats and liferafts
Name	120	Maximum 20 characters 6 bit ASCII, see REF#ITU-R1371; @@@@@@@@@@@@@@@@@@@@ = not available = default. For Search And Rescue (SAR) aircraft, it should be set to 'SAR AIRCRAFT NNNNNNN' where NNNNNNN equals the aircraft registration number
Type of vessel and cargo	8	0 = not available or no vessel = default; 1 — 99 = as defined in REF#ITU-R1371 ²⁾ ; 100 — 199 = preserved, for regional use; 200 — 255 = preserved, for future use Not applicable to SAR aircraft
Overall dimensions of vessel/convoy and reference for position	30	Reference point for reported position; Also indicates the dimension of vessel in metres (see REF#ITU-R1371). For SAR aircraft, the use of this field may be decided by the responsible administration. If used it should indicate the maximum dimensions of the craft. As default should A = B = C = D be set to '0' ^{3) 4) 5)}

Parameter	Bits	Description
Type of electronic position fixing device	4	0 = Undefined (default), 1 = GPS, 2 = GLONASS, 3 = Combined GPS/GLONASS, 4 = Loran-C, 5 = Chayka, 6 = Integrated Navigation System, 7 = surveyed, 8 = Galileo 9 — 14 = not used 15 = internal GNSS
ETA	20	ETA; MMDDHHMM UTC Bits 19 — 16: month; 1 — 12; 0 = not available = default; Bits 15 — 11: day; 1 — 31; 0 = not available = default; Bits 10 — 6: hour; 0 — 23; 24 = not available = default; Bits 5 — 0: minute; 0 — 59; 60 = not available = Default For SAR aircraft, the use of this field may be decided by the responsible administration
Maximum present static draught	8	in 1/10 m, 255 = draught 25,5 m or greater, 0 = not available = default ⁶⁾
Destination	120	Maximum 20 characters using 6-bit ASCII; @@@@ = not available. ⁷⁾
Data Terminal Equipment (DTE)	1	Data terminal ready (0 = available, 1 = not available = default)
Spare	1	Spare. Not used. Shall be set to zero. Reserved for future use
Total	424	Occupies two slots
<p>1) Shall be set to 0 for inland vessels.</p> <p>2) Best applicable vessel type shall be used for inland navigation (see Annex 10).</p> <p>3) The dimensions shall be set to the maximum rectangle size of the convoy.</p> <p>4) The decimetre accuracy of the inland information shall be rounded upwards.</p> <p>5) The reference point information has to be taken out of the SSD interface sentence by distinguishing the field 'source identifier'. Position reference point information with source identifier AI, has to be stored as internal one. Other source identifiers shall lead to reference point information for the external reference point.</p> <p>6) The centimetre accuracy on the inland information shall be rounded upwards.</p> <p>7) The ISRS Location Codes as part of the RIS Index shall be used derived from the ERDMS kept by the European Commission.</p>		

Figure II-1
Reference point for reported position and overall dimension of vessel/convoy

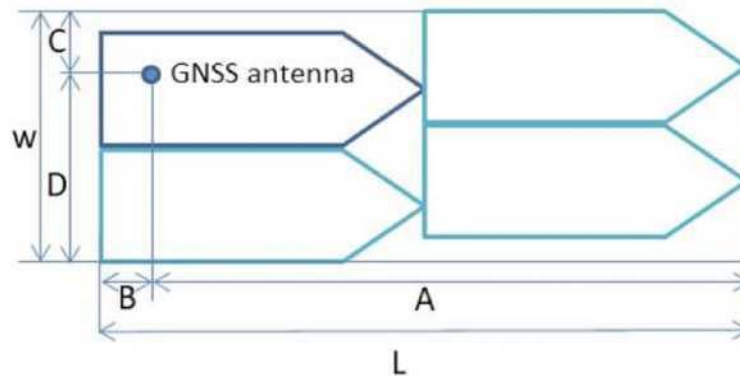

	Bits	Bit fields	Distance (m)	
A	9	Bit 21 — Bit 29	0 — 511 511 = 511 m or greater	Reference Point for reported position
B	9	Bit 12 — Bit 20	0 — 511 511 = 511 m or greater	
C	6	Bit 6 — Bit 11	0 — 63 63 = 63 m or greater	
D	6	Bit 0 — Bit 5	0 — 63 63 = 63 m or greater	
L = A + B	Defined in Inland FI 10			Overall dimension used in Inland AIS mobile station
W = C + D				
<p>The dimension should be in the direction of the transmitted heading information (bow).</p> <p>Reference point of reported position not available, but dimensions of vessel/convoy are available: A = C = 0 and B * 0 and D * 0.</p> <p>Neither reference point of reported position nor dimensions of vessel/convoy are available: A = B = C = D = 0 (= default).</p> <p>For use of the message table, A = most significant field. D = least significant field.</p>				

3. Group assignment command (Message 23)

Inland AIS mobile stations shall be addressed for group assignment by Message 23 using station type '6 = inland waterways'.

4. Information content through Application Specific Messages of the International Function Messages (IFM) branch

The following messages of the IFM branch are also applicable in inland navigation and shall comply with REF#ITU-R1371:

- a) IFM 0 – Text telegram 6-bit ASCII (Msg 6 or 8, DAC=001, FI=0);
- b) IFM 2 – Interrogation on specific functional message (Msg 6 or 8, DAC=001, FI=2);
- c) IFM 3 – Capability Interrogation (DAC=001, FI=3);
- d) IFM 4 – Capability response (DAC=001, FI=4);
- e) IFM 5 – Application acknowledgement to an addressed binary message (DAC=001, FI=5);

The following message of the IFM branch is also applicable in inland navigation and shall comply with the IMO SN.1/Circ.289:

- f) IFM 16 – Persons on board message (DAC=001, FI=16).

This information content of these messages is normally handled by an external application, such as Inland ECDIS.

Article 3.05 ***Inland AIS Application Specific Messages***

1. Inland AIS Application Specific Messages

- a) To comply with the information needs for Inland AIS, Inland AIS Application Specific Messages are defined:
 - Information content implemented directly in the Inland AIS mobile station through Application Specific Messages;
 - Information content provided by external applications and sent by the Inland AIS mobile station or AIS base station through Application Specific Messages. These Application Specific Messages are normally handled by an external application, such as VTS systems or Inland ECDIS.
- b) The use of Inland AIS ASM provided by external applications is in the responsibility of the river commission or the competent authorities.

2. Application identifier for Inland AIS Application Specific Messages
 - a) The application specific messages consist of the AIS Class A mobile stations framework according REF#ITU-R1371 (message ID, repeat indicator, source ID, destination ID), the Application Identifier (AI = DAC + FI) and the data content (variable length up to a given maximum).
 - b) The 16-bit application identifier (AI = DAC + FI) consists of the following elements:
 - i) 10-bit designated area code (DAC): international (DAC = 1) or regional (DAC > 1);
 - ii) 6-bit function identifier (FI) — allows for 64 unique application specific messages.
 - c) For the European harmonised Inland AIS Application Specific Messages the DAC '200' is used.
 - d) In addition national (regional) DAC may be used in local ASM e.g. test pilots. Nevertheless it is strongly recommended to avoid the usage of regional ASM.
 - e) An overview of all Inland AIS specific messages is given in Table 15-3 Chapter 1 of Annex 15.

3. Information content implemented directly in the Inland AIS station through Application Specific Messages

Inland AIS ASM DAC = 200 FI = 10 (Inland Ship static and voyage related data) and DAC = 200 FI = 55 (inland number of persons on board) are sent from the Inland AIS station and shall be implemented directly in the Inland AIS station (see (a) and (b)).

- a) Inland ship static and voyage related data (Inland specific Message FI 10)

This message shall be sent by Inland AIS mobile stations, to broadcast vessel static and voyage related data in addition to message 5. The message shall be sent with binary message 8 as soon as possible (from the AIS point of view) after message 5.

**Table II-5
Inland vessel data report**

Parameter		Bits	Description
Message ID		6	Identifier for message 8; always 8
Repeat indicator		2	Used by the repeater to indicate how many times a message has been repeated. 0 — 3; Default = 0; 3 = do not repeat any more
Source ID		30	MMSI number
Spare		2	Not used, shall be set to zero. Reserved for future use
Binary data	Application identifier	16	DAC = 200, FI = 10
	Unique European vessel identification number (ENI)	48	8*6 Bit ASCII characters 00000000 = ENI not assigned = default

Parameter	Bits	Description
Length of vessel/convoy	13	1 — 8 000 (rest not to be used) length of vessel/convoy in 1/10 m; 0 = default
Beam of vessel/convoy	10	1 — 1 000 (rest not to be used) beam of vessel/convoy in 1/10 m; 0 = default
Vessel and convoy type	14	Numeric vessel and convoy type as described in Annex 10 0 = not available = default
Dangerous cargo indication	3	Number of blue cones/lights 0 — 3; 4 = B-Flag, 5 = default = unknown
Maximum present static draught	11	1 — 2 000 (rest not used) draught in 1/100 m, 0 = default = unknown
Loaded/unloaded	2	1 = loaded, 2 = unloaded, 0 = not available/default, 3 shall not be used
Quality of speed information	1	1 = high, 0 = low/GNSS = default (*)
Quality of course information	1	1 = high, 0 = low/GNSS = default (*)
Quality of heading information	1	1 = high, 0 = low = default (*)
Spare	8	Not used, shall be set to zero. Reserved for future use
Total	168	Occupies one slot
(*) Shall be set to 0 if no type approved sensor (e.g. gyro) is connected to the transponder.		

b) Number of persons on board (Inland specific message FI 55)

This message shall be sent by Inland AIS mobile stations, to inform about the number of persons (passengers, crew, shipboard personnel) on board. The message shall be sent with binary message 6 preferably on event or on request using International Application Identifier binary functional message 2.

Table II-6
Number of persons on board report

Parameter	Bits	Description
Message ID	6	Identifier for message 6; always 6
Repeat indicator	2	Used by the repeater to indicate how many times a message has been repeated. 0 — 3; Default = 0; 3 = do not repeat any more
Source ID	30	MMSI number of source station
Sequence number	2	0 — 3

Parameter	Bits	Description	
Destination ID	30	MMSI number of destination station	
Repeater flag	1	Repeater flag shall be set upon retransmission: 0 = no retransmission = default; 1 = retransmitted.	
Spare	1	Not used, shall be set to zero. Reserved for future use	
Binary data	Application identifier	16	DAC = 200, FI = 55
	Number of crew members on board	8	0 — 254 crew members, 255 = unknown = default
	Number of passengers on board	13	0 — 8 190 passengers, 8 191 = unknown = default
	Number of shipboard personnel on board	8	0 — 254 shipboard personnel, 255 = unknown = default
	Spare	51	Not used, shall be set to zero. Reserved for future use.
Total	168	Occupies one slot	

4. Information content provided by external applications and sent by Inland AIS mobile station or AIS base stations through Application Specific Messages
- a) Convoy Message (Inland specific message (FI 11))
 - i) The convoy message shall be sent from vessel to shore to notify the shape of a convoy and the ID and loading status of the barges.
 - ii) The details of the structure, additional information and usage notes of this message are given in Annex 15 (2.1).
 - b) Inland Capability reply from external application (Inland specific message FI 4)
 - i) The Inland Capability Interrogation reply from external application shall be used by an application connected to the Inland AIS station to reply (using Message 6) to an Inland Capability Interrogation (DAC 200, FI 32) function message. The reply contains the availability status of the application for each function identifier in the Inland AIS ASM branch (DAC 200) or other DAC. An Inland AIS station answers to an interrogation by ITU 1371 IFM 3 using IFM 4.
 - ii) The details of the structure, additional information and usage notes of this message are given in Annex 15 (2.2).
 - c) ETA message (Inland specific message FI 21)
 - i) The ETA message shall be sent from vessel to shore (lock, openable bridge or terminal) to notify that the vessel is heading towards the object and desires handling (locking, passing, berthing, transshipment, etc.) at the submitted date and time
 - ii) The details of the structure, additional information and usage notes of this message are given in Annex 15 (2.3).

-
5. Optional information content/request sent from Inland AIS shore station through Application Specific Messages
- a) Control Message (Inland specific message (FI 1)
 - i) The Control message shall be sent by the competent authority from shore only to allow or forbid the broadcasting of ASM by vessels navigating in a geographical area under their jurisdiction.
 - ii) The details of the structure, additional information and usage notes of this message are given in Annex 15(3.1).
 - b) Inland Capability Interrogation to external application (Inland specific message FI 3)
 - i) The Inland Capability Interrogation to external application shall be used to interrogate on-board applications connected to the Inland AIS station for the availability of Inland AIS ASM (DAC 200) or other DAC. If the Inland AIS station shall be interrogated ITU 1371 IFM3 shall be used.
 - ii) The details of the structure, additional information and usage notes of this message are given in Annex 15(3.2).
 - c) Requested Time of Arrival (RTA) message (Inland specific message FI 22)
 - i) The RTA message shall be sent as answer to a previously received ETA message (Inland ASM FI 21) from shore to the vessel to confirm the requested time of arrival, or to propose a different schedule.
 - ii) The details of the structure, additional information and usage notes of this message are given in Annex 15(3.3).
 - d) Present Bridge Clearance message (Inland specific message FI 25)
 - i) This message shall be sent from shore to inform dynamically about the actual minimum vertical clearance of a certain bridge opening. The information is meant to be displayed on an external display such as Inland ECDIS.
 - ii) The details of the structure, additional information and usage notes of this message are given in Annex 15(3.4).
 - e) Water Level message (Inland specific message FI 26)
 - i) This message shall be used to inform boatmasters about actual water levels in their area. It is additional short term information to the water levels distributed via Notices to Skippers. The update rate shall be defined by the competent authority. It is possible to transmit the water levels of more than 3 gauges using multiple messages.
 - ii) The details of the structure, additional information and usage notes of this message are given in Annex 15(3.5).

-
- f) Signal Station message (Inland specific message FI 41)
 - i) This message shall be sent from a competent authority to inform about the status of different light signals at traffic signal stations to all vessels in a certain area. The information shall be displayed on an external display such as Inland ECDIS application as dynamic symbols. This message is an updated version of the "Signal status message" (FI 40) which cannot be updated due to the lack of a version indicator.
 - ii) The details of the structure, additional information and usage notes of this message are given in Annex 15(3.6).
 - g) Geographic Notice (Inland specific message FI 42)
 - i) The purpose of the Geographic Notice is to transmit information that pertains to a region or area, for example a security zone, an area of fog, or dredging operations. The areas that are being defined can be circles, rectangles, polygons, or sectors. They can also be defined as a simple point or series of points (polyline). The Geographic Notice message can be made up of multiple subareas in which case the total area is the unionsum of the subareas. This message can also be used to convey advisory lines or tracks (using the polyline subarea); however, the Route Information message should be used for recommended or directed routes.
 - ii) The details of the structure, additional information and usage notes of this message are given in Annex 15(3.7).
 - h) ISRS Text message (Inland specific message FI 44)
 - i) The ISRS Text message can be used to transmit free text information which is related to any object which has an ISRS Location Code.
 - ii) The details of the structure, additional information and usage notes of this message are given in Annex 15(3.8).

CHAPTER 4

OTHER AIS MOBILE STATIONS ON INLAND WATERWAYS

Article 4.01 **Introduction**

1. Vessels not obliged to operate Inland AIS mobile stations may use other AIS mobile stations. The following mobile stations can be used:
 - a) AIS Class A mobile station in accordance with Articles 35(2) and 35(3) of REF#EU-201490;
 - b) AIS Class B mobile station in accordance with Part II, Article 4.02.
2. The use of such stations in inland waterways is up to the decision of the Competent Authority responsible for the navigation in that area.
3. If such stations are used on a voluntary basis, the shipmaster shall keep the manually entered AIS data constantly up to date. No incorrect data shall be transmitted over AIS.

Article 4.02 **General requirements for AIS Class B mobile stations on inland waterways**

1. AIS Class B has restricted functionalities compared to Inland AIS mobile stations. The messages sent out by an AIS Class B mobile station are transmitted with a lower priority in comparison to Inland AIS mobile stations.
2. AIS Class B mobile stations installed on vessels navigating on Union inland waterways shall meet the requirements set out in:
 - a) REF#ITU-R1371,
 - b) REF#IEC-62287 (including DSC channel management).

Note: It is the responsibility of the Competent Authority responsible for the navigation in that area to ascertain the conformity of AIS Class B mobile stations to the standards and requirements listed in the second subparagraph prior to issuing a ship station license, assigning a MMSI number, for example by type approval of the relevant AIS Class B mobile stations.

CHAPTER 5

AIS AIDS TO NAVIGATION IN INLAND NAVIGATION

Article 5.01

Introduction

1. A list of types of AtoNs is included in Table II-8.
2. The AIS technology provides the possibility to dynamically transfer information about AtoNs.
3. For the use in inland navigation the maritime AIS AtoN report (Message 21) needs to be extended to reflect the specifics of the inland buoyage system.
4. The maritime AIS AtoN report is based on the IALA buoyage system as defined in REF#IALA-R0126:

“An AIS AtoN can be implemented in three ways, Physical, Synthetic, and Virtual. For Virtual AIS AtoN reference should be made to REF#IALA-R0143, and to REF#IALA-G1081.

a) Physical AIS AtoN

A Physical AIS AtoN Station is an AIS station located on an AtoN that physically exists.

b) Synthetic AIS AtoN

A Synthetic AIS AtoN is where Message 21 is transmitted from an AIS station located remotely from the AtoN. REF#IEC-62320-2 states that ‘for Synthetic AIS AtoN messages, the repeat indicator field shall be set to 1, 2, or 3 to signify that the message is transmitted from a position other than that provided in the message’. There are 2 types of Synthetic AIS AtoN, ‘Monitored Synthetic AIS AtoN’ and ‘Predicted Synthetic AIS AtoN’.

i) Monitored Synthetic AIS AtoN

- A ‘Monitored Synthetic AIS AtoN’ is transmitted as a message 21 from an AIS Station that is located remotely from the AtoN. The AtoN physically exists and there is a communication link between the AIS Station and the AtoN. The communication between the AtoN and AIS confirms the location and status of the AtoN.
- A Monitored Synthetic AIS AtoN ensures the integrity of the Message 21.

- ii) Predicted Synthetic AIS AtoN
 - A 'Predicted Synthetic AIS AtoN' is transmitted as a Message 21 from an AIS Station that is located remotely from the AtoN. The AtoN physically exists but the AtoN is not monitored to confirm its location or status.
 - A Predicted Synthetic AIS AtoN does not ensure the integrity of the Message 21, and therefore is not recommended for use on floating AtoN.
 - The use of Predicted Synthetic AIS AtoN broadcasts for fixed AtoN is acceptable as the location will not change, but the status of the AtoN is not verified.
 - c) Virtual AIS AtoN
 - i) A 'Virtual AIS AtoN' is transmitted as a Message 21 for an AtoN that does not physically exist.
 - ii) When a Virtual AIS AtoN is used, the AtoN symbol or information would be available for presentation to a boatmaster, even though there is no physical AtoN such as a buoy or beacon. A base station or AtoN station would broadcast this message.
 - iii) The 'Virtual AtoN Flag' in Message 21 would be set to 1, to clearly identify this as a Virtual AIS AtoN."
5. For inland navigation the AIS AtoN report needs to reflect the European Inland AtoN system described in Part II, Chapter 5.
6. The AIS AtoN report transfers the position and the meaning of the AtoN as well as information if a buoy is on the required position (on position) or not (off position).

Article 5.02
Use of Message 21: Aids to Navigation report

1. For the use on inland waterways the AIS AtoN report (Message 21) as defined in REF#ITU-R1371 is being used. The additional European Inland types of AtoN are coded using the 'AtoN status' bits.

Table II-7
AIS AtoN Report

Parameter	Bits	Description
Message ID	6	Identifier for this message 21
Repeat indicator	2	Used by the repeater to indicate how many times a message has been repeated 0-3; Default = 0; 3 = do not repeat any more
ID	30	MMSI number, (see Article 19 of the Radio Regulations (RR) and REF#ITU-R585)
Type of Aids-to- Navigation	5	0 = not available = default; refer to appropriate definition set up by IALA; see Figure II-2 ¹⁾
Name of Aids-to- Navigation	120	Maximum 20 characters 6-bit ASCII, as defined in Table 47 '@@@@@@@@@@@@@@@@@@@@@@@@@@@@@@' = not available = default. The name of the AtoN may be extended by the parameter 'Name of Aids-to-Navigation Extension' below
Position accuracy (PA)	1	1 = high (< 10 m) 0 = low (> 10 m) 0 = default. The PA flag should be determined in accordance with REF#ITU-R1371 table 'Determination of position accuracy information'
Longitude	28	Longitude in 1/10 000 min of position of an AtoN ($\pm 180^\circ$, East = positive, West = negative 181 = (6791AC0h) = not available = default)
Latitude	27	Latitude in 1/10 000 min of an AtoN ($\pm 90^\circ$, North = positive, South = negative 91 = (3412140h) = not available = default)
Dimension / refe- rence for position	30	Reference point for reported position; also indicates the dimension of an AtoN (m) (see Figure II-2), if relevant ²⁾

Parameter	Bits	Description
Type of electronic position fixing device	4	0 = Undefined (default) 1 = GPS 2 = GLONASS 3 = Combined GPS/GLONASS 4 = Loran-C 5 = Chayka 6 = Integrated Navigation System 7 = surveyed. For fixed AtoN and virtual AtoN, the charted position should be used. The accurate position enhances its function as a radar reference target 8 = Galileo 9-14 = not used 15 = internal GNSS
Time stamp	6	UTC second when the report was generated by the EPFS (0-59 or 60) if time stamp is not available, which should also be the default value or 61 if positioning system is in manual input mode or 62 if electronic position fixing system operates in estimated (dead reckoning) mode or 63 if the positioning system is inoperative)
Off-position indicator	1	For floating AtoN, only: 0 = on position; 1 = off position. NOTE 1 — This flag should only be considered valid by receiving station, if the AtoN is a floating aid, and if time stamp is equal to or below 59. For floating AtoN the guard zone parameters should be set on installation
AtoN status	8	Reserved for the indication of the AtoN status 00000000 = default ³⁾
RAIM-flag	1	RAIM (Receiver autonomous integrity monitoring) flag of electronic position fixing device; 0 = RAIM not in use = default; 1 = RAIM in use; see REF#ITU-R1371 table 'Determination of position accuracy information'
Virtual AtoN flag	1	0 = default = physical AtoN at indicated position; 1 = virtual AtoN, does not physically exist ⁴⁾
Assigned mode flag	1	0 = Station operating in autonomous and continuous mode = default 1 = Station operating in assigned mode
Spare	1	Spare. Not used. Should be set to zero. Reserved for future use
Name of Aids-to- Navigation Extension	0, 6, 12, 18, 24, 30, 36, 42, 48, 54, 60, 66, 72, 78, 84	This parameter of up to 14 additional 6-bit-ASCII characters for a 2-slot message may be combined with the parameter 'Name of Aids-to-Navigation' at the end of that parameter, when more than 20 characters are needed for the name of the AtoN. This parameter should be omitted when no more than 20 characters for the name of the AtoN are needed in total. Only the required number of characters should be transmitted, i.e. no @-character should be used

Parameter	Bits	Description
Spare	0, 2, 4, or 6	Spare. Used only when parameter 'Name of Aids-to-Navigation Extension' is used. Should be set to zero. The number of spare bits should be adjusted in order to observe byte boundaries
Total	272-360	Occupies two slots
<p>1) In case an inland AtoN type code is being transmitted, this field (type of AtoN) shall be set to 0 = undefined.</p> <p>2) When using Figure II-2 for AtoN the following shall be observed:</p> <ul style="list-style-type: none"> - For fixed AtoN, virtual AtoN, and for offshore structures, the orientation established by the dimension A shall point to true north. - For floating aids larger than 2 m x 2 m the dimensions of the AtoN shall always be given approximated to a circle, i.e. the dimensions shall always be as follows $A = B = C = D * 0$. (This is due to the fact that the orientation of the floating AtoN is not transmitted. The reference point for reported position is in the centre of the circle.) - $A = B = C = D = 1$ shall indicate objects (fixed or floating) smaller than or equal to 2 m x 2 m. (The reference point for reported position is in the centre of the circle.) - Floating offshore structures that are not fixed, such as rigs, shall be considered as Code 31 type from Table II-8. These structures shall have their 'Dimension/reference for position' parameter as determined above in Note (1). - For fixed offshore structures, Code 3 type from Table II-8, shall have their 'Dimension/reference for position' parameter as determined above in Note (1). Hence, all offshore AtoN and structures have the dimension determined in the same manner and the actual dimensions are contained in Message 21. <p>3) For Inland AIS AtoN report this field shall be used to indicate the Inland AtoN type using page 001</p> <p>4) When transmitting virtual AtoN information, i.e. the virtual/pseudo AtoN Target Flag is set to one (1), the dimensions shall be set to $A = B = C = D = 0$ (default). This shall also be the case, when transmitting 'reference point' information.</p>		

Figure II-2
Reference point for reported position of a maritime AtoN, or the dimension of an AtoN

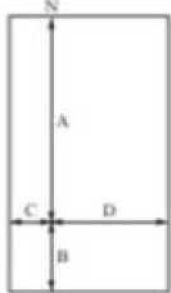
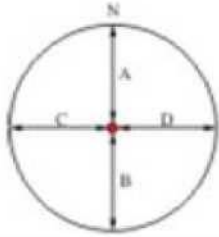
	Bits	Bit Fields	Distance (m)
	A	Bit 21 — Bit 29	0-511 511 — 511 m or greater
	B	Bit 12 — Bit 20	0-511 511 — 511 m or greater
	C	Bit 6 — Bit 11	0-63 63 — 63 m or greater
	D	Bit 0 — Bit 5	0-63 63 — 63 m or greater

2. If the type of AtoN to be transmitted is covered within the existing IALA types of AtoN (according to Table II-8) no changes need to be applied.

Table II-8
Types of Aids to Navigation

Code	Definition Maritime	
0	Default, Type of AtoN not specified	
1	Reference point	
2	RACON	
3	Fixed structures offshore, such as oil platforms, wind farms. (NOTE 1 — This code should identify an obstruction that is fitted with an AtoN AIS station)	
4	Emergency Wreck Marking Buoy	
Fixed AtoN	5	Light, without sectors
	6	Light, with sectors
	7	Leading Light Front
	8	Leading Light Rear
	9	Beacon, Cardinal N
	10	Beacon, Cardinal E
	11	Beacon, Cardinal S
	12	Beacon, Cardinal W
	13	Beacon, Port hand

Code	Definition Maritime	
14	Beacon, Starboard hand	
15	Beacon, Preferred Channel port hand	
16	Beacon, Preferred Channel starboard hand	
17	Beacon, Isolated danger	
18	Beacon, Safe water	
19	Beacon, Special mark	
Floating AtoN	20	Cardinal Mark N
	21	Cardinal Mark E
	22	Cardinal Mark S
	23	Cardinal Mark W
	24	Port hand Mark
	25	Starboard hand Mark
	26	Preferred Channel Port hand
	27	Preferred Channel Starboard hand
	28	Isolated danger
	29	Safe Water
	30	Special Mark
	31	Light Vessel/LANBY/Rigs

Note 1 The types of AtoN listed above are based on the IALA Maritime Buoyage System, where applicable.

Note 2 There is potential for confusion when deciding whether an aid is lighted or unlighted. Competent authorities may wish to use the regional/local section of the message to indicate this.

Article 5.03 **Extension of Message 21 with inland-specific type of AtoN**

1. The parameter field 'AtoN status' is used for the extension of Message 21 with inland-specific type of AtoN.
2. The parameter field 'AtoN status' is organised in eight pages, of which page ID 0 is 0 = default, page ID 1 to 3 is for regional use and page ID 4 to 7 is for international use. The first three bits of the AtoN status field defines the page ID, the remaining 5 bits contains the information of the page.



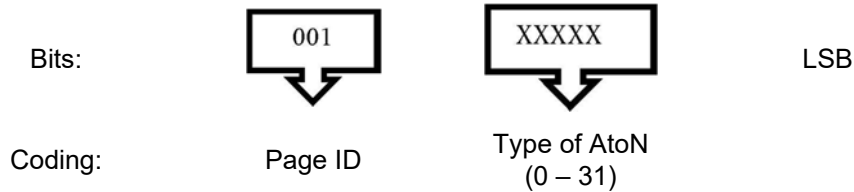











3. The region, in which page ID 1 to 3 is applicable is defined by the Maritime Identification Digits within the MMSI of the transmitting AIS AtoN station. Thus the bit coding of the 5 information bits in the AtoN status field is only applicable in this specific region.
4. As regards Union inland waterways page ID 1 of the AtoN status field contains the list of inland-specific type of AtoN used.







5. Setting an inland-specific type of AtoN in Message 21 is a two-step process:
 - a) First the parameter 'Type of aids-to-navigation' in Message 21 needs to be set to '0 = Default, type of AtoN not specified'.
 - b) Second, the parameter 'AIS status' needs to be set to page ID 1 and the appropriate code of the inland-specific type of AtoN.
6. This will result that the AtoN status field will start with binary "001" followed by the binary code defined in Table II-9.

7. This table provides all types of Inland AtoN for use in AtoN status bits.

Table II-9
Types of Inland Aids to Navigation

	Inland AtoN Code	AtoN status bits in AIS Message 21	Associated marking sign	Name
	0	00100000		Default, Type not specified
fixed aids, landmarks	1	00100001		Channel near the right bank
	2	00100010		Channel near the left bank
	3	00100011		Crossover right bank
	4	00100100		Crossover left bank
	5	00100101		Bridge pier
	6	00100110		Overhead cable
floating aids	7	00100111		right-hand side of the fairway
	8	00101000		left-hand side of the fairway
	9	00101001		Bifurcation of the fairway
	10	00101010		Bifurcation, pass right-hand side
	11	00101011		Bifurcation, pass left-hand side
	12	00101100		Danger point and obstacle right-hand side
	13	00101101		Danger point and obstacle left-hand side
	14	00101110		Berth right-hand side
	15	00101111		Berth left-hand side

	Inland AtoN Code	AtoN status bits in AIS Message 21	Associated marking sign	Name
Other	16	00110000		No entry *
	17	00110001		Do not create wash*
	18	00110010		Headroom limited
	19	00110011		Signal float
Reserved	20	00110100		Reserved for future use
	21	00110101		Reserved for future use
	22	00110110		Reserved for future use
	23	00110111		Reserved for future use
	24	00111000		Reserved for future use
	25	00111001		Reserved for future use
	26	00111010		Reserved for future use
	27	00111011		Reserved for future use
	28	00111100		Reserved for future use
	29	00111101		Reserved for future use
	30	00111110		Reserved for future use
	31	00111111		Reserved for future use

* For Inland AIS AtoN report the parameter "Name of Aids to Navigation" may be used to transmit the direction of impact of the AtoN. This information may be transmitted with or without preceding name value. In this case the content of the parameter contains two percent symbols '%' directly followed by the direction of impact in full degrees clockwise, between 0° to 359°, starting from North, presented always in three digits e.g. %%270 for direction of impact 270 degrees or %%030 for direction of impact 30 degrees.

8. The symbols shown in this table are used for unambiguous identification of the type of AtoN and do not suggest the visualisation of applicable symbols to Inland AIS AtoN in Inland ECDIS displays.

9. The design of notice marks and buoys, which has to be used at specific Inland Waterways, is prescribed in the applicable police regulation in this area.
10. The following MID are used for the transmission of Inland AtoN information in the coding of page 1 of the AtoN status bits in AIS message 21 in Europe:

Table II-10
List of applicable MIDs for Inland AIS AtoN report message (AIS message 21)

MID	Country
203	Austria
205	Belgium
207	Bulgaria
218	Germany
214	Moldova
226	France
238	Croatia
243	Hungary
246	The Netherlands
247	Italy
253	Luxembourg
261	Poland
264	Romania
267	Slovak Republic
269	Switzerland
270	Czech Republic
272	Ukraine
273	Russian Federation
279	Serbia

PART III NOTICES TO SKIPPERS

CHAPTER 1 GENERAL PROVISIONS

Article 1.01 Definitions

Definitions are given in Part 0, Chapter 2.

Article 1.02 Primary functions and performance requirements for Notices to Skippers (NtS)

1. This technical specification for NtS provides rules for the data transmission of fairway information via Internet.
2. NtS shall:
 - a) provide information related to fairway conditions, traffic, weather, water levels and ice for Fairway Information Services;
 - b) provide automatic translation of the most important content of notices, using standard vocabulary based on code lists (the NtS Reference Tables as provided in Annex 32);
 - c) be provided in a standardised structure of data-sets to facilitate the integration of notices in voyage planning systems;
 - d) be compatible with the data-structure of the RIS Index and ES-RIS, Part I to facilitate integration of NtS into Inland ECDIS (Part I).
3. The technical specifications for NtS facilitate the data-exchange among NtS systems of different countries and towards other applications making use of NtS data, including Inland ECDIS (Part I).
4. Some information contained within NtS messages can be standardised, some cannot.
5. The standardised part shall cover all the information which is:
 - a) important for the safety of inland navigation (for example: sunken small craft on the right side of the fairway at the Danube, river-km 2010);
 - b) needed for voyage planning including closure of locks and reduction of vertical clearance.
6. Additional information that is not relevant for safety or voyage planning, including the cause of the closure of a lock, may be given as free text, without automatic translation. The use of free text shall be restricted to a minimum.

CHAPTER 2
PROVISION OF NOTICES TO SKIPPERS

1. Member States shall ensure that NtS messages are accessible online and via standardised NtS web service, in accordance with the technical specifications described in this Part and Annexes 28 to 32.
2. The standardised NtS web service specification is included in Annex 31 in the form of a WSDL.
3. The standardised NtS web services shall provide the user with the possibility to select messages on the grounds of at least one of the following criteria:
 - a) a specific country,
 - b) time of validity of the notice (start date and end date of validity period),
 - c) date of publication of the notice (date and time of publication).
4. NtS messages that comply with the standards referred to in this Part can be provided, among other tools, by:
 - a) mobile applications (apps),
 - b) E-mail services.
5. Data exchange among the NtS systems operated in different countries may be carried out. All systems using the standards described in this Part may integrate NtS of other systems in their own services, provided the content of the message is not modified. Users shall be informed in case the connection to a source of integrated NtS is interrupted or not available.

CHAPTER 3

NTS MESSAGE TYPES

1. NtS messages are essential messages that are standardised to the highest part possible.
2. There are three NtS message types, namely:
 - a) fairway and traffic related message,
 - b) water related message,
 - c) weather related message.

CHAPTER 4

STRUCTURE OF NTS AND ENCODING OF NTS MESSAGES

1. This Chapter describes the structure and encoding of standardised electronic NtS messages.
2. An NtS message is a structured message using standardised elements, wherever possible. The use of free text in the data elements shall be restricted to a minimum.
3. The standardised NtS extended markup language (XML) schema definition, referred to as XSD in this Part, contains the standardised code values and possible formats is included in Annex 30.
4. The standardised code values and the XML tags, their meaning and translation are provided in the NtS Reference Tables in Annex 32 and are also available electronically in the ERDMS operated by the European Commission.

Article 4.01

General structure

An NtS message consists of the following sections:

- a) identification section;
- b) section defining the applicable object(s) or fairway section(s) the message is related to;
- c) limitation(s) for a fairway and traffic related message, measurement(s) for a water related message or weather report(s) for a weather related message.

Figure III-1
Notice to Skippers message structure

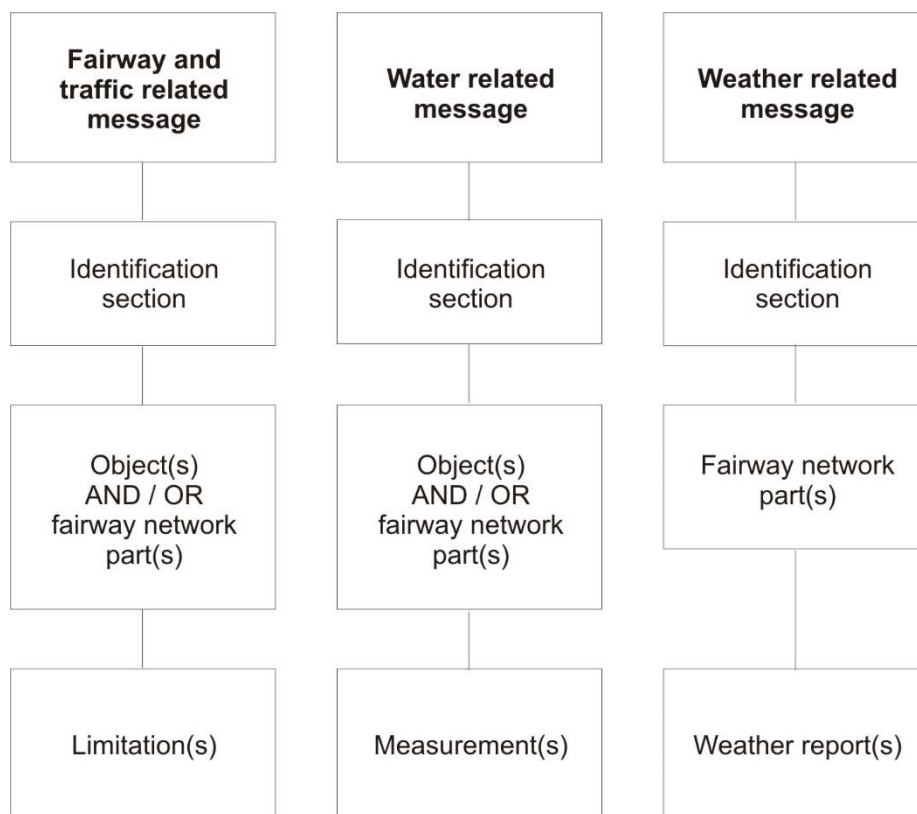

1. Identification section

Each message must contain an identification section. The identification section contains general information about the issuer and date of publication of the message.

2. Fairway and traffic related message

The fairway and traffic related message contains information for fairway network part(s) or object(s), and it is used to indicate limitation(s) and ice conditions for the following purposes:

- a) **'Warning'**: relevant for safety. The warning must contain at least one limitation that results in direct and concrete endangerment of persons, crafts or facilities, such as welding works on a bridge producing sparks, inspection cage/workers hanging from a bridge, obstacle in the fairway;
- b) **'Announcement'**: relevant for voyage planning or safety. The announcement may contain limitations, such as blockage of a lock chamber due to maintenance works, dredging on the fairway;
- c) **'Info service'**: general information that is not directly linked to voyage planning or safety. The info service must not contain specific limitations, therefore it is not directly relevant to voyage planning or safety. Such information might include general information such as local rules of traffic, Inland ECDIS Update.

3. Water related message

The water related section contains values or forecasts for:

- a) water level,
- b) least sounded depth,
- c) vertical clearance,
- d) barrage status,
- e) discharge,
- f) regime.

Usually, water related information is created and published automatically based on data received from sensor equipment (such as tide gauge), systems (such as water level model) or infrastructure (such as barrage status). There may be different triggers for publication, such as periodical publication or reaching certain value.

4. Weather related message

The weather related message contains information about (dangerous) weather conditions for inland navigation.

In order to facilitate the distribution of hydro-meteo information from hydro-meteo networks to boatmaster, weather related messages may be published.

Article 4.02

Explanation of XML tags and code values in the NtS Reference Tables

The meaning of the different elements used in the NtS XML schema definition (XSD) is described in the NtS Reference Tables provided in Annex 32. The structure, format and possible values of all XML elements are described in the NtS XSD in Annex 30.

- a) Latitude and longitude coordinates are encoded according to the World Geodetic System 1984 (EPSG:4326) and are presented in degrees with six decimals ([d]d.dddddd (latitude), [d][d]d.dddddd (longitude))
- b) Decimals in numeric fields are indicated with a decimal point ('.'). No separators for thousand are used.
- c) NtS messages shall only use the following units for the values included in the XML message: cm, m³/s, h, km/h and kW, m/s (wind), mm/h (rain) and degree Celsius. National applications may convert the units for user- friendly display.

Article 4.03

Identification of fairway sections and objects in NtS messages

1. To supply to RIS users all relevant data concerning navigation and voyage planning on inland waterways, the ISRS Location Code has to be used. The ISRS Location Code is used to uniquely identify objects and fairway network parts and to ensure interoperable RIS Systems and Services (such as to combine information about infrastructure from the RIS Index, ES-RIS, Part I and V for voyage planning).
2. The ISRS Location Code is a 20-digit alphanumerical code used to establish a unique and standardised relation between objects in River Information Services. It consists of the following mandatory data elements, arranged in four information blocks:
 - a) Block 1: UN/LOCODE (5 letters, alphanumerical), comprising
 - i) Country code (2 digits, alphanumerical as defined in REF#ISO-3166-1 alpha 2), and
 - ii) Location code (3 digits, alphanumerical, 'XXX' if not available);
 - b) Block 2: Fairway section code (5 digits, alphanumerical, to be determined by the national authority);
 - c) Block 3: Object Reference Code (5 digits, alphanumerical, 'XXXXX' if not available);
 - d) Block 4: Fairway section hectometre (5 digits, numerical, hectometre at the centre of the area or '00000' if not available).
3. The ISRS Location Code is created once and shall not be changed throughout the lifetime of the object. The ISRS Location Codes and the reference data of objects are maintained by the Member States in the RIS Index and submitted to the ERDMS operated by the European Commission according to the Maintenance procedures for the RIS Index published on the ERDMS website.

Article 4.04
Rules for encoding of NtS messages

NtS messages shall be encoded in line with the NtS Encoding Guide for editors (Annex 28) and in line with the NtS Encoding Guide for application developers (Annex 29).

PART IV ELECTRONIC SHIP REPORTING IN INLAND NAVIGATION

CHAPTER 1 MESSAGE IMPLEMENTATION MANUAL CONVENTION

Article 1.01 Introduction

These technical specifications define the structure of five ERI messages types for electronic ship reporting in inland navigation:

The ERI messages types are:

- (Dangerous) goods reporting message — ERINOT (Annex 20),
- Passenger and crew lists message — PAXLST (Annex 21),
- ERINOT response and receipt message — ERIRSP (Annex 22),
- Berth management port notification message — BERMAN (Annex 23),
- Voyage Plan Notification message — ERIVOY (Annex 24).

In the case that electronic ship reporting in inland navigation is required by national or international law these technical specifications shall be applied.

The ERI messages ERINOT, PAXLST, ERIRSP and BERMAN can be sent using a structure based on the United Nations rules for Electronic Data Interchange for Administration, Commerce and Transport (UN/EDIFACT)¹ and customised, where required, for the purpose of inland navigation.

The message types ERINOT, PAXLST, ERIRSP and ERIVOY can be sent using a structure based on extensible markup language (XML) that is described using a XML Schema Definition file (XSD).

When the structure of a message is available in both format (UN/EDIFACT and XML) according to this standard, the use of the format XML defined in the corresponding annexes (20, 21, 22) is recommended for this message.

The format to be used is defined in the national or international regulation imposing the reporting formalities.

Both formats are equivalent from a functional point of view and are able to carry the same information.

The exact use of the messages, data elements and codes are defined in the Annexes (Message Implementation Manuals) in order to ensure a common understanding and usage of the messages.

¹ Abbreviations used in this Part are explained in the list in Article 2.05.

Article 1.02

UN/EDIFACT message structure

The message structure is based on ISO 9735.

UN/EDIFACT messages are composed of segments. The structure of a message is described in a branching diagram indicating the position and the mutual relationship of the segments and segment groups.

For each segment data elements are defined: some data elements are combined to form composite data elements. A segment and a data element within a segment are either mandatory (M) or conditional (C). Mandatory segments and/or data elements contain important data for a receiving application and shall be filled with valid data.

Each message starts with two or three segments, the 'interchange header' (UNB) and the 'message header' (UNH). Where required, also the 'service string advice' (UNA) is used as a first segment to define which character sets are used in the message. Each message finishes with the segments 'message trailer' (UNT) and 'interchange trailer' (UNZ). Thus, each message is contained in one interchange, and an interchange contains only one single message.

Article 1.03

XML/XSD message structure

Extensible Markup Language, abbreviated XML, describes a class of data objects called XML documents and partially describes the behaviour of computer programs which process them. XML is an application profile or restricted form of the Standard Generalized Markup Language (SGML) defined by ISO 8879.

The XML is published as a recommendation of the World Wide Web Consortium (W3C) since February 1998.

XML Schema Definition (XSD) is also a recommendation of the W3C since April 2001. XSD are formally XML documents. An XSD file specifies how to formally describe the elements in an XML document. Therefore, an XML document can be validated using a specific XSD file.

Article 1.04

Introduction to message types

As mentioned in Part IV, Article 1.01, the five ERI message types are:

- (Dangerous) goods reporting message — ERINOT,
- Passenger and crew lists message — PAXLST,
- ERINOT response and receipt message — ERIRSP,
- Berth management port notification message — BERMAN,
- Voyage Plan Notification message — ERIVOY.

In addition, messages ERINOT and ERIVROY can fulfil the following functions:

- new message (identifier '9'),
- modification of message (identifier '5'),
- cancellation of message (identifier '1'),
- end of voyage (identifier '22'),
- interruption of voyage (identifier '150'),
- restart of voyage (identifier '151').

1. ERINOT

The ERI notification message (ERINOT) shall be used for the reporting of voyage related information and of information on dangerous and non-dangerous cargo carried on-board vessels sailing on inland waterways. The ERINOT message using UN/EDIFACT format is a specific use of the UN/EDIFACT 'International Forwarding and Transport Dangerous Goods Notification (IFTDGN)' message. This message has also been developed in the XML format.

The ERINOT message encompasses the following types:

- a) transport notification from vessel to authority (identifier 'VES' in both XML and UN/EDIFACT formats), from ship to shore;
- b) transport notification from carrier to authority (identifier 'CAR' in both XML and UN/EDIFACT formats), from shore to shore;
- c) passage notification (identifier 'PAS' in both XML and UN/EDIFACT formats), from authority to authority.

2. PAXLST

The PAXLST message was originally based on the UN/EDIFACT message PAXLST. This message has also been developed in the XML format. It shall be used for the exchange of data in inland navigation between the boatmaster or carrier and designated authorities such as customs, immigration, police or terminals falling under the International Ship and Port Facility Security (ISPS) Code, as defined in REF#EC-2004725.

The message shall be also used to transfer passenger/crew data from a designated authority in the country of departure to the appropriate authorities in the country of arrival of the means of transport.

3. ERIRSP

The ERI response message (ERIRSP) was originally derived from the UN/EDIFACT APERAK message. This message has also been developed in the XML format. It may be generated by the system of the designated authority. The response to a 'modification' or a 'cancellation' contains information whether or not the 'modification' or 'cancellation' has been processed by the receiving system.

4. BERMAN

The Berth Management (BERMAN) message combines the pre-arrival notification, respectively general declaration, into one single notification which is based on the UN/EDIFACT message BERMAN from the UN/EDIFACT D04B directory.

The BERMAN message shall be sent by vessels sailing on inland waterways before arriving at or departing from a berth or a port and provides information about the time of arrival and the services required to ensure a prompt handling, to support procedures and to facilitate controls.

5. ERIVOY

The ERI voyage plan notification message ERIVOY was originally based on the UN/EDIFACT IFTSAI (Transport Scheduling and Information message). This message has also been developed in the XML format. However, only the XML format is part of the standard and can be used for this type of message.

In line with the developments in inland shipping to increasingly use Information and Communication Technologies (ICT) for the exchange of data with authorities and partners, the standardised voyage plan notification message, ERIVOY is meant to be used as a message type from a carrier, its agent or a ship to the responsible waterway authorities and where applicable involved commercial parties or between the waterway authorities mutually, reporting a voyage plan and its particulars and giving details of the voyage, ship, expected voyage details and expected passage of waypoints and other key passage points. It is meant to provide a transport route schedule of a certain ship and its voyage.

The advance availability of routing information will make communication with the involved parties such as the waterway authorities easier and will facilitate handling of certain requests and will ensure easier and safer passages of locks, bridges and other barriers. In this way a better planning of a voyage is feasible. In case of any changes or calamities planning becomes easier and better facilitating vessel traffic services and management. In that way using this message increases the performance and reliability during the voyage of a ship or a convoy.

CHAPTER 2

CODES AND REFERENCES

Article 2.01 **Introduction**

Codes and references, as defined in this Chapter, shall be used in electronic ship reporting for inland navigation. The use of codes and references serves the purpose of unambiguousness: it eliminates the possible misinterpretation and facilitates the translation of messages into other languages.

Therefore the usage of codes and references is mandatory for the data elements indicated in the message implementation manuals. Those codes and references are also available electronically in the ERDMS operated by the Commission.

Those codes and references shall be used whenever data is interchanged between various computer applications and between parties using different languages, even beyond the message types in the subject of this Part.

Article 2.02 **Definitions**

Definitions are given in Part 0, Chapter 2.

Article 2.03 **Classifications and code descriptions**

The following classifications shall be used in inland ship reporting:

1. Vessel and convoy type (REF#UNECE-R28)
2. IMO ship identification number (IMO)
3. Unique European vessel identification number (ENI)
4. Harmonised Commodity Description and Coding System (HS) including Combined Nomenclature
5. Standard goods classification for transport statistics (NST)
6. International maritime dangerous goods code (IMDG)
7. European Agreement concerning the International Carriage of Dangerous Goods by Inland Waterways (ADN)
8. UN country code
9. UN location code (UN/LOCODE)
10. Fairway section code
11. Terminal code
12. Container size and type code
13. Container identification code
14. Package type code
15. Handling instructions

16. Purpose of call
17. Nature of cargo
18. Type of cargo (EUROSTAT)

Article 2.04
Location codes

The ISRS Location Code is defined in Part 0.

Article 2.05
List of abbreviations

Abbreviations are given in Part 0, Chapter 1.

PART V
INLAND ECDIS
OPERATIONAL AND PERFORMANCE REQUIREMENTS,
METHODS OF TEST AND REQUIRED TEST RESULTS
(TEST PART OF INLAND ECDIS)

CHAPTER 1
SCOPE

1. This Part specifies the minimum operational and performance requirements, methods of testing and required test results for Inland ECDIS referring to the Part I. The minimum operational and performance requirements are defined in the Electronic Chart Display and Information System for Inland Navigation Part (Inland ECDIS). This "Test Part" of Inland ECDIS (Part V of ES-RIS refers directly to Part I of ES-RIS (Inland ECDIS). This "Test Part" of Inland ECDIS does not yet contain clauses to test the AIS Application Specific messages.
2. Part I differs between two types of "operational and performance requirements":
 - a) General requirements

These describe general aims and conditions of the individual environment in the wheelhouse, where Inland ECDIS will be used (e.g. "The latest edition of the IENC shall be used.").

These general requirements shall be carefully respected during the installation and operation but cannot be formally tested as part of the certification process of the Inland ECDIS. For this reason, these requirements are not considered in this Test Part of Inland ECDIS.
 - b) Specifications

These are concrete definitions of characteristics concerning the system, its hardware components, the properties and behaviour of the software. All tests shall be completed and the outcome of the tests shall be in conformity with the required test results.

CHAPTER 2

REFERENCES

References are given in Part 0, Chapter 3.

CHAPTER 3 ***ABBREVIATIONS***

Abbreviations are given in Part 0, Chapter 1.

CHAPTER 4

GENERAL REQUIREMENTS

The technical requirements in this chapter apply for all operating modes and product configurations.

EUT shall comprise the Inland ECDIS software, the processing unit, the monitor and peripheral equipment (keyboard, mouse, etc.) as a minimum setup.

Article 4.01

Ordering principles of the clauses

Depending on the technical equipment, Inland ECDIS can be used on board a vessel in two different operation modes:

1. Inland ECDIS in "**navigation mode**"

This means the use of the Inland ECDIS for conning the vessel with overlaid radar image. The fall-back mode for navigation mode is information mode.

The main precondition for this operation mode is the connection between type approved navigational radar and Inland ECDIS.

2. Inland ECDIS in "**Information mode**"

This is the operation mode for Inland ECDIS, when no connection between radar and Inland ECDIS is established.

3. The term "**all modes**" is used for requirements, which have to be fulfilled in both operation modes of Inland ECDIS, in "navigation mode" as well as in "information mode".

As the Inland ECDIS Part itself orders all operational and performance requirements (general requirements and specifications) by the operational modes of Inland ECDIS, this Test Part of Inland ECDIS maintains this principle.

The clauses are composed of three parts:

- a) Reference
Points to the related specification in the Inland ECDIS Part.
- b) Test method
Describes the individual preconditions and the used procedure of this clause.
- c) Required test result
Defines the target state after the performed test, which is necessary to pass the test.

Article 4.02
General preconditions and test equipment

As well as the specific preconditions, which are described in each clause, this section defines some general preconditions. In addition, data sets and tools are defined to provide a common basis for testing.

1. Special charts for testing

A list of special IENCs, needed to fulfil the clauses of this Part, can be found in Chapter 8, Article 8.01 of this Part.

2. Special tools for testing

Special test equipment is needed to fulfil the clauses of this Part. A description can be found in Chapter 8 of this Part.

3. Preconditions for performing laboratory tests in accordance with the clauses of Inland ECDIS in “all operation modes” and “information mode”.

Unless otherwise stated the Inland ECDIS in information mode or in navigation mode shall be set to the standard operation setup which is understood to be as follows:

- a) Inland ECDIS shall be connected to an AIS protocol simulator as described in Chapter 8, Article 8.02 of this Part.
- b) Inland ECDIS shall be connected to a GNSS protocol simulator as described in Chapter 8, Article 8.03 of this Part.
- c) All control elements such as keyboard, mouse, etc. shall be connected to Inland ECDIS hardware.
- d) The Inland ECDIS monitor shall be connected to the Inland ECDIS computer.
- e) The Inland ECDIS shall be set to information mode.
- f) Inland ECDIS shall be connected to a heading protocol simulator as described in Chapter 8, Article 8.05 of this Part.

4. Preconditions for clauses of Inland ECDIS in “navigation mode” completed in a laboratory

Unless otherwise stated the Inland ECDIS in navigation mode shall be set to the standard operation setup which is understood to be as follows:

- a) A recorded real-life scenario (“scenario 01”) shall be played back and fed into the Inland ECDIS.
- b) All control elements such as keyboard, mouse, etc. shall be connected to the Inland ECDIS hardware.
- c) The Inland ECDIS monitor shall be connected to the Inland ECDIS computer.
- d) The radar overlay shall be activated so that Inland ECDIS is in navigation mode.

5. Preconditions for clauses of Inland ECDIS in “navigation mode” completed aboard a vessel

Unless otherwise stated the Inland ECDIS in navigation mode shall be set to the standard operation setup which is understood to be as follows:

- a) Inland ECDIS shall be connected to the AIS protocol manipulator as described in Chapter 8, Article 8.07 of this Part. The AIS protocol manipulator shall be connected to a type-approved, fully operable Inland AIS device, installed on the same vessel.
- b) Inland ECDIS shall be connected to the GNSS protocol manipulator as described in Chapter 8, Article 8.08 of this Part. The GNSS protocol manipulator shall be connected to a type-approved, fully operable GNSS receiver, installed on the same vessel. This receiver can be the THD, if it is approved for this purpose.
- c) Inland ECDIS shall be connected to a type-approved, fully operable navigational radar installation, installed on the same vessel.
- d) Inland ECDIS shall be connected to a type-approved, fully operable rate of turn indicator device, installed on the same vessel.
- e) Inland ECDIS shall be connected to the heading protocol manipulator as described in Chapter 8, Article 8.09 of this Part. The heading protocol manipulator shall be connected to a type-approved, fully operable Transmitting Heading Device (THD, i.e. GPS compass), installed on the same vessel.
- f) All control elements such as keyboard, mouse, etc. shall be connected to the Inland ECDIS hardware.
- g) The Inland ECDIS monitor shall be connected to the Inland ECDIS computer.
- h) The radar overlay shall be activated so that Inland ECDIS is in navigation mode.

CHAPTER 5
OPERATIONAL AND PERFORMANCE REQUIREMENTS, METHODS OF TEST
AND REQUIRED TEST RESULTS
COMMON TO ALL MODES OF INLAND ECDIS

Article 5.01
Content of IENC

1. Reference

This clause refers to Part I, Chapter 2, Article 2.01(1).

2. Test method

- a) The test shall be performed in a laboratory.
- b) The Inland ECDIS is set to the standard operation setup as defined in Article 4.02(3) of this Part.
- c) An IENC that comprises all minimum required features ("chart 01") shall be loaded into the Inland ECDIS.
- d) The AIS protocol simulator shall be configured in such a way that the vessel's own position is shown in the centre part of the IENC.
- e) All available features are tested with respect to the required test results by visual inspection.
- f) The results obtained shall be compared to the required test results in paragraph 3 in order to prove compliance with the requirement.

3. Required test result

The following features shall be included in the IENC and displayed by Inland ECDIS

- a) bank of waterway (at mean water level);
- b) construction (e.g. groin, longitudinal control dam, training wall – any facility that is considered as a hazard to navigation);
- c) contours of locks and dams;
- d) boundaries of the fairway/navigation channel;
- e) isolated dangers in the fairway/navigation channel under water;
- f) isolated dangers in the fairway/navigation channel above water level, such as bridges, overhead cables etc.;
- g) official Sign and Marking information (AtoN "aids-to-navigation") including the MMSI for physical AtoNs that are equipped with AIS (e.g. buoys, beacons, lights, notice marks);
- h) waterway axis with kilometric indication;
- i) location of ports and transshipment sites;
- j) reference data for water level gauges relevant to navigation;
- k) links to the external xml-files with operation times of restricting structures, in particular locks and bridges.

Article 5.02
Updates

1. Reference

This clause refers to Part I, Chapter 2, Article 2.02(1).

2. Test method

- a) The test shall be performed in a laboratory.
- b) The Inland ECDIS is set to the standard operation setup as defined in Article 4.02(3) of this Part.
- c) A set of IENCs that comprise more than one IENC cell ("chart 02") shall be loaded into the Inland ECDIS.
- d) The AIS protocol simulator shall be configured in such a way that the vessel's own position is shown in the centre of the screen; at least two IENC cells shall be displayed.
- e) The update process shall be initialised with a specific incremental update, referring to one of the loaded IENC cells ("inc_update_file_02-01").
- f) The results obtained shall be compared to the required test results in paragraph 3(a) in order to prove compliance with the requirement.
- g) An incremental update with one incremental update file, with no reference to any of the loaded IENC cells ("inc_update_file_02-02"), shall then be applied.
- h) The results obtained shall be compared to the required test results in paragraph 3(b) in order to prove compliance with the requirement.
- i) An additional incremental update with more than one incremental update file, referring to the same loaded IENC cells ("inc_update_file_02-03"), shall then be applied.
- j) The results obtained shall be compared to the required test results in paragraph 3(c) in order to prove compliance with the requirement.
- k) Finally, the file with the record of the edition, updates and overlay cells shall be opened for inspection.
- l) The results obtained shall be compared to the required test results in paragraph 3(d) in order to prove compliance with the requirement.

3. Required test result

- a) The incremental update, referring to (based on) one of the loaded IENC cells, shall be applied automatically. The implementation procedure of the update shall not interfere with the display in use.
- b) The incremental update, not referring to any of the loaded IENC cells shall be refused and the Inland ECDIS shall indicate an appropriate error message.
- c) All incremental update instructions shall be applied correctly and shall be executed in the right order.
- d) The opened file shall include the record of all information regarding edition, updates and overlay cells of all loaded cells, including the time of application.

Article 5.03
Screen orientation, chart orientation, positioning and shifting

1. Reference

This clause refers to Part I, Chapter 2, Article 2.03(2).

2. Test method

- a) The test shall be performed in a laboratory.
- b) The Inland ECDIS is set to the standard operation setup as defined in Article 4.02(3) of this Part.
- c) An IENC ("chart 01") shall be loaded into the Inland ECDIS. The display of the boatmaster's own vessel's position shall be switched on.
- d) The AIS protocol simulator shall be configured in such a way that the vessel's own position is shown in the centre of the screen.
- e) The results obtained shall be compared to the required test results in paragraph 3 in order to prove compliance with the requirement.
- f) The position source shall be switched to an external Electronic Position Fixing Device (EPFD), e.g. a GPS receiver.
- g) The AIS protocol simulator shall be switched off.
- h) The GNSS protocol simulator shall be configured in such a way that the vessel's own position is shown in the centre of the screen, slightly offset from the previous AIS position.
- i) The results obtained shall be compared to the required test results in paragraph 3 in order to prove compliance with the requirement.
- j) The AIS protocol and the GNSS protocol simulator shall be switched on.
- k) The results obtained shall be compared to the required test results in paragraph 3 in order to prove compliance with the requirement.

3. Required test result

The boatmaster's own vessel's position shall be represented correctly by an appropriate symbol on the screen when connected to an Inland AIS device, an EPFD, or both.

Article 5.04
Display of SENC information

1. Reference

This clause refers to Part I, Chapter 2, Article 2.03(4).

2. Test method

- a) The test shall be performed in a laboratory.
- b) The Inland ECDIS is set to the standard operation setup as defined in Article 4.02(3) of this Part.
- c) Inland ECDIS shall be set to factory default settings.
- d) An appropriate IENC with depth information and water level model ("chart 03") shall be loaded into the Inland ECDIS and a time variable depth information shall be applied to the IENC. The current water level shall be applied.

- e) The AIS protocol simulator shall be configured in such a way that the vessel's own position is shown in the centre part of the IENC.
 - f) The display mode in which Inland ECDIS starts shall be compared to the required test results in paragraph 3(a) in order to prove compliance with the requirement.
 - g) The display modes "Display Base", "Standard Display" and "All Display" shall be activated consecutively. In each mode, the indication of information density and time variable depth information shall be compared to the required test results in paragraph 3(b) in order to prove compliance with the requirement.
 - h) It shall be switched from any display mode to Standard Information Mode.
 - i) The results obtained shall be compared to the required test results in paragraph 3(c) in order to prove compliance with the requirement.
 - j) Within a sample, at least five features of any display category shall be selected arbitrarily and checked whether their feature classes are in accordance with the definitions in the look-up tables.
 - k) The results obtained shall be compared to the required test results in paragraph 3(d) in order to prove compliance with the requirement.
 - l) A demanded safety depth limit shall be selected. The chart shall be inspected regarding the displayed of depth areas and safety depth limits.
 - m) The results obtained shall be compared to the required test results in paragraph 3(e) in order to prove compliance with the requirement.
 - n) The safety depth limit shall be set to a value higher than the actual water depth. The indication of Inland ECDIS shall be compared to the required test results in paragraph 3(f) in order to prove compliance with the requirement.
3. Required test result
- a) When starting the Inland ECDIS the first time (factory default), display mode "Standard Display (Standard Information Density)" shall first come up.
 - b) At least display modes "Display Base", "Standard Display" and "All Display" shall be implemented. Inland ECDIS shall clearly indicate the information density in use at all times and the time variable depth information in the IENC shall be displayed regardless of the three display modes.
 - c) It shall be possible to switch to any display mode and it shall be possible to switch to display mode "Standard Information Density" at any time by a single user action.
 - d) The feature classes of the selected features shall be in accordance with the definitions in the look-up-tables.
 - e) It shall be possible to select safety depth limits. The corresponding depth areas shall be displayed according to the selected safety depth limit.
 - f) If the water depth is below the safety depth limits, Inland ECDIS shall indicate this by an appropriate warning.

Article 5.05
Colours and symbols

1. Reference

This clause refers to Part I, Chapter 2, Article 2.03(5).

2. Test method

- a) The test shall be performed in a laboratory.
- b) The Inland ECDIS shall be set to the standard operation setup as defined in Article 4.02(3) of this Part.
- c) A test IENC ("chart 00"), comprising all symbols from the Inland ECDIS symbol library and a selection of representative line and area features, shall be loaded into the Inland ECDIS.
- d) The AIS protocol simulator shall be configured in such a way that the vessel's own position is shown in the centre part of the IENC.
- e) The displayed symbols shall be checked for completeness and correctness against the Inland ECDIS symbol library.
- f) The results obtained shall be compared to the required test results in paragraph 3(a) in order to prove compliance with the requirement.
- g) Check whether it is possible to set the Inland ECDIS to colour combinations day, dusk and night.
- h) The results obtained shall be compared to the required test results in paragraph 3(b) in order to prove compliance with the requirement.
- i) An IENC ("chart 04"), comprising all additional symbols provided by the manufacturer, shall be loaded into the Inland ECDIS. The Inland ECDIS, with the specific presentation library of the manufacturer, shall be compared to the Inland ECDIS symbol library as defined in Annex 2.
- j) The results obtained shall be compared to the required test results in paragraph 3(c) in order to prove compliance with the requirement.

3. Required test result

- a) The displayed symbols shall be correct and complete compared to the Inland ECDIS symbol library as defined in Annex 2. The colours of the representative line and area features, as well as the symbols, shall also be correct. The symbols that deviate from the Inland ECDIS presentation library shall:
 - i) be legible,
 - ii) have sufficient size to support the nominal viewing distance.
- b) At least the colour combinations of day, dusk and night shall be supported.
- c) The added symbols to the presentation library by the manufacturer shall be clearly distinguishable from the default Inland ECDIS symbols (as defined in Annex 2).

Article 5.06
Scale dependent information density (SCAMIN)

1. Reference

This clause refers to Part I, Chapter 2, Article 2.03(6).

2. Test method

- a) The test shall be performed in a laboratory.
- b) The Inland ECDIS shall be set to the standard operation setup as defined in Article 4.02(3) of this Part.
- c) An IENC ("chart 05"), comprising a bridge across a waterway, shall be loaded into the Inland ECDIS.
- d) The AIS protocol simulator shall be configured in such a way that the vessel's own position is shown in the centre part of the IENC.
- e) Inland ECDIS is set to minimum scale and switched until maximum scale, step-by-step consecutively. In each scale, the display of the symbols at the bridge shall be inspected with respect to the SCAMIN values.
- f) The results obtained shall be compared to the required test results in paragraph 3 in order to prove compliance with the requirement.

3. Required test result

The symbols related to the bridge shall be displayed according to their SCAMIN values.

Article 5.07
Features displayed in several cells with the same use for the same area

1. Reference

This clause refers to Part I, Chapter 2, Article 2.03(7).

2. Test method

- a) The test shall be performed in a laboratory.
- b) The Inland ECDIS shall be set to the standard operation setup as defined in Article 4.02(3) of this Part.
- c) Two adjacent IENCs ("chart 05a and 05b"), that both comprise parts of the same feature (e.g. a bridge, that is displayed half in the cell of one IENC and half in the cell of the other IENC) shall be loaded into the Inland ECDIS. That feature shall be correctly encoded. Both parts shall have references to each other.
- d) The AIS protocol simulator shall be configured in such a way that the vessel's own position is shown in the centre part of the IENC.
- e) This test shall include the appropriate overlay cells, e.g. with bridge-related notice marks. The display of the feature shall be compared to the required test results in paragraph 3(a) in order to prove compliance with the requirement.

3. Two adjacent IENCs that are used to define the basic cells for two additional overlay-cells, that comprise part of the same bathymetric IENC feature, shall be loaded into the Inland ECDIS. These features shall be correctly encoded (depth areas) and the separated parts shall have references to each other. The presentation of the feature shall be compared to the required test results in paragraph 3(b) in order to prove compliance with the requirement.
4. Required test result
 - a) The feature that is partly in both IENCs shall be visible and correctly displayed as one feature in the SENC.
 - b) The feature that is partly in both overlay cells shall be visible and correctly displayed as one feature in the SENC.

Article 5.08 **Display of tracking and tracing information**

1. Reference

This clause refers to Part I, Chapter 2, Article 2.03(9).
2. Test method
 - a) The test shall be performed in a laboratory.
 - b) The Inland ECDIS shall be set to the standard operation setup as defined in Article 4.02(3) of this Part.
 - c) An IENC ("chart 07") shall be loaded into the Inland ECDIS.
 - d) The results obtained shall be compared to the required test results in paragraph 3(a) in order to prove compliance with the requirement.
3. Required test result
 - a) The symbols for AIS base stations, AIS Sign and Marking information (AtoN), Application Specific Messages and AIS Search and Rescue Transmitters (SART) shall be distinguished from other symbols (e.g. symbols 2.10 and 2.11 of table A.1 and table A.2 in REF#IEC-62288).

Article 5.09 **Display of AIS targets of other vessels**

1. Reference

This clause refers to Part I, Chapter 2, Article 2.03(14).
2. Test method
 - a) The test shall be performed in a laboratory.
 - b) The Inland ECDIS shall be set to the standard operation setup as defined in Article 4.02(3) of this Part.
 - c) An IENC ("chart 07") shall be loaded into the Inland ECDIS.
 - d) The AIS protocol simulator shall be configured as an Inland AIS device and in such a way that the vessel's own position is shown in the centre part of the IENC.
 - e) The behaviour of the vessel in the chart shall be observed.

- f) The simulated vessel shall stop reporting.
- g) The time until the vessel is marked as outdated shall be measured.
- h) The time until the vessel disappears shall be measured.
- i) The results obtained shall be compared to the required test results in paragraph 3(a) in order to prove compliance with the requirement.
- j) This test shall be repeated with a simulated Inland AIS device on a vessel at anchor, not moving at more than 3 knots.
- k) The results obtained shall be compared to the required test results in paragraph 3(a) in order to prove compliance with the requirement.
- l) This test shall be repeated with a simulated Inland AIS device on a vessel at anchor, moving at more than 3 knots.
- m) The results obtained shall be compared to the required test results in paragraph 3(a) in order to prove compliance with the requirement.
- n) This test shall be repeated with a simulated AIS class B device on a vessel under way using engine.
- o) The results obtained shall be compared to the required test results in paragraph 3(a) in order to prove compliance with the requirement.
- p) This test shall be repeated with a simulated AIS class B device on a vessel at anchor, not moving at more than 3 knots.
- q) The results obtained shall be compared to the required test results in paragraph 3(a) in order to prove compliance with the requirement.
- r) This test shall be repeated with a simulated AIS class B device on a vessel at anchor, moving at more than 3 knots.
- s) The results obtained shall be compared to the required test results in paragraph 3(a) in order to prove compliance with the requirement.
- t) An appropriate AIS message with position A shall be created for the own vessel and fed into the Inland ECDIS. The position of the own vessel shall be marked in the chart.
- u) The position for this message shall be altered significantly (Position B) and the repeater flag shall be set. The occurrence of the vessel's own symbol shall be compared, for position B, to the required test results in paragraph 3(b) in order to prove compliance with the requirement.
- v) The repeater flag shall be unset.
- w) The occurrence of the vessel's own symbol shall be compared to the required test results in paragraph 3(b) in order to prove compliance with the requirement.
- x) An Inland AIS target shall be simulated with no heading information available. The presentation of this vessel shall be observed in the Inland ECDIS.
- y) The result obtained shall be compared to the required test results in paragraph 3(c). The result obtained shall be noted in the test report.
- z) Another Inland AIS target shall be simulated with heading information available. The presentation of this vessel shall be observed in the Inland ECDIS.
- aa) The result obtained shall be compared to the required test results in paragraph 3(d). The result obtained shall be noted in the test report.
- bb) The result obtained shall be compared to the required test results in paragraph 3(d) in order to prove compliance with the requirement.

- cc) A simulated vessel with all AIS information shall be fed into the Inland ECDIS. All AIS information shall be requested and displayed. A check that all data are available shall be made.
- dd) The result obtained shall be compared to the required test results in paragraph 3(d) in order to prove compliance with the requirement.
- ee) An Inland AIS target shall be simulated with three blue cones. The presentation of this vessel shall be observed in the Inland ECDIS. A pick report shall be opened for this vessel. The pick report shall be inspected regarding the number of blue cones.
- ff) The result obtained shall be compared to the required test results in paragraph 3(e) in order to prove compliance with the requirement.

3. Required test result

- a) The overlay of information gathered by communication links regarding the position and orientation of other vessels, such as AIS, shall only be allowed when:
 - i) the information is up to date (real-time), and
 - ii) the age of information does not exceed the following maximum time out values:

Category of vessel	Nominal reporting interval	Maximum time out value	Nominal reporting interval	Maximum time out value
	class A	class A	class B	class B
Vessel at anchor or moored and not moving faster than 3 knots (class B not moving faster than 2 knots)	3 min	18 min	3 min	18 min
Vessel at anchor or moored and moving at more than 3 knots	10 s	60 s	3 min	18 min
Vessel operating in SOLAS mode, moving 0 to 14 knots	10 s	60 s	30 s	180 s
Vessel operating in SOLAS mode, moving 0 to 14 knots and changing course	3 1/3 s	60 s	30 s	180 s
Vessel operating in SOLAS mode, moving 14 to 23 knots	6 s	36 s	30 s	180 s
Vessel operating in SOLAS mode, moving 14 to 23 knots and changing course	2 s	36 s	30 s	180 s
Vessel operating in SOLAS mode, moving faster than 23 knots	2 s	30 s	30 s	180 s
Vessel operating in SOLAS mode, moving faster than 23 knots and changing course	2 s	30 s	30 s	180 s
Vessel operating in inland waterway mode	2 – 10 s	60 s	—	—

- iii) The symbols shall be marked as outdated if the age of the information exceeds 30 seconds for moving vessels.
- b) The position information of the own vessel shall only be displayed when the position is detected by an on-board system and not if the position is received from a repeater station.
- c) Only if the heading of other vessels is available, the position and the orientation of those other vessels may be presented by:
 - i) a directed triangle, or
 - ii) a true outline (to scale).
- d) It shall be possible to display all information transmitted by an AIS on user request:
 - i) AIS device identity (MMSI);
 - ii) vessel name;
 - iii) VHF radio call sign of the vessel;
 - iv) vessel or convoy type;
 - v) unique European vessel Identification Number (ENI) or, for seagoing vessels that have not been given an ENI number, the IMO number;
 - vi) overall length of the vessel or convoy accurate to 0,1 m;
 - vii) overall breadth of the vessel or convoy accurate to 0,1 m;
 - viii) reference point for the positional information aboard the vessel, accurate to 1 m (this is the position of the GPS antenna of the Inland AIS device);
 - ix) position of the vessel (derived from GPS in WGS 84 coordinate system);
 - x) time indication of position determination by the electronic position location device;
 - xi) speed over ground;
 - xii) course over ground;
 - xiii) navigational status.
- e) The number of the blue cones/lights shall only be displayed in the pick report.

Article 5.10
Display of AIS Aids to Navigation

1. Reference

This clause refers to Part I, Chapter 2, Article 2.03(15).

2. Test method

- a) The test shall be performed in a laboratory.
- b) The Inland ECDIS shall be set to the standard operation mode as defined in Article 4.02(3) of this Part.
- c) The Inland AIS AtoN protocol simulator shall be connected to the Inland ECDIS.

- d) The Inland AIS AtoN protocol simulator shall be configured with the following basic setup:
- | | | |
|--------------------|---|--------|
| Message ID | = | 21 |
| AtoN type | = | 0 |
| Repeat Indicator | = | 0 |
| Position accuracy | = | 1 |
| EPFD | = | 1 |
| time stamp | = | 2 |
| RAIM flag | = | 0 |
| Assigned mode flag | = | 0 |
| extended name | = | <null> |
- e) Test of each inland AIS AtoN symbol
- The inland AIS AtoN simulator shall be set to the following values for steps (f), (g) and (h) below:
- | | | |
|-----------|---|--|
| ID | = | <any valid number> |
| longitude | = | <long> of center as provided with chart 10 |
| latitude | = | <lat> of center as provided with chart 10 |
- f) For each AtoN with Inland AtoN code 1 to 15 in Table II-9 of ES-RIS part II, the inland AIS AtoN simulator shall generate the following three PI-sentences:
- i)
- | | | |
|------------------------|---|---|
| AtoN name | = | <default, not available> |
| dist A | = | 1 |
| dist B | = | 1 |
| dist C | = | 1 |
| dist D | = | 1 |
| off Position indicator | = | 0 |
| AtoN Status | = | 00100111 (page ID for Inland AtoN =001) + Inland AtoN type (table II-9) |
| Virtual flag | = | 0 |
- ii)
- | | | |
|------------------------|---|---|
| AtoN name | = | <default, not available> |
| dist A | = | 1 |
| dist B | = | 1 |
| dist C | = | 1 |
| dist D | = | 1 |
| off Position indicator | = | 1 |
| AtoN Status | = | 00100111 (page ID for Inland AtoN =001) + Inland AtoN type (table II-9) |
| Virtual flag | = | 0 |

iii)

AtoN name = <default, not available>
 dist A = 0
 dist B = 0
 dist C = 0
 dist D = 0
 off Position indicator = 0
 AtoN Status = 00100111 (page ID for Inland AtoN =001) + Inland AtoN
 type (table II-9)
 Virtual flag = 1

g) For each AtoN with Inland AtoN code 16 to 18 in Table II-9 of ES-RIS part II, the inland AIS AtoN simulator shall generate the following PI-sentence:

AtoN name = %%90
 dist A = 0
 dist B = 0
 dist C = 0
 dist D = 0
 off Position indicator = 0
 AtoN Status = 00100111 (page ID for Inland AtoN =001) + Inland AtoN
 type (table II-9)
 Virtual flag = 1

h) For AtoN with Inland AtoN code 19 in Table II-9 of ES-RIS part II, the inland AIS AtoN simulator shall generate the following two PI-sentences:

i)

AtoN name = <default, not available>
 dist A = 1
 dist B = 1
 dist C = 1
 dist D = 1
 off Position indicator = 0
 AtoN Status = 00100111 (page ID for Inland AtoN =001) + Inland AtoN
 type (table II-9)
 Virtual flag = 0

ii)

AtoN name = <default, not available>
 dist A = 1
 dist B = 1
 dist C = 1
 dist D = 1
 off Position indicator = 1
 AtoN Status = 00100111 (page ID for Inland AtoN =001) + Inland AtoN
 type (table II-9)
 Virtual flag = 0

i) The presentation of each AtoN generated in steps (f), (g) and (h) shall be compared to the required test results in paragraph 3(a) in order to prove compliance with the requirement.

j) The size of the inland AIS AtoN symbols and text shall be measured with a ruler and compared to the required test results in paragraph 3(b) in order to prove compliance with the requirement.

k) An appropriate IENC ("chart 09") shall be loaded into the Inland ECDIS with
i) one AtoN object with a MMSI number (AtoN name : "OBJ_NAME_1") and
ii) one AtoN object without a MMSI number (AtoN name: "OBJ_NAME_2")

The AtoN type of OBJ1 ("OBJ_TYPE_1") and OBJ2 ("OBJ_TYPE2") and their AIS counterpart ("OBJ_TYPE_AIS_1" and "OBJ_TYPE_AIS_2") shall be identified according to the Annex 2, presentation library for IENCs.

The display of OBJ1 and OBJ2 shall be compared to the required test results in paragraph 3(i) in order to prove compliance with the requirement.

l) Inland AIS AtoN with match – on position

The inland AIS AtoN simulator as specified in Article 8.09 shall generate an inland AIS AtoN message with the following content:

```
ID                = MMSI of OBJ1
AtoN name         = OBJ1
longitude         = <long> of OBJ1 + x1
latitude         = <lat> of OBJ1 + y1
dist A           = 1
dist B           = 1
dist C           = 1
dist D           = 1
off Position Indicator = 0
AtoN Status      = 00100111 (page ID for Inland AtoN 001) + Inland AtoN
type (table II-9) of OBJ1
Virtual flag     = 0
```

x1 and y1 shall be chosen such that the inland AIS AtoN is close to the original position and still displayed in the chart 09.

The representation of the inland AIS AtoN in relation to the matched IENC object shall be compared to the required test results in paragraph 3(d) in order to prove compliance with the requirement.

m) Inland AIS AtoN with match – off position

The inland AIS AtoN simulator as specified in Article 8.09 shall generate an inland AIS AtoN message with the following content:

```
ID                = MMSI of OBJ1
AtoN name         = OBJ1
longitude         = <long> of OBJ1 + x2
latitude         = <lat> of OBJ1 + y2
dist A           = 1
dist B           = 1
dist C           = 1
dist D           = 1
off Position Indicator = 1
AtoN Status      = 00100111 (page ID for Inland AtoN =001) + Inland AtoN
type (table II-9) of OBJ1
Virtual flag     = 0
```

x2 and y2 shall be chosen such that the position of inland AIS AtoN is significantly offset but is still displayed in the chart 09.

The representation of the inland AIS AtoN shall be compared to the required test results in paragraph 3(i) in order to prove compliance with the requirement.

n) Inland AIS AtoN without match – on position

The Inland AIS AtoN simulator as specified in Article 8.09 shall generate an inland AIS AtoN message with the following content:

```
ID                = <any valid number>
AtoN name        = OBJ2
longitude        = <long> of OBJ2 + x1
latitude        = <lat> of OBJ2 + y1
dist A          = 1
dist B          = 1
dist C          = 1
dist D          = 1
off Position Indicator = 0
AtoN Status     = 00100111 (page ID for Inland AtoN =001) + Inland AtoN
type (table II-9) of OBJ2
Virtual flag    = 0
```

x1 and y1 shall be chosen such that the inland AIS AtoN is close to the original position and still displayed in the chart 09.

The representation of the inland AIS AtoN shall be compared to the required test results in paragraph 3(f) for different scales of the display in order to prove compliance with the requirement.

o) Inland AIS AtoN without match – off position

The inland AIS AtoN simulator as specified in Article 8.09 shall generate an inland AIS AtoN message with the following content:

```
ID                = <any valid number>
AtoN name        = OBJ2
longitude        = <long> of OBJ2 + x2
latitude        = <lat> of OBJ2 + y2
dist A          = 1
dist B          = 1
dist C          = 1
dist D          = 1
off Position Indicator = 1
AtoN Status     = 00100111 (page ID for Inland AtoN =001) + Inland AtoN
type (table II-9) of OBJ2
Virtual flag    = 0
```

x2 and y2 shall be chosen such that the position of inland AIS AtoN is significantly offset but is still displayed in the chart 09.

The representation of the inland AIS AtoN shall be compared to the required test results in paragraph 3(g) in order to prove compliance with the requirement.

p) Virtual inland AIS AtoN without a direction of impact

The inland AIS AtoN simulator as specified in Article 8.09 shall generate an inland AIS AtoN message without a direction of impact with the following content:

```

ID                = <any valid number>
AtoN name         = OBJ_VIRT
longitude         = <long> - center of chart 09
latitude         = <lat> - center of chart 09
dist A           = 0
dist B           = 0
dist C           = 0
dist D           = 0
off Position Indicator = 0
AtoN Status      = 00100111 (page ID for Inland AtoN =001) + Inland AtoN
type (table II-9)
Virtual flag     = 1

```

The Inland AtoN type shall be of any of Inland AtoN codes 1 to 15 according to table II-9.

The representation of the inland AIS AtoN shall be compared to the required test results in paragraph 3(h) in order to prove compliance with the requirement.

q) Virtual inland AIS AtoN with a direction of impact

The inland AIS AtoN simulator as specified in Article 8.09 shall generate an inland AIS AtoN message with a direction of impact with the following content:

```

ID                = <any valid number>
AtoN name         = OBJ_VIRT%%<arbitrary value>(the arbitrary value shall
be in the range from 1 to 359 with the exemption of 180)
longitude         = <long> - center of chart 09
latitude         = <lat> - center of chart 09
dist A           = 0
dist B           = 0
dist C           = 0
dist D           = 0
off Position Indicator = 0
AtoN Status      = 00100111 (page ID for Inland AtoN =001) + Inland AtoN
type (table II-9)
Virtual flag     = 1

```

The Inland AtoN type shall be of any of Inland AtoN codes 16 to 18 according to table II-9.

Note: 0°, 180°, 360° shall not be used for the direction of impact since the correct clockwise rotation can't be checked with these values.

The representation of the inland AIS AtoN shall be compared to the required test results in paragraph 3(i) in order to prove compliance with the requirement.

r) Time out

Start an alarm timer set to 18 min and wait until the alarm timer gives an alarm.

The presentation of the chart shall be compared to the required test results in paragraph 3(j) in order to prove compliance with the requirement.

3. Required test result
- a) Test of all inland AIS AtoN symbols
It shall be checked if each AtoN symbol is displayed in accordance with table 5.1.2 of Annex 2 (presentation library).
 - b) Size of symbols and text
The minimum size of AIS symbols and the minimum text height of AIS information shall be 3,5 mm.
 - c) OBJ1 and OBJ2 shall be displayed according to Annex 2 in the chart.
 - d) Inland AIS AtoN with match – on position
The inland AIS AtoN symbol shall be displayed in the chart at the position as specified in the inland AIS AtoN PI sentence. The corresponding IENC object shall not be displayed any more.
 - e) Inland AIS AtoN with match – off position
The appropriate inland AIS AtoN symbol with the letter “m” shall be displayed on the position of the IENC object and the appropriate inland AIS AtoN symbol with the letter “o” shall be displayed at the position as specified in the inland AIS AtoN PI sentence.
 - f) Inland AIS AtoN without match – on position
The inland AIS AtoN symbol shall be displayed in the chart at the position as specified in the inland AIS AtoN PI sentence. The IENC object shall also be displayed.
Depending on the scale for the display of the map, the symbols shall either be displayed completely separated or overlapped, with the IENC symbol behind the inland AIS AtoN symbol.
 - g) Inland AIS AtoN without match – off position
The appropriate inland AIS AtoN symbol with the letter “o” shall be displayed at the position as specified in the inland AIS AtoN PI sentence. The IENC object shall also be displayed.
 - h) Virtual inland AIS AtoN without a direction of impact
The appropriate inland AIS AtoN symbol with a dotted diamond shall be displayed at the position as specified in the inland AIS AtoN PI sentence.
 - i) Virtual inland AIS AtoN with a direction of impact
The appropriate inland AIS AtoN symbol shall be displayed at the position as specified in the inland AIS AtoN PI sentence. The direction of impact shall be indicated in the clockwise direction from the north direction.
Note: These inland AIS AtoN have no dotted diamond, although they are virtual.
 - j) Time out
All inland AIS AtoN symbols shall have disappeared. Only the IENC object for OBJ1 and OBJ2 are shown.

Article 5.11 **Operation**

1. Reference

This clause refers to Part I, Chapter 2, Article 2.04(1).

2. Test method
 - a) The test shall be performed in a laboratory.
 - b) The Inland ECDIS shall be set to the standard operation setup as defined in Article 4.02(3) of this Part.
 - c) An IENC (“chart 07”) shall be loaded into the Inland ECDIS.
 - d) The AIS protocol simulator shall be configured in such a way that the vessel’s own position is shown in the centre part of the IENC.
 - e) A vessel shall be simulated with heading information available. The data of that vessel are fed into the Inland ECDIS.
 - f) The presentation of that vessel in the Inland ECDIS is compared to the required test results in paragraph 3(a) in order to prove compliance with the requirement.
 - g) An additional vessel shall be simulated with no heading information available. The data of that vessel are fed into the Inland ECDIS.
 - h) The presentation of that vessel in the Inland ECDIS is compared to the required test results paragraph 3(b) in order to prove compliance with the requirement.
3. Required test result
 - a) A vessel with heading available shall be presented correctly with respect to position and orientation with a true outline (to scale) or a directed triangle.
 - b) A vessel without heading shall be presented correctly with respect to position with a generic symbol (an octagon or a circle).

Article 5.12 ***Ergonomics of control elements***

1. Reference

This clause refers to Part I, Chapter 2, Article 2.04(2).
2. Test method
 - a) The test shall be performed in a laboratory.
 - b) The Inland ECDIS shall be set to the standard operation setup as defined in Article 4.02(3) of this Part.
 - c) A recorded real-life scenario (“scenario 01”) shall be played back and fed into the Inland ECDIS.
 - d) The manufacturer shall provide appropriate information about the applied human machine interface. This information is compared to the required test results in paragraph 3(a) in order to prove compliance with the requirement.
 - e) The Inland ECDIS shall be switched to each available mode (information mode, navigation mode). In each mode, the indication of the mode as well as the connected peripherals are observed.
 - f) The results obtained shall be compared to the required test results in paragraph 3(b) in order to prove compliance with the requirement.
 - g) The height of the characters of the control elements shall be measured with an appropriate measurement tool (e.g. a ruler).
 - h) The result obtained shall be compared to the required test results in paragraph 3(b) in order to prove compliance with the requirement.

3. Required test result
 - a) The manufacturer shall provide information as to which widely accepted human machine interface is applied.
 - b) The operational state (Inland ECDIS in information mode / Inland ECDIS in navigation mode) of the system and the connected peripherals shall be clearly indicated.
 - c) The symbols of the control elements shall have a minimum character height of 4 mm.

Article 5.13 **Characteristics of control elements**

1. Reference

This clause refers to Part I, Chapter 2, Article 2.04(3).

2. Test method

- a) The test shall be performed in a laboratory.
- b) The Inland ECDIS shall be set to the standard operation setup as defined in Article 4.02(3) of this Part.
- c) A recorded real-life scenario ("scenario 01") shall be played back and fed into the Inland ECDIS.
- d) The control elements shall be operated and checked against ergonomics and functionality.
- e) The result obtained shall be compared to the required test results in paragraph 3(a) in order to prove compliance with the requirement.
- f) The manufacturer shall provide a document that comprises a statement indicating which additional national language versions are supported.
- g) The result obtained shall be compared to the required test results in paragraph 3(b) in order to prove compliance with the requirement.

3. Required test result

- a) All control elements shall fulfil the requirements regarding the ergonomic and functional modes of operation.
- b) The statement of the manufacturer shall be noted in the test report. No verification of other language versions shall be performed.

Article 5.14 **Pick report**

1. Reference

This clause refers to Part I, Chapter 2, Article 2.04(4).

2. Test method

- a) The test shall be performed in a laboratory.
- b) The Inland ECDIS shall be set to the standard operation setup as defined in Article 4.02(3) of this Part.
- c) An IENC ("chart 08") shall be loaded into the Inland ECDIS.

- d) The AIS protocol simulator shall be configured in such a way that the vessel's own position is shown in the centre part of the IENC.
 - e) At least five different features from different feature classes of the IENC shall be selected arbitrarily. For each feature, the pick report shall be activated and the content of the pick report shall be compared to the required test results in paragraph 3(a) and (b) in order to prove compliance with the requirement.
3. Required test result
- a) All underlying textual and/or graphical information (attributes) of the selected feature shall be displayed in the pick report.
 - b) The pick report shall not hamper the view of the waterway in the navigational chart.

Article 5.15 **Measuring features**

1. Reference

This clause refers to Part I, Chapter 2, Article 2.04(5).

2. Test method

- a) The test shall be performed in a laboratory.
- b) The Inland ECDIS shall be set to the standard operation setup as defined in Article 4.02(3) of this Part.
- c) An IENC ("chart 01") shall be loaded into the Inland ECDIS.
- d) The AIS protocol simulator shall be configured in such a way that the vessel's own position is shown in the centre part of the IENC.
- e) The measurement features for distances and bearings shall be activated.
- f) The results obtained shall be compared to the required test results in paragraph 3 in order to prove compliance with the requirement.

3. Required test result

Measuring features for distances and bearings shall be implemented.

Article 5.16 **Input and editing of boatmasters' own chart entries**

1. Reference

This clause refers to Part I, Chapter 2, Article 2.04(6).

2. Test method

- a) The test shall be performed in a laboratory.
- b) The Inland ECDIS shall be set to the standard operation setup as defined in Article 4.02(3) of this Part.
- c) An IENC ("chart 07") shall be loaded into the Inland ECDIS.
- d) The AIS protocol simulator shall be configured in such a way that the vessel's own position is shown in the centre part of the IENC.

- e) A new own chart entry shall be created by placing a single point-shaped object and text, and by drawing a line and a closed polygon (area), if available.
 - f) The new created chart entry shall be stored. Another IENC ("chart 01") shall be loaded into the Inland ECDIS. The original IENC ("chart 07") with the entry shall then be reloaded.
 - g) The occurrence of the previously created entry shall be compared to the required test results in paragraph 3(a) in order to prove compliance with the requirement.
 - h) The entry shall be modified shifting it to another position. Another IENC ("chart 01") shall be loaded into the Inland ECDIS. The original IENC ("chart 07") with the entry shall then be reloaded.
 - i) The occurrence of the previously created entry shall be compared to the required test results in paragraph 3(b) in order to prove compliance with the requirement.
 - j) The previously created entry shall be deleted. Another IENC ("chart 01") shall be loaded into the Inland ECDIS. The original IENC ("chart 07") with the entry shall then be reloaded.
 - k) The occurrence of the previously created entry shall be compared to the required test results in paragraph 3(c) in order to prove compliance with the requirement.
3. Required test result
- a) It shall be possible to create and store a new entry. After reloading the chart, the created entry shall still exist.
 - b) It shall be possible to move the previously created entry to another position in the same IENC. After reloading the chart, the modified entry shall still exist.
 - c) It shall be possible to delete the previously created entry. After reloading the chart, the previously created entry shall not exist anymore.

Article 5.17 **Control elements**

1. Reference

This clause refers to Part I, Chapter 2, Article 2.04(9).

2. Test method

- a) The test shall be performed in a laboratory.
- b) The Inland ECDIS shall be set to the standard operation setup as defined in Article 4.02(3) of this Part.
- c) A recorded real-life scenario ("scenario 01") shall be played back and fed into the Inland ECDIS.
- d) The manufacturer shall provide a document that comprises a statement indicating which ergonomic principles for user-friendly operation are applied.
- e) The statement shall be compared to the required test results in paragraph 3(a) in order to prove compliance with the requirement.
- f) Each control element shall be inspected as to whether it is necessary.

- g) The result obtained shall be compared to the required test results in paragraph 3(b) in order to prove compliance with the requirement.
 - h) Each standard setting and user-defined setting shall be checked with respect to whether it is easily retrievable.
 - i) The result obtained shall be compared to the required test results in paragraph 3(c) in order to prove compliance with the requirement.
 - j) The following functions shall be activated consecutively; for each function checks shall be carried out regarding access, kind of control, menu level and visibility:
 - i) "range",
 - ii) "brightness",
 - iii) "colours",
 - iv) "information density".
 - k) The result obtained shall be compared to the required test results in paragraph 3(d) in order to prove compliance with the requirement.
 - l) The following elements shall be checked for permanent visibility:
 - i) range (actual range);
 - ii) status (sensor status: alarms and, if connected, GNSS receiver, AIS and heading device);
 - iii) water level (selected water level, if available);
 - iv) safety depth limit (selected safety depth limit, if available);
 - v) information density (selected information density).
 - m) The result obtained shall be compared to the required test results in paragraph 3(e) in order to prove compliance with the requirement.
3. Required test result
- a) The statement of the manufacturer shall comprise appropriate information to which ergonomic principles for user-friendly operation are applied.
 - b) The Inland ECDIS shall have a minimum of control elements.
 - c) All standard settings and user-defined settings shall be easy to find and recover.
 - d) The following operational functions shall have direct access and shall have either own control elements or own menu areas, which are arranged in the highest menu level and are permanently visible:
 - i) "range",
 - ii) "brightness",
 - iii) "colours",
 - iv) "information density".
 - e) The following function parameters are always visible:
 - i) range (actual range);
 - ii) status (sensor status: alarms, and if connected GNSS receiver, AIS and heading device);
 - iii) water level (selected water level, if available);
 - iv) safety depth limit (selected safety depth limit, if available);
 - v) information density (selected information density).

Article 5.18
Operation of AIS targets of other vessels

1. Reference

This clause refers to Part I, Chapter 2, Article 2.04(10).

2. Test method

- a) This test shall be conducted aboard a vessel under way, or in a laboratory.
- b) The Inland ECDIS shall be set to the standard operation setup as defined in Article 4.02(5) of this Part, if executed aboard a vessel and as defined in Article 4.02(4) of this Part if executed in a laboratory.
- c) If executed in a laboratory, the AIS protocol simulator shall be configured in such a way that the vessel's own position is shown in the centre of the screen. It shall provide information for at least two other vessels equipped with AIS to the Inland ECDIS.
- d) If executed aboard a vessel, information of at least two other vessels equipped with AIS shall be available and shall be fed into the Inland ECDIS by the Inland AIS device.
- e) AIS labels shall be switched on manually.
- f) The behaviour of the Inland ECDIS chart shall be compared to the required test results in paragraph 3(a) in order to prove compliance with the requirement.
- g) AIS labels shall be switched off manually.
- h) The behaviour of the Inland ECDIS chart shall be compared to the required test results in paragraph 3(a) in order to prove compliance with the requirement.
- i) A timeout value for AIS labels of 7 seconds shall be configured if the timeout feature of AIS is available.
- j) Inland AIS labels shall be switched on.
- k) The behaviour of the Inland ECDIS chart regarding the time until the AIS labels disappear automatically shall be compared to the required test results in paragraph 3(b) in order to prove compliance with the requirement.

3. Required test result

- a) It shall be possible to temporarily switch Inland AIS labels on and off manually.
- b) The Inland AIS labels shall disappear after the specified time when a timeout value is set.

Article 5.19
Service functions

1. Reference

This clause refers to Part I, Chapter 2, Article 2.05(1).

2. Test method

- a) The test shall be performed in a laboratory.
- b) The Inland ECDIS shall be set to the standard operation setup as defined in Article 4.02(3) of this Part.

- c) The service function menu shall be opened. The presence or not of a password protection shall be noted.
 - d) The result obtained shall be compared to the required test results in paragraph 3 in order to prove compliance with the requirement.
3. Required test result
- All service functions shall be protected by password or other suitable measures against unauthorised access.

Article 5.20 **Display**

1. Reference
- This clause refers to Part I, Chapter 2, Article 2.06(2).
2. Test method
 - a) The test shall be performed in a laboratory.
 - b) The Inland ECDIS shall be set to the standard operation setup as defined in Article 4.02(3) of this Part.
 - c) A recorded real-life scenario ("scenario 01") shall be played back and fed into the Inland ECDIS.
 - d) The screen and display shall be set to portrait format.
 - e) The nominal viewing distance shall be obtained from the manufacturer's documentation.
 - f) All alphanumeric data and texts shall be checked for:
 - i) legibility,
 - ii) font type,
 - iii) font size,
 - iv) the character height and the size of the AIS symbols in millimetres.
 - g) The result obtained shall be compared to the required test results in paragraph 3 in order to prove compliance with the requirement.
 - h) The display shall be set to landscape format. The test shall be repeated.
 - i) The result obtained shall be compared to the required test results in paragraph 3 in order to prove compliance with the requirement.
 3. Required test result
- The following requirements shall be fulfilled in both landscape and portrait formats:
- a) alphanumeric data and text shall be presented using a clearly legible non-italic sans-serif font;
 - b) the font size shall be appropriate for the viewing distance from user positions (i.e. with respect to reading distance and viewing angles) likely to be experienced in the wheelhouse of a vessel;
 - c) the minimum character height and the minimum size of AIS symbols in millimetres shall not be less than 3,5 times the typically nominal viewing distance in meters; and
 - d) the minimum size of AIS symbols and the minimum character height of AIS information shall be 3,5 mm.

Article 5.21
Display colours

1. Reference

This clause refers to Part I, Chapter 2, Article 2.06(5).

2. Test method

- a) The test shall be performed in a laboratory.
- b) The Inland ECDIS shall be set to the standard operation setup as defined in Article 4.02(3) of this Part.
- c) A recorded real-life scenario ("scenario 01") shall be played back and fed into the Inland ECDIS.
- d) The Inland ECDIS shall be set to colour combination day, dusk and night consecutively. Each colour combination shall be checked to determine whether the chart is displayed in ergonomically proven colours.
- e) The result obtained shall be compared to the required test results in paragraph 3 in order to prove compliance with the requirement.

3. Required test result

The system shall be able to display the chart in ergonomically proven colour combinations for day, dusk and night.

Article 5.22
Display and screen brightness

1. Reference

This clause refers to Part I, Chapter 2, Article 2.06(6).

2. Test method

- a) The test shall be performed in a laboratory.
- b) The Inland ECDIS shall be set to the standard operation setup as defined in Article 4.02(3) of this Part.
- c) A recorded real-life scenario ("scenario 01") shall be played back and fed into the Inland ECDIS.
- d) The test shall be conducted in a dark room.
- e) The Inland ECDIS shall be set to colour combination night-time.
- f) The brightness of the screen (hardware button on the monitor) shall be set to minimum or if the screen is completely dark, to the lowest level where the chart can be seen.
- g) The result obtained shall be compared to the required test results in paragraph 3 in order to prove compliance with the requirement.
- h) The brightness shall be increased slightly and the colour saturation shall be decreased by the software setting until the chart is just visible.
- i) The result obtained shall be compared to the required test results in paragraph 3 in order to prove compliance with the requirement.
- j) The room shall be set to normal light conditions.

- k) The Inland ECDIS shall be set to colour combination day.
- l) The brightness of the screen (hardware button on the monitor) shall be set to maximum.
- m) The result obtained shall be compared to the required test results in paragraph 3 in order to prove compliance with the requirement.
- n) The brightness shall be slightly decreased, and the colour saturation shall be increased by the software setting to its maximum value.
- o) The result obtained shall be compared to the required test results in paragraph 3 in order to prove compliance with the requirement.

3. Required test result

The brightness of the display shall be adjustable to every operational reasonable value. The lowest value shall be low enough to ensure safe operation at night-time.

Article 5.23 **Connection of other equipment**

1. Reference

This clause refers to Part I, Chapter 2, Article 2.07(1).

2. Test method

- a) The test shall be performed in a laboratory.
- b) The Inland ECDIS shall be set to the standard operation setup as defined in Article 4.02(3) of this Part.
- c) An IENC ("chart 07") shall be loaded into the Inland ECDIS.
- d) An Inland AIS protocol simulator shall be connected, providing position information for a position A.
- e) The vessel's own position shall be confirmed by observation on the chart and marked.
- f) The AIS protocol simulator shall be disconnected.
- g) A GNSS protocol simulator shall be connected, providing position information for a position B.
- h) The vessel's own position shall be confirmed by observation on the chart and marked.
- i) The AIS protocol simulator shall be reconnected in addition to the already connected GNSS protocol simulator.
- j) The vessel's own position shall be confirmed by observation on the chart. It shall be noted whether AIS or GNSS receiver position is used.
- k) The AIS protocol simulator shall provide a higher quality position information (DGNSS) for position A.
- l) The vessel's own position shall be confirmed by observation on the chart. It shall be noted whether AIS or GPS receiver position is used.
- m) GNSS protocol simulator shall be set to differential mode (DGPS).
- n) The vessel's own position shall be confirmed by observation on the chart. It shall be noted whether AIS or GPS receiver position is used.
- o) The result obtained shall be compared to the required test results in paragraph 3 in order to prove compliance with the requirement.

3. Required test result

Inland ECDIS shall consider whether there might be more than one position source of different quality.

Article 5.24 **Configuration of interfaces**

1. Reference

This clause refers to Part I, Chapter 2, Article 2.07(2).

2. Test method

- a) This clause only applies in the event that the manufacturer implements a ROT display.
- b) The test shall be performed in a laboratory.
- c) The Inland ECDIS shall be set to the standard operation setup as defined in Article 4.02(3) of this Part.
- d) A recorded real-life scenario ("scenario 01") shall be played back and fed into the Inland ECDIS.
- e) The manufacturer shall provide a complete and final list of all sensors, actors and signals, intended to be connected to the Inland ECDIS.
- f) Each of these sensors, actors and signals shall be connected to the Inland ECDIS consecutively.
- g) Each sensor, actor and signal shall be configured.
- h) The result obtained shall be compared to the required test results in paragraph 3(a) in order to prove compliance with the requirement.
- i) If a rate of turn indicator (ROT) is intended to be connected to the Inland ECDIS:
The question of whether a digital interface is applied and whether it is designed pursuant to document referred to in (3)(b) shall be checked.
- j) The result obtained shall be compared to the required test results in paragraph 3(b) in order to prove compliance with the requirement.
- k) The length of the scale shall be measured with an appropriate measurement tool (e.g. a ruler). The scale shall be compared to the required test results in paragraph 3(c) and (d) in order to prove compliance with the requirement.
- l) A variable voltage source with an output impedance of 100 Ohm shall be connected to the Inland ECDIS.
- m) The scale shall be set to 90 deg/min.
- n) The variable voltage source shall be set to 20 mV, 40 mV, 200 mV, 400 mV, 1,2 V, 1,8 V.
- o) If the Inland ECDIS provides a digital interface for ROT, appropriate NMEA strings with values of 1 deg/min, 2 deg/min, 10 deg/min, 20 deg/min, 60 deg/min, and 90 deg/min shall be fed into the interface consecutively.
- p) The indication of the ROT shall be compared to the required test results in paragraph 3(e) in order to prove compliance with the requirement.
- q) The scale shall be set to 300 deg/min.
- r) The variable voltage source shall be set to 20 mV, 40 mV, 200 mV, 2,0 V, 4,0 V, 6,0 V.

- s) If the Inland ECDIS provides a digital interface for ROT only, appropriate NMEA strings with values of 1 deg/min, 2 deg/min, 10 deg/min, 100 deg/min, 200 deg/min, and 300°/min, shall be fed into the interface consecutively.
 - t) The indication of the ROT shall be compared to the required test results in paragraph 3(e) in order to prove compliance with the requirement.
 - u) A negative analogue voltage of -1,2 V or a negative digital value of -60 deg/min shall be fed into the interface.
 - v) The direction of the indication shall be compared to the required test results in paragraph 3(f) in order to prove compliance with the requirement.
 - w) An analogue voltage of 0.67 mV or a negative digital value 0,3 deg/min shall be fed into the interface.
 - x) The indication of the ROT shall be compared to the required test results in paragraph 3(g) in order to prove compliance with the requirement.
 - y) An analogue voltage of 0,0 V or a negative digital value 0,0 deg/min shall be fed into interface.
 - z) The indication of the ROT shall be compared to the required test results in paragraph 3(h) in order to prove compliance with the requirement.
 - aa) An analogue voltage of 1,2 V or a negative digital value 60 deg/min shall be fed into the interface.
 - bb) The voltage shall be increased to 1,212 V (60,6 deg/min).
 - cc) The indication of the ROT shall be compared to the required test results in paragraph 3(i) in order to prove compliance with the requirement.
3. Required test result
- a) It shall be possible to configure each interface for the connected sensor, actor and signal. Each interface shall comply with existing interface specifications.
 - b) When connecting a ROT to the Inland ECDIS, the following requirement shall be fulfilled: a digital interface shall be designed pursuant to European Standards (REF#EN-61162, REF#EN-61162-1, REF#EN-61162-2 and REF#EN-61162-3).
 - c) The rate of turn shall be indicated on a linear graduated scale with the zero point situated in the middle. It shall be possible to read the direction and extent of the rate of turn with the necessary accuracy. Indicators other than needle indicators and bar-graphs shall not be permitted. Digital-only indicators will not be accepted.
 - d) The indicator scale shall be at least 20 cm long and may be circular or rectilinear. Rectilinear scales may be arranged horizontally only.
 - e) The indication of the rate of turn shall be equivalent to an analogue voltage of 20 mV/deg/min. The indicated rate of turn shall not differ by more than 2 % from the measurable maximum value or by more than 10 % from the actual value; whichever is the greater.
 - f) Polarity shall be positive when the vessel is turning to starboard and negative when it is turning to port.
 - g) The operating threshold shall not exceed 0,3 deg/min.
 - h) Zero error shall not exceed 1 deg/min at temperatures from 0 °C to +40 °C.
 - i) The operating threshold shall be less than or equal to a change in angular speed equivalent to 1 % of the indicated value.

Article 5.25

Documentation

1. Reference

This clause refers to Part I, Chapter 2, Article 2.10(2).

2. Test method

- a) The test shall be performed in a laboratory.
- b) The manufacturer shall provide appropriate installation and maintenance manuals as well as a user manual.
- c) The manuals shall be checked by visual inspection with respect to the required test results in paragraph 3 in order to prove compliance with the requirement.
- d) The manufacturer shall provide a document that comprises a statement about supported languages of the user interface.

3. Required test result

- a) The documentation (manuals) shall contain the following comprehensive information on:
 - i) the inland ECDIS,
 - ii) the installation,
 - iii) the operation,
 - iv) the service of the Inland ECDIS.
- b) The presentation of user-relevant information shall be clear, understandable and without unnecessary technical terms.
- c) The user manual shall be available, preferably in all supported languages of the user interface, but shall be available at least in the English language.
- d) The technical system description shall be available at least in the English language.
- e) The manufacturer's documentation shall identify the nominal viewing distance for the screen.

Article 5.26

Interfaces

1. Reference

This clause refers to Part I, Chapter 2, Article 2.10(3).

2. Test method

- a) The test shall be performed in a laboratory.
- b) The manufacturer shall provide appropriate information and documentation for each interface of the Inland ECDIS.
- c) The information for each interface shall be inspected and checked for completeness and correctness.
- d) The result obtained shall be compared to the required test results in paragraph 3 in order to prove compliance with the requirement.

3. Required test result

All interfaces of the Inland ECDIS shall be documented correctly and completely.

CHAPTER 6
ADDITIONAL OPERATIONAL AND PERFORMANCE REQUIREMENTS,
METHODS OF TEST AND
REQUIRED TEST RESULTS FOR INLAND ECDIS IN INFORMATION MODE

This Chapter contains additional requirements specific to Inland ECDIS in information mode. The requirements for “all modes” (Chapter 5) also apply for Inland ECDIS in information mode.

Article 6.01
Operation

1. Reference

This clause refers to Part I, Chapter 2, Article 2.04(1).

2. Test method

- a) The test shall be performed in a laboratory.
- b) The Inland ECDIS shall be set to the standard operation setup as defined in Article 4.02(3) of this Part.
- c) An IENC (“chart 01”) shall be loaded into the Inland ECDIS.
- d) The GNSS protocol simulator shall be configured in such a way that the vessel’s own position follows a given track.
- e) It shall be inspected regarding whether the chart picture moves automatically and whether the displayed section matches the actual surrounding / user-selected range.
- f) The result obtained shall be noted in the test report.
- g) The result obtained shall be compared to the required test results in paragraph 3 in order to prove compliance with the requirement.

3. Required test result

The Inland ECDIS may be connected to a positioning sensor to move the chart picture automatically and to display the section of the chart matching the actual surrounding, namely in the user-selected range.

Article 6.02
Screen dimensions

1. Reference

This clause refers to Part I, Chapter 2, Article 2.06(3).

2. Test method

- a) The test shall be performed in a laboratory.
- b) The Inland ECDIS shall be set to the standard operation setup as defined in Article 4.02(3) of this Part.

- c) An IENC ("chart 01") shall be loaded into the Inland ECDIS.
 - d) The screen dimension shall be measured with an appropriate measurement tool (e.g. a ruler).
 - e) The result obtained shall be compared to the required test results in paragraph 3 in order to prove compliance with the requirement.
3. Required test result
- The screen diagonal shall be equal to or larger than 199 mm (7.85 inches).

Article 6.03 **Screen resolution**

1. Reference
This clause refers to Part I, Chapter 2, Article 2.06(4).
2. Test method
Not tested, as it is a recommendation only.
3. Required test result
Not applicable.

Article 6.04 **Malfunctions**

1. Reference
This clause refers to Part I, Chapter 2, Article 2.08(2).
2. Test method
 - a) The test shall be performed in a laboratory.
 - b) The Inland ECDIS shall be set to the standard operation setup as in Article 4.02(3) of this Part.
 - c) The GNSS protocol simulator shall send position data to the Inland ECDIS. The vessel's own position shall be confirmed by observation in the chart and marked.
 - d) The GNSS protocol simulator shall be stopped sending position data.
 - e) The behaviour of the Inland ECDIS shall be compared to the required test results in paragraph 3 in order to prove compliance with the requirement.
 - f) The GNSS protocol simulator shall retransmit position data. The vessel's own position shall be confirmed by observation in the chart and marked.
 - g) The GNSS protocol simulator shall be disconnected from the Inland ECDIS.
 - h) The behaviour of the Inland ECDIS shall be compared to the required test results in paragraph 3 in order to prove compliance with the requirement.

- i) The AIS protocol simulator shall be configured in such a way that the vessel's own position is shown in the centre of the screen.
- j) The loss of the VHF antenna of the Inland AIS device shall be simulated by configuring the AIS protocol simulator to send the appropriate data to the Inland ECDIS.
- k) The behaviour of the Inland ECDIS shall be compared to the required test results in paragraph 3 in order to prove compliance with the requirement.
- l) The AIS protocol simulator shall be stopped sending data.
- m) The AIS protocol simulator shall be disconnected from the Inland ECDIS.
- n) The behaviour of the Inland ECDIS shall be compared to the required test results in paragraph 3 in order to prove compliance with the requirement.
- o) The Inland ECDIS shall be connected to a heading protocol simulator as described in Article 8.05 of this Part. The vessel's own heading shall be confirmed by observation in the chart.
- p) The heading protocol simulator shall be stopped in sending heading data.
- q) The behaviour of the Inland ECDIS shall be compared to the required test results in paragraph 3 in order to prove compliance with the requirement.
- r) The heading protocol simulator shall be stopped sending data. The vessel's own heading shall be confirmed by observation in the chart.
- s) The heading protocol simulator shall be disconnected from the Inland ECDIS.
- t) The behaviour of the Inland ECDIS shall be compared to the required test results in paragraph 3 in order to prove compliance with the requirement.

3. Required test result

The Inland ECDIS shall send a suitable alarm or warning indicator of missing input from – if connected – GNSS receiver, AIS and heading device.

Article 6.05 **Documentation**

1. Reference

This clause refers to Part I, Chapter 2, Article 2.10(2).

2. Test method

- a) The test shall be performed in a laboratory.
- b) The manufacturer's documentation shall be checked for a statement as required by paragraph 3 in order to prove compliance with the requirement.

3. Required test result

The manufacturer's documentation shall include information that the software, if sold as a standalone product without hardware, may only be used as an Inland ECDIS if the hardware fulfils the requirements of Part I.

Article 6.06
Interfaces

1. Reference

This clause refers to Part I, Chapter 2, Article 2.10(3).

2. Test method

- a) The test shall be performed in a laboratory.
- b) The manufacturer's documentation shall be checked for a statement as required by paragraph 3 in order to prove compliance with the requirement.

3. Required test result

The manufacturer's system documentation shall include the information that the system includes test procedures and signal indicators according to Part I, Chapter 2, Article 2.08.

CHAPTER 7
ADDITIONAL OPERATIONAL AND PERFORMANCE REQUIREMENTS,
METHODS OF TEST AND
REQUIRED TEST RESULTS FOR INLAND ECDIS IN NAVIGATION MODE

This Chapter contains additional requirements specific to Inland ECDIS in navigation mode. The requirements for “all modes” (Chapter 5) also apply for Inland ECDIS in navigation mode.

Article 7.01
Updates

1. Reference

This clause refers to Part I, Chapter 2, Article 2.02(1).

2. Test method

- a) The test shall be performed in a laboratory.
- b) The Inland ECDIS shall be set to the standard operation setup as defined in Article 4.02(4) of this Part.
- c) The load of a chart (“chart 02”) shall be initiated manually.
- d) The behaviour of the Inland ECDIS shall be compared to the required test results in paragraph 3(a) in order to prove compliance with the requirement.
- e) A manual update process shall be initiated.
- f) The behaviour of the Inland ECDIS shall be compared to the required test results in paragraph 3(b) in order to prove compliance with the requirement.
- g) An automatic update shall be applied.
- h) The performance of the navigation display shall be inspected.
- i) The result obtained shall be compared to the required test results in paragraph 3(c) in order to prove compliance with the requirement.

3. Required test result

- a) The manual loading of charts shall not be possible in navigation mode.
- b) The manual updating of charts shall not be possible in navigation mode.
- c) The automatic updating shall not downgrade the performance of the navigation display.

Article 7.02
Image positioning and orientation

1. Reference

This clause refers to Part I, Chapter 2, Article 2.03(1).

2. Test method

- a) This test shall be conducted aboard a vessel under way.
- b) The Inland ECDIS shall be set to the standard operation setup as defined in Article 4.02(5) of this Part.

- c) The positioning of the chart, motion, orientation and the own vessel's position in the presentation of the chart in the Inland ECDIS shall be compared to the required test results in paragraph 3(a) in order to prove compliance with the requirement
 - d) The Inland ECDIS shall be set to mode true motion, north-up.
 - e) The behaviour of the Inland ECDIS shall be compared to the required test results in paragraph 3(b) in order to prove compliance with the requirement.
3. Required test result
- a) The chart shall be automatically positioned and oriented in the relative motion, head-up display mode. The own vessel's position in the screen may be centred or off-centred.
 - b) When the Inland ECDIS uses orientations other than head-up orientation, the Inland ECDIS shall switch to information mode.

Article 7.03
Screen orientation, chart orientation, positioning and shifting

1. Reference
- This clause refers to Part I, Chapter 2, Article 2.03(2).
2. Test method
- a) This test shall be conducted aboard a vessel under way.
 - b) The Inland ECDIS shall be set to the standard operation setup as defined in Article 4.02(5) of this Part.
 - c) The size, position and orientation of the chart and radar image under different manoeuvre situations shall be compared to the required test results in paragraph 3(a) in order to prove compliance with the requirement.
 - d) The Inland ECDIS shall be set to "centred".
 - e) Range rings shall be switched on.
 - f) The own vessel's position in the presentation of the chart in the Inland ECDIS shall be compared to the required test results in paragraph 3(b) in order to prove compliance with the requirement.
 - g) The Inland ECDIS shall be set to "off centred".
 - h) The own vessel's position in the presentation of the chart in the Inland ECDIS shall be compared to the required test results in paragraph 3(b) in order to prove compliance with the requirement.
3. Required test result
- a) The chart and the radar image shall be matching in size, position and orientation.
 - b) The vessel's own position shall be shown in the centre point of the range rings and visible in the display area.

Article 7.04
Position and heading of the own vessel

1. Reference

This clause refers to Part I, Chapter 2, Article 2.03(3).

2. Test method

- a) This test shall be conducted aboard a vessel under way.
- b) The Inland ECDIS shall be set to the standard operation setup as defined in Article 4.02(5) of this Part.
- c) The visibility, position and orientation of the heading line shall be compared to the required test results in paragraph 3(a) in order to prove compliance with the requirement.
- d) The colour of the heading line when intersecting other objects shall be compared to the required test results in paragraph 3(a) in order to prove compliance with the requirement.
- e) It shall be inspected as to whether there are means of switching off the heading line in order to obtain the required test results in paragraph 3(a) in order to prove compliance with the requirement.
- f) The offset between position sensor and radar sensor shall be set to an arbitrary position offset.
- g) The position of chart and radar image shall be compared to the required test results in paragraph 3(b) in order to prove compliance with the requirement.

3. Required test result

- a) The heading line shall always be visible and shall represent the heading of the own vessel.
- b) It shall be possible to correct an offset error (distance between the positions of the position sensor antenna and the radar antenna).

Article 7.05
Display of SENC information

1. Reference

This clause refers to Part I, Chapter 2, Article 2.03(4).

2. Test method

- a) This test shall be conducted aboard a vessel under way.
- b) The Inland ECDIS shall be set to the standard operation setup as defined in Article 4.02(5) of this Part.
- c) The Inland ECDIS shall be set to colour combination day.
- d) The distinguishability of the colours on the radar picture and chart shall be compared to the required test results in paragraph 3(a) in order to prove compliance with the requirement.
- e) The Inland ECDIS shall be set to colour combination dusk.
- f) The distinguishability of the colours on the radar picture and chart shall be compared to the required test results in paragraph 3(a) in order to prove compliance with the requirement.

- g) The Inland ECDIS shall be set to colour combination night.
 - h) The distinguishability of the colours on the radar picture and chart shall be compared to the required test results in paragraph 3(a), in order to prove compliance with the requirement.
 - i) The presentation of the chart and radar picture and the presentation of the heading line of the Inland ECDIS in all scales shall be compared to the required test results in paragraph 3(b) in order to prove compliance with the requirement
 - j) The presentation of chart information shall be compared to the required test results in paragraph 3(c) in order to prove compliance with the requirement.
 - k) The own vessel's contour and safety contour shall be switched on.
 - l) The result obtained shall be compared to the required test results in paragraph 3(d) in order to prove compliance with the requirement.
 - m) The Inland ECDIS shall be set to minimum scale and then switched until maximum scale, step-by-step consecutively.
 - n) In each scale an inspection shall take place to ensure that:
 - i) the matching of radar picture and chart is correct;
 - ii) the heading line is always visible;
 - iii) the presentation of chart information does not mask or degrade important parts of the radar picture;
 - iv) the own vessel's contour and the safety contours are presented correctly; and
 - v) the elements as defined in Part I Chapter 2, Article 2.01(1)(b)(i), 1st to 7th indent are not obscured by other objects.
 - o) The result obtained shall be compared to the required test results in paragraph 3(e) in order to prove compliance with the requirement.
3. Required test result
- a) The radar picture is clearly distinguishable from the chart, independent of the chosen colour table.
 - b) The chart and radar picture presentation shall match in all scales and the heading line shall always be visible.
 - c) The presentation of chart information shall not mask or degrade important parts of the radar picture.
 - d) The own vessel's contour and the safety contours shall be presented correctly.
 - e) The following elements shall always be visible and shall not be obscured by other objects:
 - i) bank of waterway (at mean water level);
 - ii) construction (e.g. groin, longitudinal control dam, training wall – any facility that is considered a hazard to navigation);
 - iii) contours of locks and dams;
 - iv) boundaries of the fairway/navigation channel (if defined);
 - v) isolated dangers in the fairway/navigation channel under water;
 - vi) isolated dangers in the fairway/navigation channel above water level, such as bridges, overhead cables, etc.;
 - vii) official aids-to-navigation (e.g. buoys, beacons, lights, notice marks);
 - viii) heading line;
 - ix) bearing line;

- x) range rings;
- xi) navigation lines;
- xii) P-lines;
- xiii) buoys;
- xiv) Inland AIS symbols of other vessels;
- xv) Inland AIS labels of other vessels (if displayed);
- xvi) Sign and Marking information (including AIS AtoN).

Article 7.06
Display of radar information

1. Reference

This clause refers to Part I, Chapter 2, Article 2.03(8).

2. Test method

- a) This test shall be completed aboard a vessel under way.
- b) The Inland ECDIS shall be set to the standard operation setup as defined in Article 4.02(5) of this Part.
- c) The radar image and the position from the position sensor shall be adjusted for the conning position.
- d) The result obtained shall be compared to the required test results in paragraph 3(a) in order to prove compliance with the requirement.
- e) Additional navigational information and tracking and tracing symbols shall be displayed. The presentation of radar information shall be compared to the required test results in paragraph 3(b) in order to prove compliance with the requirement.
- f) Radar shall be switched off. The mode indication shall be compared to the required test results in paragraph 3(c) in order to prove compliance with the requirement.
- g) Radar shall be switched on again. The mode indication shall be compared to the required test results in paragraph 3(c) in order to prove compliance with the requirement.
- h) The dimensions, resolution and attributes of the radar presentation shall be checked against Part I.
- i) The result obtained shall be compared to the required test results in paragraph 3(d) in order to prove compliance with the requirement.
- j) The chart shall be switched off.
- k) The result obtained shall be compared to the required test results in paragraph 3(e) in order to prove compliance with the requirement.
- l) The chart shall be switched on again.
- m) The number of colours used and intensity levels in the representation of the radar picture shall be compared to the required test results in paragraph 3(f) in order to prove compliance with the requirement.
- n) Trails shall be switched on.
- o) The manufacturer shall declare whether relative or absolute or both types of trails are implemented. The statement shall be noted in the test report.
- p) The colours of trails shall be compared to the required test results in paragraph 3(h) in order to prove compliance with the requirement.

- q) The following tests shall be performed in a laboratory or aboard a vessel under way.
 - r) For Inland ECDIS in system configuration 2, the requirements relative to the display and the pictures for radar and rate of turn indicators as defined in REF#CESNI-ESTRIN (respectively in Annex 9, Section I, Article 3 and in Annex 9, Section II) shall be fulfilled.
 - s) The result obtained shall be compared to the required test results in paragraph 3(i) of this Part in order to prove compliance with the requirement.
 - t) For Inland ECDIS in system configurations 3 and 4, test against all requirements of the standards for radar equipment and rate of turn indicators as defined in Part I, shall be performed.
 - u) The result obtained shall be compared to the required test results in Article 7.06(3)(j) of this Part in order to prove compliance with the requirement.
 - v) Note: The results of test method in Article 7.08 position accuracy shall be checked and compared to the required test results in paragraph 3(g).
3. Required test result
- a) The radar image and the position from the position sensor shall both be adjustable for the antenna offset to a common reference position, e.g. conning position.
 - b) Any additional navigational information and tracking and tracing symbols shall in no way degrade the display of the original radar content.
 - c) The radar image representation is mandatory for operation. When the radar image is switched off, the system shall fall back to information mode. An alarm shall be given. The switching shall always be possible by manual action.
 - d) The dimensions, resolution and attributes of the radar presentation shall fulfil the relevant radar requirements (as specified in Part I).
 - e) It shall be possible to switch off the chart or any other information layer, and to display the radar picture, only by one easily accessible control element or menu area.
 - f) The radar information shall be clearly distinguishable from the SENC information independently of the chosen colour table. The actual radar picture shall be represented only in monochrome colour with different intensities.
 - g) If the quality and plausibility monitoring of the Inland ECDIS detect that the chart cannot be oriented and/or positioned with the specified accuracy, an alarm shall be presented on the display and the chart shall be switched off automatically. If there is no radar signal, the information mode shall be displayed and an alarm shall be activated.
 - h) Trails shall be true or relative. Trails for radar echoes should have the same colour as the radar echoes. It is also possible to show the trails in a different colour from the colour of the radar echoes, but the colour of the trails should not dominate the radar echoes. The brightness of the trails shall always be lower than the radar echoes, no matter which colour or colour combination is used.
 - i) For Inland ECDIS in system configuration 2, the radar picture shall fulfil the requirements relative to the display and the pictures for radar and rate of turn indicators as defined in Part I.
 - j) For Inland ECDIS in system configuration 3 and 4, all requirements of the standards for radar equipment and rate of turn indicators as defined in Part I shall be fulfilled.

Article 7.07
Data and display accuracy

1. Reference

This clause refers to Part I, Chapter 2, Article 2.03(11).

2. Test method

- a) This test shall be conducted aboard a moored vessel.
- b) The Inland ECDIS shall be set to the standard operation setup as defined in Article 4.02(5) of this Part.
- c) The Inland ECDIS shall be set to the smallest display range (highest zoom factor) and the Inland ECDIS shall be verified for any indications.
- d) The result obtained shall be compared to the required test results in paragraph 3(a) in order to prove compliance with the requirement.
- e) The range shall be set to 500 m. The static offset between radar picture and chart image shall be corrected as best as possible. The remaining error shall be compared to the required test results in paragraph 3(b) and (c) in order to prove compliance with the requirement.
- f) The permissions to adjust the offset values between the positions of the position sensor and the radar antenna of the vessel shall be inspected and compared to the required test results in paragraph 3(d) in order to prove compliance with the requirement.
- g) The resolution and accuracy shall be compared to the display. There shall be a check on whether better values than those of the chart data are suggested.
- h) The result obtained shall be compared to the required test results in paragraph 3(e) in order to prove compliance with the requirement.
- i) Note: the static offset error cannot be tested in all ranges up to 2 000 m in a repeatable and objective way. For a usual resolution of a screen in a range of 2 000 m, a distance of 5 m corresponds to just a few pixels.

3. Required test result

- a) The Inland ECDIS shall send an indication as to whether the display uses a smaller display range (higher zoom factor) than the accuracy of the IENC data offers (over-scale indication).
- b) The static offset, i.e. the error between the whole radar picture and chart image, shall be less than ± 5 m in all ranges up to 2000 m.
- c) The chart position shall match the radar image. Assuming an absolute position's input, the permissible static difference between actual radar position and displayed radar centre shall not exceed 5 m.
- d) It shall be possible for a system administrator to only adjust the offset values between the positions of the position sensor antenna and the radar antenna of the vessel so that the SENC display matches the radar image.
- e) Resolution and accuracy shall at least be the same as those of the display, but may not suggest better values than those of the chart data.

Article 7.08
Position accuracy

1. Reference

This clause refers to Part I, Chapter 2, Article 2.03(12).

2. Test method

a) The first part of the test (clause b and c) shall be performed aboard a vessel. The second part of the test (clause d and following) shall be performed in laboratory.

b) The Inland ECDIS shall be set to the standard operation setup as defined in Article 4.02(5) of this Part.

c) Update period position:

The update time of the position estimate shall be compared to the required test results in paragraph 3(a) in order to prove compliance with the requirement.

d) The Inland ECDIS shall be set to the standard operation setup as defined in Article 4.02(4) of this Part.

e) Horizontal error:

The next NMEA messages which are outputted by the GNSS and according to REF#EN-61162-2 shall be sent to the Inland ECDIS:

- Time, position, and fix related data (GGA – “\$--GGA”);
- GNSS satellite fault detection (GBS – “\$--GBS”);
- GPS DOP and active satellites (GSA – “\$--GSA”).

The configuration shall be such that all requirements can be met without any exceeding or falling short of thresholds. The GNSS receiver shall be the source for position information for the Inland ECDIS.

A GNSS satellite fault detection (GBS) test sentence according to REF#EN-61162-1 shall be fed into the Inland ECDIS. The expected horizontal error shall be calculated on the basis of the fields “expected error in longitude” and “expected error in latitude” according to the following formula:

$$\text{expected horizontal error} = \sqrt{(\text{expected error in latitude})^2 + (\text{expected error in longitude})^2}$$

The result obtained shall be compared to the required test results in paragraph 3(b).

The expected error in latitude and longitude shall be set consecutively to

- (7 m | 7 m) resulting in an expected error of 9,89 m and
- (8 m | 8 m) resulting in an expected error of 11,31 m.

The expected horizontal error and the indication of Inland ECDIS shall be compared to the required test results in paragraph 3(b).

f) Too few satellites in use error:

A GGA test sentence according to REF#EN-61162-2, containing the position, time of position fix, GNSS quality and other information, shall be fed into the Inland ECDIS. The field “number of satellites in use” shall be compared to the required test results in paragraph 3(c).

The number of satellites shall be set to 3. The field “number of satellites in use” and the indication of Inland ECDIS shall be compared to the required test results in paragraph 3(c).

- g) PDOP error:
A GSA test sentence according to REF#ETSI-303676, containing satellite and DOP information, shall be fed into the Inland ECDIS. The value of the field "PDOP" shall be compared to the required test results in paragraph 3(d).
The value of the field "PDOP" shall be set to 6. The value of the field "PDOP" and the indication of Inland ECDIS shall be compared to the required test results in paragraph 3(d).
- h) HDOP error:
A GSA test sentence according to REF#EN-61162-2, containing satellite and DOP information, shall be fed into the Inland ECDIS. The value of the field "HDOP" shall be compared to the required test results in paragraph 3(e).
The value of the field "HDOP" shall be set to 4. The value of the field "HDOP" and the indication of Inland ECDIS shall be compared to the required test results in paragraph 3(e).
- i) GPS quality indicator error:
A GGA test sentence according to REF#EN-61162-2, containing the position, time of position fix, GNSS quality and other information, shall be fed into the Inland ECDIS. The field "GPS quality indicator" shall be compared to the required test results in paragraph 3(f).
The field "GPS quality indicator" shall be set to 6, 7 and 8 consecutively. The field "GPS quality indicator" and the indication of Inland ECDIS shall be compared to the required test results in paragraph 3(f).
The field "GPS quality indicator" shall be set to 2 and after 60 seconds set to 1. The field "GPS quality indicator" and the indication of Inland ECDIS shall be compared to the required test results in paragraph 3(f).
- j) Position Accuracy (PA) flag error:
An Inland AIS data stream containing VDO (AIS VHF data-link own-vessel report) message type 1 shall be connected to Inland ECDIS.
The field "PA flag" shall be set to 1. Inland AIS shall be the source for position information for the Inland ECDIS.
The field "PA flag" shall be compared to the required test results in paragraph 3(g).
The field "PA flag" shall be set to 0. The field "PA flag" and the indication of Inland ECDIS shall be compared to the required test results in paragraph 3(g).

3. Required test result

- a) A new position estimate shall at least be available with every revolution of the radar antenna.
- b) The expected horizontal error shall be less than 10 m and no warning or alarm shall be indicated.
If the expected horizontal error exceeds the threshold of 10 m for more than 30 seconds, the Inland ECDIS shall indicate an appropriate positioning warning to the user.
- c) The number of satellites in use shall be greater than 3 satellites and no warning or alarm shall be indicated.
If the number of satellites in use is less than 4 for more than 30 seconds, the Inland ECDIS shall indicate an appropriate positioning warning to the user.

- d) The value of the field "PDOP" shall be smaller than 6 and no warning or alarm shall be indicated.
 If the value of the field "PDOP" is greater than or equal to 6 for more than 30 seconds, the Inland ECDIS shall indicate an appropriate positioning warning to the user.
- e) The value of the field "HDOP" shall be smaller than 4 and no warning or alarm shall be indicated.
 If the value of the field "HDOP" is greater than or equal to 4 for more than 30 seconds, the Inland ECDIS shall indicate an appropriate positioning warning to the user.
- f) GPS quality indicator shall be 1 or 2 and no warning or alarm shall be indicated.
 If GPS quality indicator is 6, 7 or 8 for more than 30 seconds, the Inland ECDIS shall indicate an appropriate positioning alarm to the user.
 If GPS quality indicator is 2 and comes back to 1 for more than 60 seconds, the Inland ECDIS shall indicate an appropriate positioning warning to the user.
- g) The value of the field "PA flag" shall equals 1 and no warning or alarm shall be indicated.
 If the value of the field "PA flag" equals 0 for more than 60 seconds, the Inland ECDIS shall indicate an appropriate positioning warning to the user.
 If the quality and plausibility monitoring of the Inland ECDIS detect that the chart cannot be oriented and/or positioned with the specified accuracy, an alarm shall be presented on the display and the chart shall be switched off automatically. If there is no radar signal, the information mode shall be displayed, and an alarm shall be activated.

Article 7.09 ***Heading accuracy***

1. Reference

This clause refers to Part I, Chapter 2, Article 2.03(13).

2. Test method

- a) This test shall be conducted aboard a vessel.
- b) The Inland ECDIS shall be set to the standard operation setup as defined in Article 4.02(5) of this Part.
- c) Update period heading:
 The update time of the heading estimate shall be compared to the required test results in paragraph 3(a) in order to prove compliance with the requirement.
- d) Orientation of chart and radar image:
 The offset between vessel heading direction and radar heading shall be set to less than 1 degree.
- e) EBL shall be set to 1°.
- f) The radar image shall be switched on.
- g) The orientation of chart and radar image shall be compared to the required test results in paragraph 3(b) in order to prove compliance with the requirement.

- h) Static directional error:
The heading line of the vessel shall be aligned with a fixed object in distance of about 600 m visually. The object shall be identified in the chart. The bearing match between the radar image and chart shall be measured with the EBL.
 - i) The result obtained shall be compared to the required test results in paragraph 3(c) in order to prove compliance with the requirement.
 - j) Heading angle estimation:
The vessel shall pass arbitrarily chosen objects in different ranges. Each chosen object shall be identified in the chart. The difference between heading angle estimate and radar heading direction shall be measured with EBL. The results obtained shall be compared to the required test results in paragraph 3(d) in order to prove compliance with the requirement.
3. Required test result
- a) A new heading estimate shall at least be available with every revolution of the radar antenna.
 - b) The chart and radar image shall have the same orientation.
 - c) The static directional error between heading line and chart orientation shall be less than $\pm 0,5$ degree.
 - d) The average heading angle estimation shall not deviate more than 1 degree from the radar heading direction and shall cover all systematic errors.

Article 7.10 **Operation**

1. Reference

This clause refers to Part I, Chapter 2, Article 2.04(1).

2. Test method

- a) This test shall be conducted aboard a vessel under way.
- b) The Inland ECDIS shall be set to the standard operation setup as defined in Article 4.02(5) of this Part.
- c) The indication of navigation mode shall be confirmed by observation.
- d) The Inland ECDIS shall be switched from navigation mode to information mode manually.
- e) It shall be confirmed by observation that navigation mode is not displayed anymore.
- f) Inspection shall take place on how many user actions are necessary for this operation.
- g) The Inland ECDIS shall be switched from information mode to navigation mode manually.
- h) The result obtained shall be compared to the required test results in paragraph 3(a) in order to prove compliance with the requirement.
- i) Navigation mode shall be switched off. Inspection shall take place on whether this can happen unintentionally and whether there are appropriate measures implemented to prevent inadvertent switching off.
- j) The result obtained shall be compared to the required test results in paragraph 3(b) in order to prove compliance with the requirement.

- k) The IENC shall be switched off.
 - l) Inspection shall take place on how many user actions are necessary for this operation.
 - m) The IENC shall be switched on again.
 - n) The result obtained shall be compared to the required test results in paragraph 3(c) in order to prove compliance with the requirement.
 - o) Radar information shall be switched off.
 - p) Inspection shall take place on how many user actions are necessary for this operation.
 - q) Radar information shall be switched on again.
 - r) The result obtained shall be compared to the required test results in paragraph 3(d) in order to prove compliance with the requirement.
 - s) In case the device supports other communication links for the orientation and positioning of other vessels on the screen, appropriate additional tests shall be set up on the basis of the description and documentation provided by the manufacturer of the Inland ECDIS. These clauses shall be documented completely in the test report. The results obtained shall be compared to the required test results in paragraph 3(e) in order to prove compliance with the requirement.
3. Required test result
- a) It shall be possible to switch from navigation mode to information mode and back and the correct mode shall be displayed.
 - b) Suitable measures shall be implemented to prevent the inadvertent switching off of the navigation mode.
 - c) It shall be possible to temporarily switch off the IENC by a single user action.
 - d) It shall be possible to temporarily switch off the radar information by a single user action.
 - e) Information regarding the position and orientation of other vessels, gathered by other communication links than the own radar, may be displayed only if they are up to date (nearly real-time) and meet the accuracy that is required for the support of tactical and operational navigation.

Article 7.11 ***Ergonomics of control elements***

1. Reference

This clause refers to Part I, Chapter 2, Article 2.04(2).

2. Test method

- a) The test shall be performed in a laboratory.
- b) The Inland ECDIS shall be set to the standard operation setup as defined in Article 4.02(4) of this Part.
- c) The symbols of the control elements shall be inspected for legibility.
- d) The result obtained shall be compared to the required test results in paragraph 3(a) in order to prove compliance with the requirement.

- e) The brightness and the illumination of the control elements shall be set to any arbitrary values, including minimum and maximum value. The behaviour shall be compared to the required test results in paragraph 3(b) in order to prove compliance with the requirement.
 - f) Each control element shall be inspected as to whether it is necessary.
 - g) The results obtained shall be compared to the required test results paragraph 3(c) in order to prove compliance with the requirement.
 - h) Inspection will take place to see whether it is possible to switch off the Inland ECDIS unintentionally and whether there are appropriate measures implemented to prevent inadvertent switching off.
 - i) The result obtained shall be compared to the required test results in paragraph 3(d) in order to prove compliance with the requirement.
3. Required test result
- a) The symbols of the control elements shall be legible under all conditions that may exist in a wheelhouse.
 - b) The brightness and the illumination of the control elements shall be adjustable to any arbitrary value.
 - c) There shall not be more control elements than required.
 - d) The ON/OFF switch shall have a provision to prevent switching off inadvertently.

Article 7.12
Input and editing of boatmasters' own chart entries

1. Reference

This clause refers to Part I, Chapter 2, Article 2.04(6).

2. Test method

- a) The test shall be performed in a laboratory.
- b) The Inland ECDIS shall be set to the standard operation setup as defined in Article 4.02(4) of this Part.
- c) A new own chart entry shall be created by introducing a single point-shaped object.
- d) The presentation of own chart entry shall be inspected to see whether it is distinguishable from the SENC data.
- e) The result obtained shall be compared to the required test results in paragraph 3(a) in order to prove compliance with the requirement.
- f) A new own chart entry shall be created by inserting a text.
- g) The behaviour of the Inland ECDIS shall be compared to the required test results in paragraph 3(b) in order to prove compliance with the requirement.
- h) A new own chart entry shall be created by drawing a line and polygon.
- i) The behaviour of the Inland ECDIS shall be compared to the required test results in paragraph 3(b) in order to prove compliance with the requirement.
- j) A new own chart entry shall be created by drawing a closed polygon (area).
- k) The behaviour of the Inland ECDIS shall be compared to the required test results in paragraph 3(b) in order to prove compliance with the requirement.

3. Required test result
 - a) It shall be possible to create and place own single point-shaped objects. This entry shall be distinguishable from the SENC data.
 - b) It shall not be possible to create and place another own object in navigation mode.

Article 7.13
Scales, Ranges/Range rings

1. Reference

This clause refers to Part I, Chapter 2, Article 2.04(7).

2. Test method

- a) This test shall be conducted aboard a vessel under way.
- b) The Inland ECDIS shall be set to the standard operation setup as defined in Article 4.02(5) of this Part.
- c) Display mode "all display" shall be activated. Cross profiles at the distance marks (at least 100 m marks) shall be displayed.
- d) The vessel shall be navigated to a 100 m distance mark (conning position) and stopped.
- e) The range shall be set from minimum range to maximum range step-by-step consecutively.
- f) For each range, the distance of range rings in relation to the cross profiles shall be compared to the required test results in paragraph 3(a) to (d) in order to prove compliance with the requirement.
- g) All VRMs shall be activated and the number available shall be noted in the test report.
- h) The result obtained shall be compared to the required test results in paragraph 3(e) in order to prove compliance with the requirement.
- i) All VRMs shall be switched off.
- j) The fixed range rings shall be switched on.
- k) The activation and the display of range rings and VRM shall be inspected and compared to the required test results in paragraph 3(f) in order to prove compliance with the requirement.
- l) The VRM shall be moved to different cross profiles. The corresponding displayed distance shall be inspected regarding increment and resolution and compared to the required test results in paragraph 3(g) in order to prove compliance with the requirement.
- m) All EBLs shall be activated and the number available shall be noted in the test report.
- n) All EBLs shall be switched off.
- o) EBL shall be activated.
- p) The functionality of EBL and VRM and their corresponding numerical displays shall be inspected for correctness using the cursor.
- q) The result obtained shall be compared to the required test results in paragraph 3(h) in order to prove compliance with the requirement.
- r) The fixed range rings shall be switched on with a range of 1200 m.

- s) VRM shall be switched on and shall be moved to the 1000 m ring.
- t) The accuracy of fixed range rings and VRM shall be maintained in both cases, with the display centred and off-centred. The numeric displayed values of the EBL and the VRM shall exactly match with the analogue positions of the EBL and the VRM (or correspond with the cursor coordinates).
- u) The result obtained shall be compared to the required test results in paragraph 3(i) in order to prove compliance with the requirement.
- v) EBL shall be switched on and shall be set to 0°, 90°, 180° and 270° consecutively.
- w) When set to 0° it shall be confirmed by observation whether EBL matches exactly the heading line.
- x) The resolution and increments of the numerical display shall be compared to the analogue values of EBL and VRM.
- y) The result obtained shall be compared to the required test results in paragraph 3(j) in order to prove compliance with the requirement.

3. Required test result

- a) The following distances of range rings shall be implemented:

Range	Range rings
500 m	100 m
800 m	200 m
1200 m	200 m
1600 m	400 m
2000 m	400 m
4000 m	1000 m
- b) Smaller and larger ranges shall have a minimum of four and a maximum of six range rings.
- c) Only the successive switchable ranges (scales) shall be implemented.
- d) The Inland ECDIS shall have fixed range rings.
- e) There shall be at least one VRM implemented.
- f) It shall be possible to switch on and off independently the fixed range meters on one hand and the VRM on another hand, and their display shall be clearly distinguishable.
- g) The position of the VRM and the corresponding displayed distance shall use the same increments and resolution.
- h) The functionality of VRM and the EBL, and the corresponding numerical display showing range and bearing, shall be correct in relation to the cursor position.
- i) All numeric displayed values of the EBL and the VRM shall exactly match with the analogue positions of the EBL and the VRM (or correspond with the cursor coordinates).
- j) The resolution and increments of the numerical display shall be identical to the analogue values of EBL and VRM.

Article 7.14
Inland ECDIS pre-sets (store/recall) in navigation mode

1. Reference

This clause refers to Part I, Chapter 2, Article 2.04(8).

2. Test method

- a) The test shall be performed in a laboratory.
- b) The Inland ECDIS shall be set to the standard operation setup as defined in Article 4.02(4) of this Part.
- c) The Inland ECDIS shall be (re-) started.
- d) After the Inland ECDIS has come up, the brightness shall be compared to the required test results in paragraph 3 in order to prove compliance with the requirement.

3. Required test result

After starting, the Inland ECDIS shall come up with a moderate brightness pre-set which is neither blinding in a dark environment nor making the picture indecipherable in a bright environment.

Article 7.15
Control elements

1. Reference

This clause refers to Part I, Chapter 2, Article 2.04(9).

2. Test method

- a) This test shall be conducted aboard a vessel under way.
- b) The Inland ECDIS shall be set to the standard operation setup as defined in Article 4.02(5) of this Part.
- c) The Inland ECDIS shall be inspected with regard to the permanent visibility of the sensor status (radar tuning and position quality).
- d) The result obtained shall be compared to the required test results in paragraph 3 in order to prove compliance with the requirement.

3. Required test result

The following function parameters shall always be visible:

- a) sensor status (radar tuning and position quality).

Article 7.16
Service functions

1. Reference

This clause refers to Part I, Chapter 2, Article 2.05(1).

2. Test method
 - a) The test shall be performed in a laboratory.
 - b) The Inland ECDIS shall be set to the standard operation setup as defined in Article 4.02(4) of this Part.
 - c) The service function “static correction of the chart position” shall be selected.
 - d) It shall be inspected to see whether this selection is possible.
 - e) The result obtained shall be compared to the required test results in paragraph 3 in order to prove compliance with the requirement.
 - f) The service function “static correction of the chart orientation” shall be selected.
 - g) It shall be inspected to see whether this selection is possible.
 - h) The result obtained shall be compared to the required test results in paragraph 3 in order to prove compliance with the requirement.
 - i) The service function “configuration of interfaces” shall be selected.
 - j) It shall be inspected to see whether this selection is possible.
 - k) The result obtained shall be compared to the required test results in paragraph 3 in order to prove compliance with the requirement.

3. Required test result

The following service functions shall not be selectable in navigation mode:

- a) static correction of the chart position
- b) static correction of the chart orientation
- c) configuration of interfaces.

Article 7.17 **Hardware requirement**

1. Reference

This clause refers to Part I, Chapter 2, Article 2.06(1).

2. Test method

- a) For Inland ECDIS in system configuration 4, all components of the Inland ECDIS shall be tested against the requirements of equipment categorized as ‘b) protected from weather’ as specified in REF#IEC-60945, with the exception that the test temperature range is limited from 0 °C to +40 °C (whereas the test temperature range in REF#IEC-60945 is specified from –15 °C to +55 °C).
- b) The manufacturer shall submit a relevant conformity declaration of an accredited laboratory.
- c) The result obtained shall be compared to the required test results in paragraph 3(a) in order to prove compliance with the requirement.
- d) For Inland ECDIS in system configuration 2 and system configuration 3, the manufacturer shall provide a CE Document of Conformity under its own responsibility.

- e) Hardware components used for providing radar information from the radar processor for display on the Inland ECDIS screen shall be tested against the relevant requirements of equipment categorized as 'b) protected from weather' as specified in REF#IEC-60945, with the exception that the test temperature range is limited from 0 °C to +40 °C.
 - f) The result obtained shall be compared to the required test results in paragraph 3(b) in order to prove compliance with the requirement.
 - g) For Inland ECDIS in system configuration 3, monitors shall be tested against the requirements of equipment categorized as 'b) protected from weather' as specified in REF#IEC-60945, with the exception that the test temperature range is limited from 0°C to +40 °C.
 - h) The result obtained shall be compared to the required test results in *paragraph 3(c) in order to prove compliance with the requirement.
3. Required test result
- a) For Inland ECDIS in system configuration 4, all components of the Inland ECDIS installed inside the wheelhouse shall fulfil the requirements of equipment categorized as 'b) protected from weather' as specified in REF#IEC-60945, with the exception that the test temperature range is limited to 0 °C to +40 °C (whereas the test temperature range in REF#IEC-60945 is specified from -15 °C to +55 °C).
 - b) For Inland ECDIS in system configuration 2 and system configuration 3, in general CE conformity is sufficient, but not for hardware components used for providing radar information from the radar processor for display on the Inland ECDIS screen.
 - c) For Inland ECDIS in system configuration 3, the monitor has to fulfil the same requirements as a monitor used in Inland ECDIS in system configuration 4.

Article 7.18 **Display**

1. Reference

This clause refers to Part I, Chapter 2, Article 2.06(2).

2. Test method

This test is already covered by other clauses of this Part.

3. Required test result

This test is already covered by other clauses of this Part.

Article 7.19
Screen dimensions

1. Reference

This clause refers to Part I, Chapter 2, Article 2.06(3).

2. Test method

- a) The test shall be performed in a laboratory.
- b) The Inland ECDIS shall be set to the standard operation setup as defined in Article 4.02(4) of this Part.
- c) The dimensions of the radar display area shall be measured with an appropriate measurement tool (e.g. a ruler).
- d) The result obtained shall be compared to the required test results in paragraph 3 in order to prove compliance with the requirement.
- e) The effective diameter of the visible radar picture on the screen shall be measured with an appropriate measurement tool (e.g. a ruler).
- f) The result obtained shall be compared to the required test results in paragraph 3 in order to prove compliance with the requirement.

3. Required test result

The minimum chart display area on the screen shall be at least 270 mm by 270 mm and the effective diameter of the visible radar picture on the screen shall not be less than 270 mm.

Article 7.20
Screen resolution

1. Reference

This clause refers to Part I, Chapter 2, Article 2.06(4).

2. Test method

- a) The test shall be performed in a laboratory.
- b) The Inland ECDIS shall be set to the standard operation setup as defined in Article 4.02(4) of this Part.
- c) The display resolution of the Inland EDCIS screen shall be checked in the video settings or by other appropriate means.
- d) The result obtained shall be compared to the required test results in paragraph 3 in order to prove compliance with the requirement.

3. Required test result

The display resolution shall be equal to or higher than 1 000 pixels at the short edge of the screen.

Article 7.21
Display and screen brightness

1. Reference

This clause refers to Part I, Chapter 2, Article 2.06(6).

2. Test method

- a) The test shall be performed in a laboratory.
- b) The Inland ECDIS shall be set to the standard operation setup as defined in Article 4.02(4) of this Part.
- c) The radar echo colour shall be set to white colour.
- d) The foreground screen brightness will be adjusted to the lowest adjustable value. Then the luminance of a radar echo as well as of the background shall be determined by a luminance metre.
- e) Following the low brightness test, the ambient room illumination shall be raised to bright daylight levels and the luminance controls suitably adjusted. Several persons of the test team shall then conduct a visual assessment to ensure that the display can be clearly interpreted.
- f) The results obtained shall be compared to the required test results in paragraph 3(a) in order to prove compliance with the requirement.
- g) The chart and radar picture shall be inspected regarding the existence of separate brightness controls.
- h) The results obtained shall be compared to the required test results in paragraph 3(b) in order to prove compliance with the requirement.
- i) Inspection shall take place as to whether the Inland ECDIS has another control for the basic brightness of the display, available in addition to the colour tables in the menu.
- j) The result obtained shall be compared to the required test results in paragraph 3(c) in order to prove compliance with the requirement.

3. Required test result

- a) The brightness of the features and radar echoes on the screen shall not exceed a value of 5 cd/m², and the background shall not exceed a value of 0,1 cd/m².
- b) The chart and radar picture shall have separate brightness controls.
- c) The Inland ECDIS shall have another control for the basic brightness of the display, available in addition to the colour tables in the menu.

Article 7.22
Picture refresh rate

1. Reference

This clause refers to Part I, Chapter 2, Article 2.06(7).

2. Test method
 - a) This test shall be conducted aboard a vessel under way and by inspection of documentation in the laboratory.
 - b) The Inland ECDIS shall be set to the standard operation setup as defined in Article 4.02(5) of this Part.
 - c) The radar picture shall be observed for several revolutions.
 - d) The number of radar pictures per minute shall be measured and compared to the required test results in 3(a) in order to prove compliance with the requirement.
 - e) The brightness of consecutive radar echoes shall be inspected and compared to the required test results in paragraph 3(b) in order to prove compliance with the requirement.
 - f) The manufacturer shall provide a document from the monitor manufacturer that provides information regarding frame repetition rate and switching time.
 - g) The result obtained shall be compared to the required test results in paragraph 3(c) in order to prove compliance with the requirement.
3. Required test result
 - a) The picture refresh rate shall not be shorter than that of the radar picture (≥ 24 pictures per minute).
 - b) Between two consecutive refreshes no fluctuations of brightness shall occur.
 - c) On raster scan monitors, the frame repetition rate shall not be lower than 60 Hz and the switching time shall not exceed 50 ms.

Article 7.23
Connection of other equipment

1. Reference

This clause refers to Part I, Chapter 2, Article 2.07(1).
2. Test method
 - a) The test shall be performed in a laboratory.
 - b) The Inland ECDIS shall be set to the standard operation setup as defined in Article 4.02(4) of this Part.
 - c) The manufacturer shall provide a complete list of optional sensors that can be connected to the Inland ECDIS.
 - d) All sensors shall be connected to the Inland ECDIS. As an alternative, simulated data can be fed into the Inland ECDIS.
 - e) The behaviour of the Inland ECDIS shall be compared to the required test results in paragraph 3(a) in order to prove compliance with the requirement.
 - f) Each interface shall be removed and reconnected to the Inland ECDIS during operation. The results obtained shall be compared to the required test results in paragraph 3(b) in order to prove compliance with the requirement.

3. Required test result
 - a) The Inland ECDIS shall not affect the performance of any connected sensors adversely.
 - b) Similarly, the connection of optional sensors shall not degrade the performance of the Inland ECDIS. Electronic circuits shall be designed failsafe, mechanically as well as electronically, and shall not have degrading repercussions on connected sensors.

Article 7.24
Accuracy of rate of turn indicators

1. Reference

This clause refers to Part I, Chapter 2, Article 2.07(3).

2. Test method

- a) This test shall be conducted aboard a vessel under way.
- b) The Inland ECDIS shall be set to the standard operation setup as defined in Article 4.02(5) of this Part.
- c) The vessel shall navigate a manoeuvre with a constant rate of turn of 10 deg/min, 30 deg/min and 60 deg/min.
- d) Each manoeuvre shall last at least 60 seconds.
- e) An autopilot shall be used to maintain constant turn rates, if available.
- f) The dynamic deviation between the chart orientation and the radar picture shall be confirmed by observation.
- g) The rate of turn, indicated on the vessel's own rate of turn indicator, shall be compared to the rate of turn indicated in the Inland ECDIS.
- h) The result obtained shall be compared to the required test results in paragraph 3(a) and (b) in order to prove compliance with the requirement.

3. Required test result

- a) When the ROT is less than ± 60 deg/min, the dynamic deviation between the chart orientation and the radar picture shall be less than ± 3 degrees.
- b) The deviation between the displayed ROT and the ROT sent by the connected ROT indicator shall be less than ± 3 deg/min.

Article 7.25
Built-in Test Equipment (BITE)

1. Reference

This clause refers to Part I, Chapter 2, Article 2.08(1).

2. Test method

- a) The test shall be performed in a laboratory.
- b) The Inland ECDIS shall be set to the standard operation setup as defined in Article 4.02(4) of this Part.
- c) The built-in self-test function shall be started manually. The items checked shall be noted in the test report.
- d) If the Inland ECDIS provides an automatic self-test function, the manufacturer shall provide further information:
 - i) When does the automatic self-test start?
 - ii) How often does it run?
 - iii) Which event triggers the self-test?
 - iv) Where is the result of the self-test stored?
 - v) Which items are checked?
- e) All this information shall be noted in the test report.
- f) The log file of the automatic self-test shall be inspected.
- g) The results obtained shall be compared to the required test results in paragraph 3 in order to prove compliance with the requirement.

3. Required test result

Inland ECDIS in navigation mode shall be provided with the means for carrying out on-board tests of major functions either automatically or manually. In case of a failure, the module at fault shall be shown.

Article 7.26
Malfunctions

1. Reference

This clause refers to Part I, Chapter 2, Article 2.08(2).

2. Test method

- a) This test shall be conducted aboard a vessel under way.
- b) The Inland ECDIS shall be set to the standard operation setup as defined in Article 4.02(5) of this Part.
- c) The built-in test equipment shall be started.
- d) The results obtained shall be compared to the required test results in paragraph 3(a) in order to prove compliance with the requirement.
- e) The GNSS receiver shall be set as the primary source for position information.
- f) It shall be confirmed by observation if the Inland ECDIS processes this position information (moving chart).
- g) The GNSS receiver shall be configured to stop providing positioning information. The time to alarm shall be measured. The information on the Inland ECDIS display shall be compared to the required test results in paragraph 3(a) to (f) in order to prove compliance with the requirement.

- h) The GNSS receiver shall be configured providing positioning information again.
 - i) The radar shall be disconnected from the Inland ECDIS.
 - j) The result obtained shall be compared to the required test results in paragraph 3(a) in order to prove compliance with the requirement.
 - k) Radar shall be reconnected to the Inland ECDIS.
 - l) The rate of turn device shall be disconnected.
 - m) The result obtained shall be compared to the required test results in paragraph 3(a) in order to prove compliance with the requirement.
 - n) The rate of turn device shall be reconnected to the Inland ECDIS.
 - o) The THD shall be disconnected. The time to alarm shall be measured. The information on the Inland ECDIS display shall be compared to the required test results in paragraph 3(a) to (f) in order to prove compliance with the requirement.
 - p) The THD shall be reconnected to the Inland ECDIS.
 - q) The AIS device shall be disconnected.
 - r) The result obtained shall be compared to the required test results in paragraph 3(a) in order to prove compliance with the requirement.
 - s) The AIS device shall be reconnected to the Inland ECDIS.
 - t) All available non-essential sensors (e.g. wind sensor) shall be connected.
 - u) Each sensor shall be disconnected consecutively.
 - v) The result obtained shall be compared to the required test results in paragraph 3(b) in order to prove compliance with the requirement.
 - w) The requirement of paragraph 3(c) to (f) shall be checked in conjunction with Article 7.08 and Article 7.09 of this Part to prove compliance.
3. Required test result
- a) Inland ECDIS shall send appropriate alarms of malfunction of the essential equipment. The following situations shall at least be covered:
 - i) any error in the Inland ECDIS (built-in test equipment — BITE);
 - ii) missing positioning signal;
 - iii) missing radar signal;
 - iv) missing rate of turn signal;
 - v) missing heading signal;
 - vi) radar map matching not possible;
 - vii) missing AIS signal.
 - b) Inland ECDIS shall send appropriate warnings of malfunction of a non-essential piece of equipment.
 - c) The navigation system shall check proper operation of the position and heading estimation in real-time. Problems shall be detected within 30 seconds. In case of malfunction, the navigation system shall inform the user about the problem and its consequences for navigation.
 - d) If a critical sensor alarm signals that the position or the heading does not meet the required accuracy criteria, the navigation chart shall be switched off.
 - e) The Inland ECDIS shall send an alarm if the input from the position-fixing system is lost.

- f) The Inland ECDIS shall also repeat, but only as a warning, any alarm or other warning passed to it from a position fixing system.

Article 7.27
Insufficient accuracy of the SENC-positioning

1. Reference

This clause refers to Part I, Chapter 2, Article 2.09(1).

2. Test method

- a) This requirement also covers the requirement as stated in Article 7.06(3)(g) of this Part.
- b) This test cannot be performed in full because there is no second system available that reliably calculates the required position and heading accuracy.
- c) As a minimum requirement, in case of a loss of position data or heading data, the SENC shall be switched off. This test is subject to Article 7.26 of this Part (see 7.26(3)(d)).

3. Required test result

- a) The SENC shall be automatically switched off, if the SENC positioning does not match the radar picture within the limits set out in Part I, Chapter 2, Article 2.03(11)(b)(iii) and Article 2.03(13)(a)(i).
- b) If the quality and plausibility monitoring of the Inland ECDIS detect that the chart cannot be oriented and/or positioned with the specified accuracy, an alarm shall be presented on the display and the chart shall be switched off automatically. If there is no radar signal, the information mode shall be displayed, and an alarm shall be given according to Article 7.06(3)(g) of this Part.

Article 7.28
Defects

1. Reference

This clause refers to Part I, Chapter 2, Article 2.09(2).

2. Test method

- a) This test shall be conducted aboard a vessel under way.
- b) The Inland ECDIS shall be set to the standard operation setup as defined in Article 4.02(5) of this Part.
- c) Each of the following devices shall be disconnected:
- i) GNSS receiver
 - ii) radar device
 - iii) rate of turn device
 - iv) heading device
 - v) AIS device.
- d) The behaviour of Inland ECDIS shall be confirmed by observation and the result obtained shall be compared to the required test results in paragraph 3(a) and (b).

- e) The device shall be reconnected to the Inland ECDIS.
 - f) The behaviour of Inland ECDIS shall be confirmed by observation and the result obtained shall be compared to the required test results in paragraph 3(a) and (b).
3. Required test result
- a) If Inland ECDIS has a defect, it shall send a suitable alarm at least for the following parameters:
 - i) any error in the Inland ECDIS (built-in test equipment — BITE);
 - ii) missing positioning signal;
 - iii) missing radar signal;
 - iv) missing rate of turn signal;
 - v) missing heading signal;
 - vi) radar image and map impossible to superimpose properly;
 - vii) missing AIS signal.
 - b) If there is no radar signal, the information mode shall be displayed (according to Article 7.06 of this Part).

Article 7.29 ***Endurance test***

1. Reference

This clause refers to Part I, Chapter 2, Article 2.10(1).

2. Test method

- a) The test shall be performed in a laboratory.
- b) The Inland ECDIS shall be set to the standard operation setup as defined in Article 4.02(4) of this Part.
- c) The Inland ECDIS shall be run for at least 48 hours under normal operation conditions. Any interruption shall be noted in the test report and shall cause a restart of the test period. The performance and the resource consumption shall be monitored continually and recorded on a file. In particular, system stability, memory leaking and any kind of performance loss over time shall be monitored.
- d) The result obtained shall be compared to the required test results in paragraph 3 in order to prove compliance with the requirement.

3. Required test result

The Inland ECDIS shall run for at least 48 hours of uninterrupted operation under normal operation conditions. The system shall provide standard interfaces for performance and resource monitoring during operation. Monitoring the system shall show no indication of system instability, memory leaking or any kind of performance loss over time. The Inland ECDIS that is supporting additional services shall provide the necessary test equipment.

Article 7.30
Documentation

1. Reference

This clause refers to Part I, Chapter 2, Article 2.10(2).

2. Test method

- a) The test shall be performed in a laboratory.
- b) The manufacturer shall provide the documents as required by paragraph (3)(a) of this Part.
- c) Each document shall be checked against requirements of Part I and common rules (safety instructions etc.).
- d) The result obtained shall be compared to the required test results in paragraph 3(b) in order to prove compliance with the requirement.

3. Required test result

- a) The following documents shall be provided for admittance:
 - i) user's manual
 - ii) installation manual
 - iii) service manual
 - iv) design specification.
- b) The documents and files provided shall allow for a complete verification of compliance with the Inland ECDIS technical specifications.

CHAPTER 8

TEST DESCRIPTIONS

Article 8.01

Test charts and test scenarios

The following IENCs are necessary to complete the clauses of this Part.

No.	Ref.	Content	Note
00	5.05	Test IENC that comprises all symbols out of the Inland ECDIS symbol library and a selection of representative line and area features	WGS-84 coordinates of the centre of the IENC shall be provided with the chart.
01	5.01 5.13 5.14 6.01 6.02	Test IENC that comprises the following objects: <ul style="list-style-type: none"> a) bank of waterway (at mean water level), b) construction (e.g. groin, longitudinal control dam, training wall – any facility that is considered a hazard to navigation), c) contours of locks and dams, d) boundaries of the fairway/navigation channel (if defined), e) isolated dangers in the fairway/navigation channel under water, f) isolated dangers in the fairway/navigation channel above water level, such as bridges, overhead cables etc., g) official Sign and Marking information (AtoN “aids-to-navigation”) aids-to-navigation (e.g. buoys, beacons, lights, notice marks), h) waterway axis with kilometres indication where it is defined, i) location of ports and transshipment sites, j) reference data for water level gauges relevant to navigation, k) links to the external xml-files with operation times of restricting structures, in particular locks and bridges. 	WGS-84 coordinates of the centre of the IENC shall be provided with the chart.
02	5.02 7.01	Test IENC that comprises at least two IENC cells.	WGS-84 coordinates shall be provided such that both IENC cells can be displayed simultaneously.
02-01	5.02	Incremental update test file referring to IENC cell of chart 02	
02-02	5.02	Incremental update test file not referring to any of the IENC cells of chart 02	

No.	Ref.	Content	Note
02-03	5.02	Incremental update with more than one incremental update test file, referring to all IENC cells of chart 02	
03	5.04	Test IENC that comprises depth information and water level model	WGS-84 coordinates of the centre of the IENC shall be provided with the chart.
04	5.05	Test IENC that comprises all symbols out of the Inland ECDIS symbol library, a selection of representative line and area features and all additional symbols provided by the manufacturer.	Shall be provided by manufacturer; WGS-84 coordinates of the centre of the IENC shall be provided with the chart.
05	5.06	A test IENC that comprises a bridge across a waterway	WGS-84 coordinates of the centre of the IENC shall be provided with the chart.
06a 06b	5.07	Two adjacent test IENCs that both comprise parts of the same feature (e.g. a bridge, that is included half in one cell and half in the other IENC cell). That feature shall be correctly encoded. Both parts shall have references to each other.	WGS-84 coordinates of the centre of the IENC shall be provided with the chart.
07	5.08 5.09 5.14 5.20	A test IENC with "open water" and no land mass and other features.	WGS-84 coordinates of the centre of the IENC shall be provided with the chart.
08	5.12	A test IENC that comprises at least ten different features from different feature classes.	WGS-84 coordinates of the centre of the IENC shall be provided with the chart.
09	5.10	An IENC that comprises one AtoN object with a MMSI ("physical AIS AtoN" or "synthetic AIS AtoN") and one AtoN object without a MMSI ("conventional AtoN" without AIS). OBJ1 and OBJ2 shall be placed out-of the centre of the chart.	WGS-84 coordinates of both objects and the centre of the chart shall be provided with the chart. The MMSI of the IENC feature shall also be provided with the chart.

No.	Ref.	Content	Note
10	5.10	An IENC with no content.	WGS-84 coordinates of the center of the chart shall be provided with the chart.

The following real life scenarios are necessary to complete the clauses of this Part.

No	Ref.	Content	Note
01	5.10 5.11 5.15 5.17 5.18 5.19 5.21	A recorded test data file comprising an IENC with overlaid radar and ROT information	Shall be provided by manufacturer

Article 8.02 **AIS protocol simulator**

1. An appropriate PC-software shall be used to simulate AIS - VDM (AIS VHF data-link message) and VDO (AIS VHF data-link own-vessel report) messages according to REF#ITU-R1371. This AIS protocol simulator shall also support Inland AIS messages. It shall be possible to configure the location of the vessel (coordinate) as well as to define a track (several coordinate-pairs). The reporting rate shall be configurable from 3 seconds up to 10 minutes. It shall be possible to create messages from Inland AIS, AIS class A, AIS class B, AIS base station, AIS SAR and AIS SAR devices. It shall be possible to create a "loss of VHF antenna" message and it shall be possible to configure the following parameters:
 - a) AIS device identity (MMSI);
 - b) vessel name;
 - c) VHF radio call sign of the vessel;
 - d) vessel or convoy type;
 - e) unique European vessel Identification Number (ENI) or, for seagoing vessels that have not been given an ENI number, the IMO number;
 - f) length overall of the vessel or convoy accurate to 0.1 m;
 - g) breadth overall of the vessel or convoy accurate to 0.1 m;
 - h) reference point for the positional information aboard the vessel, accurate to 1 m (this is the position of the GPS antenna of the Inland AIS device);
 - i) position of the vessel (derived from GPS in WGS 84 coordinate system);
 - j) time indication of position determination by the electronic position location device;

- k) speed over ground;
 - l) course over ground;
 - m) navigational status;
 - n) cones;
 - o) blue sign.
2. It shall be possible to configure the position accuracy flag ("PA flag").

Article 8.03
GNSS protocol simulator

1. An appropriate PC-software shall be used to simulate GNSS data sentences according to REF#EN-61162-2.
2. It shall be possible to create, at least, the following data sentences:
- a) Time, position, and fix related data (GGA – "\$--GGA");
 - b) GNSS satellite fault detection (GBS – "\$--GBS");
 - c) GPS DOP and active satellites (GSA – "\$--GSA").
3. Any of the fields of these data sentences shall be configurable.
4. It shall be possible to configure the location of the vessel (coordinates) as well as to define a track (several coordinate-pairs).
5. The reporting rate shall be configurable from 1 second up to 60 seconds.

Article 8.04
Heading protocol simulator

1. An appropriate PC-software shall be used to simulate heading data sentences according to REF#EN-61162-2.
2. It shall be possible to create, at least, the following data sentences:
- Heading from True North (HDT - "\$--HDT).
3. Any of the fields of this data sentence shall be configurable.
4. It shall be possible to configure the current heading value of the vessel as well as to define consecutive heading values to simulate a turning manoeuvre.
5. The reporting rate shall be configurable from 1 second up to 60 seconds.

Article 8.05
Additional sensor protocol simulator

1. An appropriate PC-software shall be used to simulate additional sensor data sentences according to REF#EN-61162-2.
2. Any of the fields of this data sentence shall be configurable.
3. This sensor protocol simulator shall be provided by the manufacturer.

Article 8.06
AIS protocol manipulator

1. An appropriate PC-software shall be used to manipulate AIS VDM and VDO data sentences in real time and according to REF#EN-61162-2 and REF#ITU-R1371.
2. It shall be possible to set any of the fields of these data sentences to a configurable value in real time.
3. It shall be possible to add a position offset (e.g. 5 metres) to the real position in real time.
4. It shall be possible to alter the field "PA flag" to any permitted value in real time.

Article 8.07
GNSS protocol manipulator

1. An appropriate PC-software shall be used to manipulate data sentences in real time and according to REF#EN-61162-2.
2. It shall be possible to manipulate at least the following data sentences:
 - a) Time, position, and fix related data (GGA – "\$--GGA");
 - b) GNSS satellite fault detection (GBS – "\$--GBS");
 - c) GPS DOP and active satellites (GSA – "\$--GSA").
3. It shall be possible to set any of the fields of these data sentences to a configurable value in real time.
4. It shall be possible to add a position offset (e.g. 5 metres) to the real position in real time.
5. It shall be possible to add a simulated sentence to the output although the sentence has not been received from GNSS receiver.

Article 8.08
Heading protocol manipulator

1. An appropriate PC-software shall be used to manipulate data sentences in real time and according to REF#EN-61162-2.
2. It shall be possible to manipulate at least the following data sentence:
Heading from True North (HDT - \$--HDT).
3. It shall be possible to set any of the fields of these data sentences to a configurable value in real time.
4. It shall be possible to add a heading offset (e.g. 0,5°) to the real heading in real time.

Article 8.09
AtoN protocol simulator

1. An appropriate PC-software shall be used to generate AIS-VDM messages of type 21 according to REF#EN-61162-1 and REF#ITU-R1371 and provide this information on an interface (Presentation interface sentence or "PI-sentence").
2. All the following fields shall be configurable on the simulator:
 - a) Message ID (always 21),
 - b) Repeat Indicator,
 - c) ID,
 - d) AtoN type,
 - e) AtoN name,
 - f) Position accuracy,
 - g) Longitude,
 - h) Latitude,
 - i) dist A,
 - j) dist B,
 - k) dist C,
 - l) dist D,
 - m) EPFD,
 - n) time stamp,
 - o) off Position Indicator,
 - p) AtoN Status,
 - q) RAIM flag,
 - r) Virtual flag,
 - s) Assigned mode flag,
 - t) extended name.

CHAPTER 9

RELATIONSHIP BETWEEN REQUIREMENTS AND CLAUSES

Table V-1 shows the relationship between the requirements of Part I to the corresponding clause of this Part.

Table V-1
Relationship between requirements and clauses

Legend: L = Laboratory, V = Vessel

Requirement of Part I, Chapter 2	Clause of this Part		Mode	Location of the test
Article 2.01(1)	5.01	Content of IENC	all	L
Article 2.02(1)	5.02	Updates	all	L
	7.01	Updates	navigation	L
Article 2.03(1)	7.02	Image positioning and orientation	navigation	V
Article 2.03(2)	5.03	Screen orientation, chart orientation, positioning and shifting	all	L
	7.03	Screen orientation, chart orientation, positioning and shifting	navigation	V
Article 2.03(3)	7.04	Position and heading of the own vessel	navigation	V
Article 2.03(4)	5.04	Display of SENC information	all	L
	7.05	Display of SENC information	navigation	V
Article 2.03(5)	5.05	Colours and symbols	all	L
Article 2.03(6)	5.06	Scale dependent information density (SCAMIN)	all	L
Article 2.03(7)	5.07	Features displayed in several cells with the same use for the same area	all	L
Article 2.03(8)	7.06	Display of radar information	navigation	V
Article 2.03(9)	5.08	Display of tracking and tracing information	all	L
Article 2.03(10)	-	-	-	-
Article 2.03(11)	7.07	Data and display accuracy	navigation	L
Article 2.03(12)	7.08	Position accuracy	navigation	L

Requirement of Part I, Chapter 2	Clause of this Part		Mode	Location of the test
Article 2.03(13)	7.09	Heading accuracy	navigation	L
Article 2.03(14)	5.09	Display of AIS targets of other vessels	all	L
Article 2.03(15)	5.10	Display of AIS Aids to Navigation	all	L
Article 2.03(16)	not yet available	Display of AIS Application Specific Messages	all	not yet available
Article 2.04(1)	5.11	Operation	all	L
	6.01	Operation	information	L
	7.10	Operation	navigation	V
Article 2.04(2)	5.12	Ergonomics of control elements	all	L
	7.11	Ergonomics of control elements	navigation	L
Article 2.04(3)	5.13	Characteristics of control elements	all	L
Article 2.04(4)	5.14	Pick report	all	L
Article 2.04(5)	5.15	Measuring features	all	L
Article 2.04(6)	5.16	Input and editing of boatmasters' own chart entries	all	L
	7.12	Input and editing of boatmasters' own chart entries	navigation	L
Article 2.04(7)	7.13	Scales, Ranges/Range rings	navigation	V
Article 2.04(8)	7.14	Inland ECDIS pre-sets (store/recall) in navigation mode	navigation	L
Article 2.04(9)	5.17	Control elements	all	L
	7.15	Control elements	navigation	V
Article 2.04(10)	5.18	Operation of AIS targets of other vessels	all	L
Article 2.04(11)	-	Operation of AIS Aids to Navigation	-	-
Article 2.04(12)	not yet available	Operation of AIS Application Specific Messages	all	not yet available

Requirement of Part I, Chapter 2	Clause of this Part		Mode	Location of the test
Article 2.05(1)	5.19	Service functions	all	L
	7.16	Service functions	navigation	L
Article 2.06(1)	7.17	Hardware requirement	navigation	L
Article 2.06(2)	5.20	Display	all	L
	7.18	Display	navigation	-
Article 2.06(3)	6.02	Screen dimensions	information	L
	7.19	Screen dimensions	navigation	L
Article 2.06(4)	6.03	Screen resolution	information	-
	7.20	Screen resolution	navigation	L
Article 2.06(5)	5.21	Display colours	all	L
Article 2.06(6)	5.22	Display and screen brightness	all	L
	7.21	Display and screen brightness	navigation	L
Article 2.06(7)	7.22	Picture refresh rate	navigation	V
		Picture refresh rate	navigation	L
Article 2.07(1)	5.23	Connection of other equipment	all	L
	7.23	Connection of other equipment	navigation	L
Article 2.07(2)	5.24	Configuration of interfaces	all	L
Article 2.07(3)	7.24	Accuracy of rate of turn indicators	navigation	V
Article 2.08(1)	7.25	Built-in Test Equipment (BITE)	navigation	L
Article 2.08(2)	6.04	Malfunctions	information	L
	7.26	Malfunctions	navigation	V
Article 2.09(1)	7.27	Insufficient accuracy of the SENC-positioning	navigation	V
Article 2.09(2)	7.28	Defects	navigation	V
Article 2.10(1)	7.29	Endurance test	navigation	L

Requirement of Part I, Chapter 2	Clause of this Part		Mode	Location of the test
Article 2.10(2)	5.25	Documentation	all	L
	6.05	Documentation	information	L
	7.30	Documentation	navigation	L
Article 2.10(3)	5.26	Interfaces	all	L
	6.06	Interfaces	information	L

PART VI
INLAND AIS EQUIPMENT OPERATIONAL AND PERFORMANCE
REQUIREMENTS, METHODS OF TEST AND REQUIRED TEST
RESULTS
(TEST PART OF INLAND AIS)

CHAPTER 1
SCOPE

This Part specifies the minimum operational and performance requirements, methods of testing and required test results for Inland AIS stations, i.e. Inland AIS mobile station and Inland AIS AtoN station.

This edition incorporates for Inland AIS mobile station the technical characteristics of Class A shipborne equipment included in REF#ITU-R1371 and further described by REF#IEC 61993-2 as applicable.

This edition incorporates for Inland AIS AtoN station the technical characteristics of (maritime) AIS AtoN station equipment included in REF#ITU-R1371 and further described by REF#IEC-62320-2 as applicable.

CHAPTER 2

NORMATIVE REFERENCES

References are given in Part 0, Chapter 3.

CHAPTER 3 ***ABBREVIATIONS***

Abbreviations are given in Part 0, Chapter 1.

CHAPTER 4

SHIPBORNE INLAND AIS STATIONS- GENERAL REQUIREMENTS

Shipborne Inland AIS stations are based on the specification of AIS Class A shipborne equipment in accordance with REF#ITU-R1371 and REF#IEC-61993-2 unless otherwise stated.

Article 4.01

Class A functions not required

Shipborne Inland AIS stations have to fulfil all requirements of AIS Class A shipborne equipment as defined in REF#IEC-61993-2 except:

1. Long range application by interface to other equipment,
2. Interface for long range port.

Article 4.02

Functions in addition to Class A

Additionally the following functions are required:

1. Initiate and transmit inland specific messages as specified in Table VI-2;
2. Process and display received inland specific messages as specified in Table VI-3;
3. Act upon group assignment for station type "inland waterways";
4. Interface to receive and process differential correction data (REF#RTCM-DGNSS);
5. Interface for Blue Sign function (switch and use of data field in VSD sentence);
6. Suppress the transmission of certain ABM/BBM sentences from PI port as specified in Table VI-2;
7. Inland specific message RFM 10 shall be transmitted with a reporting interval of 6 minutes, alternating between both channels, following message 5;
8. All speed information shall be displayed in km/h on MKD and all range information shall be displayed in km.

Article 4.03

Manuals

The manuals shall also cover the methods necessary to support the Inland AIS specific function.

CHAPTER 5
***SHIPBORNE INLAND AIS STATIONS - ENVIRONMENTAL, POWER SUPPLY,
SPECIAL PURPOSE AND SAFETY REQUIREMENTS***

The same requirements as for AIS Class A mobile station shall be fulfilled.

CHAPTER 6

SHIPBORNE INLAND AIS STATIONS- PERFORMANCE REQUIREMENTS

Article 6.01

Composition

An interface (REF#RTCM-DGNSS) shall be provided to input the correction data to the internal GNSS receiver.

The Inland AIS station shall be able to process Group Assignment Commands (AIS message 23) for station type “inland waterways” and act accordingly.

The Inland AIS station shall be able to process the Blue Sign information and set the special manoeuvre indicator in AIS VDL Message 1, 2, 3 accordingly.

The Inland AIS station shall be able to process Inland specific Regional Function messages (RFM) with the Designated Area Code (DAC) “200”¹

1. Blue Sign input

The Blue Sign information shall be input in two ways:

a) Blue Sign input via the REF#IEC-61162-1 VSD sentence

The VSD field “regional application flags” defines 4 bit (values 0...15). The two most significant bits of the regional application flags set the “Special manoeuvre indicator” parameter. The remaining two bits of the VSD sentence shall be ignored.

The following Table describes the translation from the VSD field “regional application flags” to the VDL Message 1, 2, 3 “Special manoeuvre indicator” parameter.

Table VI-1
Translation from VSD sentence to VDL message

VSD sentence regional application flag	VDL Message 1,2,3 Special manoeuvre indicator	Blue Sign description
0 (00xx)	0 (00)	Not available (default)
4 (01xx)	1 (01)	Not set
8 (10xx)	2 (10)	Set
12 (11xx)	0 (00)	Invalid input, results in not available

¹ Unless otherwise stated “RFM” in this document refers to Inland specific Regional Function Messages (RFM) as defined in REF#ITU-R1371 with an Application identifier (AI) consisting of DAC = 200 and the defined Function Identifier (FI) (e.g.: RFM 10 = DAC “200” + FI “10”).

The special manoeuvre indicator (Blue Sign) parameter shall only be set if the VSD sentence is received with a valid regional application flag value and an interval of at least two seconds. After a time out of two seconds the special manoeuvre indicator shall be set to not available.

b) Blue Sign status via a dedicated input port

The input for the Blue Sign status shall preferably provide a tri-state or alternatively a two-state input which can be controlled by a single switch where the switch circuit open means "Blue Sign not set" and the switch circuit closed means "Blue Sign set".

The presence of the direct connected switch shall be made available by automatic means or manual configuration.

2. Internal GNSS receiver

The Inland AIS station shall provide an internal GNSS receiver as UTC source, for own positioning, COG and SOG. The internal GNSS receiver shall meet the appropriate requirements of the International Standards series IEC 61108 as defined in REF#IEC-61993-2. The internal GNSS receiver shall be capable of processing differential correction data from a dedicated REF#RTCM-DGNSS interface and via VDL Message 17.

Article 6.02 **Information**

Information provided by the Inland AIS shall be as defined in Vessel Tracking and Tracing Standard for Inland Navigation as stated in Chapter 2 "Normative reference" (ES-TRIN, Article 1.01(7.9)).

The static, dynamic and voyage related ship information for inland vessels shall have the same parameters and the same structure than in REF#ITU-R1371 as far as it is applicable. Not used parameter fields shall be set to "not available". Inland specific static ship information shall be added.

Article 6.03 **Information processing**

1. Inland AIS Data input

The Figure 14-1 in Annex 14 illustrates the parameters and the usage to calculate the dimensions for both message 5 and RFM 10.

- a) All dimensions/reference input values of own ship shall be input in decimetre resolution.
- b) The total convoy length LC and convoy beam BC are calculated in dm and shall be transmitted by RFM 10.
- c) Draught: input always in cm, automatic conversion to next higher value (rounding up) for message 5.
- d) The ship and cargo type of message 5 shall be automatically converted from Inland-ship type (Inland vessel and convoy types; see Annex 10).
- e) IMO ship and cargo type can be overwritten according to the Class A rules.

- f) The number of blue cones can be entered independently of IMO ship and cargo type.
- g) For backwards compatibility the PI sentences IWWIVD and IWWSSD shall be maintained for dimensions/reference input for inland navigation mode.

2. Inland AIS Data storage and message compilation

For data input of the required information for transmission either means for manual input or the proposed digital interface sentences for Inland AIS (\$--SSD, \$--VSD, \$PIWWSSD and \$PIWWIVD) shall be used. This requires means for input and storage of the inland specific data. Only inputs that change the stored data (manual input or \$--SSD, \$--VSD, \$PIWWSSD, \$--EPV, \$PIWWIVD) shall generate a transmission where applicable.

The following tables define the behaviour of the Inland AIS mobile station regarding inland specific functional messages.

a) Initiation of an inland specific functional message

The following table defines the initiator of international function messages (IFM) and inland specific functional messages (RFM) to be transmitted by the Inland AIS mobile station.

(ABM/BBM = via standard Presentation Interface, MKD = via Minimum Keyboard and Display, Inland ECDIS = via connected Inland ECDIS (recommendation only). On VDL request = autonomous reaction when an IFM 2 or 3 interrogation is received).

Table VI-2
Transmission of inland specific functional messages

Message	Description	Addr/ Bc	TX INITIATED BY			
			ABM/BBM	MKD	Auto-matically generated	On VDL request
RFM 10	Inland static data ¹⁾	Bc	No	---	x	Opt ¹⁾²⁾
RFM 55	Inland number of persons ²⁾	Addr	x	Opt	No	x
RFM 55	Inland number of persons	Bc	x	x	No	No
IFM 4 a)	Capability response ²⁾	Addr	x	---	No	x

'X' = required; 'Opt' = Optional; 'No' = Not allowed; '---' = Not applicable

¹⁾ Autonomously provided in conjunction with AIS VDL message 5 by the Inland AIS mobile station.

²⁾ Message is provided only if interrogation is addressed to own station.

b) Processing of received inland specific functional messages

The following table defines the behaviour (internal processing and reaction) of the Inland AIS mobile station, when an international function message (IFM) or an inland specific functional message (RFM) is received.

(VDM = output via Presentation Interface, MKD = displayed on Minimum Keyboard and Display, Inland ECDIS = displayed on connected Inland ECDIS (recommendation only), VDL response = autonomous reaction on a received VDL message).

Table VI-3
Reception of inland specific functional messages

Message	Description	Addr/Bc	Processing		
			VDM	MKD	VDL Response
RFM 10	Inland static data	Bc	x	X	---
RFM 55	Inland number of persons ¹⁾	Addr	x	X ²⁾	---
RFM 55	Inland number of persons	Bc	x	X ²⁾	---
IFM 2	Interrogation ^{3) 1)}	Addr	x	---	x
IFM 3	Capability interrogation ^{3) 1)}	Addr	x	---	x
IFM 16	Number of persons ¹⁾	Addr	x	X	---
IFM 16	Number of persons	Bc	x	X	---

'X' = required; 'Opt' = Optional; 'No' = Not allowed; '---' = Not applicable

¹⁾ Messages are processed only if addressed to own station.

²⁾ Only the display of total number of persons on board is required.

³⁾ Messages are provided only if interrogation is addressed to own station.

c) Inland specific RFM 10 (Inland ship static and voyage related data) and Inland specific RFM 55 (Persons on board)

The compilation of the RFM 10 and RFM 55 for transmission is part of the Inland AIS station itself:

- i) The RFM 10 shall be used by Inland AIS only, to broadcast ship static and voyage related data in addition to message 5. The message shall be sent not later than 4 seconds after message 5 by using a message 8 / RFM 10;
- ii) Message 5 and RFM 10 shall be transmitted with a reporting interval of 6 minutes, alternating between both channels;
- iii) The Inland AIS station must be able to respond to an interrogation for VDL message 5 (received message 15) automatically with message 5 and message 8 / RFM 10;
- iv) The Inland AIS station must be able to initiate a message 8 / RFM 55 by MKD and to respond on a request for "Inland number of persons on board" automatically with the message 6 / RFM 55.

- d) Inland specific RFM's other than RFM 10 or RFM 55
- The following option is available for the compilation of inland specific messages other than RFM 10 or 55.
- The compilation of inland specific message shall be provided by an external application outside the Inland AIS shipborne station and is input via the Presentation Interface using REF#IEC-61162-1 ABM or BBM sentences as applicable. External applications could be:
- i) a connected Inland ECDIS equipment or Radar equipment,
 - ii) a connected dedicated software application (without Inland ECDIS capability).

3. Alarms and status information

Means shall be provided to selectively disable alarms during installation which are not applicable for that specific installation, i.e. external EPFS lost (25), heading lost/invalid (32), no valid ROT information (35). This feature has to be password protected.

Article 6.04
Minimum Keyboard and Display (MKD)

1. Display of received Messages

In addition to AIS Class A following information shall be displayed on a MKD:

- a) Inland AIS static data
Where information is delivered both by message 5 and RFM 10 the Inland AIS specific date shall preferably be displayed (dimension, draught, ship type, dangerous cargo category).
- b) Number of persons on board
RFM 55 shall have preference above IFM 16
- c) Blue sign information
- d) Speed information shall be displayed in km/h
- e) Range information shall be displayed in km.

Table VI-4
Following information in RFM 10 shall be displayed:

Parameter	Displayed on MKD
ENI	Yes
Length of ship or convoy	Yes
Beam of ship or convoy	Yes
Inland vessel and convoy type	Yes
Number of blue cones	Yes
Draught	Yes
Loaded/unloaded	Yes
Quality of speed information	Optional
Quality of course information	Optional
Quality of heading information	Optional

2. Input of Data

In addition to AIS Class A following data shall be entered via MKD:

a) Inland AIS static data

Where information is contained in both message 5 and RFM 10 the Inland AIS specific data shall input only once to avoid conflicts, i.e. dimension/reference, draught, ship type, dangerous cargo category.

b) Number of persons on board

RFM 55 shall have preference above IFM 16.

Table VI-5
Following information in RFM 10 and RFM 55 shall be input via MKD:

Parameter	Category	Remark
ENI	Static	¹⁾
Length of ship (LS)	Static	¹⁾ Shall also be used for the calculation of message 5 and RFM 10
Distance from reference point to stern (BI) (for internal and external position source)	Static	¹⁾ Shall also be used for the calculation of message 5 and RFM 10
Beam of ship (BS)	Static	¹⁾ Shall also be used for the calculation of message 5 and RFM 10
Distance from reference point to port (CI) (for internal and external position source)	Static	¹⁾ Shall also be used for the calculation of message 5 and RFM 10
Extension for length of convoy (EA, EB)	Voyage related	²⁾ Shall also be used for the calculation of message 5 and RFM 10
Extension for beam of convoy (EC, ED)	Voyage related	²⁾ Shall also be used for the calculation of message 5 and RFM 10

Parameter	Category	Remark
Inland vessel and convoy type	Voyage related	2)
Number of blue cones	Voyage related	2)
Draught	Voyage related	2)
Loaded/unloaded	Voyage related	2)
Persons on board (crew members, passengers and shipboard personnel)	Voyage related	2)
Quality of speed information	Static	On installation, shall be set to 0 if not derived from a type approved sensor
Quality of course information	Static	On installation, shall be set to 0 if not derived from a type approved sensor
Quality of heading information	static	On installation, shall be set to 0 if not derived from a type approved sensor

1) On installation, data shall be protected by the administrator password.

2) Voyage related, data shall not be protected by the administrator password.

3. Initiation of transmission of RFM 55 via MKD

Means on the MKD shall be provided to initiate the transmission of broadcast RFM 55.

CHAPTER 7

SHIPBORNE INLAND AIS STATIONS - TECHNICAL REQUIREMENTS

Article 7.01

Response to Assignment Commands

An Inland AIS station shall process assignment commands in accordance with REF#ITU-R1371 and ES-RIS, Part II. The Inland AIS mobile station shall act upon group assignment for station type "inland waterway" and not for station type "Class A mobile station".

An assignment command, with a reporting interval less than the autonomous reporting interval, received via the digital interface sentence for Inland AIS \$PIWWIVD shall decrease the reporting interval defined by REF#ITU-R1371. An assignment command shall not increase the reporting interval above the autonomous reporting interval.

Article 7.02

Presentation interface

1. Required ports

The Presentation Interface of the Inland AIS shall comprise the data ports listed in Table VI-6 (also see Annex 12).

Table VI-6
Presentation Interface Access

General Function	Mechanism
Automatic Input of Sensor Data (Sensor data input from shipboard equipment)	(3) REF#IEC-61162-2 input ports, also configurable as REF#IEC-61162-1 input ports
High Speed Input / Output Ports (Operator controlled commands and data input; AIS VHF Data Link (VDL) data; and AIS equipment status)	(2) REF#IEC-61162-2 paired input and output ports
BITT Alarm Output	(1) Isolated normally-closed (NC) contact circuit

Note: Pilot port is not required

2. Input data and formats

The Inland AIS shall as a minimum be able to receive and process the input data shown in Table VI-7. The details of these sentences are contained in REF#IEC-61162-1. Manufacturer's proprietary data may also be entered using these high-speed ports.

Table VI-7
AIS High-speed input data and formats

Data	REF#IEC-61162-1 Sentences
Normal Access - Parameter Entry	
<u>Voyage information:</u> Vessel type and cargo category Navigational status Draught, max. actual static Destination ETA date and time Regional application flags Reporting rate settings Number of blue cones air draught of ship Number of assisting tugboat Number of crew members on board Number of passengers on board Number of shipboard personnel on board Convoy extensions	VSD - Voyage static data EPV – Equipment property value PIWWIVD – Inland Waterway voyage data
<u>Station information:</u> Vessel name (administrator password protected) Call sign (administrator password protected) Antenna location length and beam ENI number (administrator password protected) Inland vessel and convoy type Quality of speed information Quality of course information Quality of heading information	SSD - Station static data PIWWSSD – Inland Waterway static ship data
Initiate VHF Data-link Broadcasts	
Safety messages	ABM - Addressed Binary Message BBM - Broadcast Binary Message
Binary messages	ABM - Addressed Binary Message BBM - Broadcast Binary Message
Interrogation Message	AIR - AIS Interrogation Information
AIS Equipment - Parameter Entry	
AIS VHF channel selection AIS VHF power setting AIS VHF channel bandwidth Transmit/Receive mode control MMSI IMO number Other AIS equipment controls	ACA - AIS Channel Assignment Message EPV-Equipment property value (administrator password protected) EPV-Equipment property value (administrator password protected) EPV-Equipment property value (administrator password protected)
BIIT Input	
Alarm / indication acknowledgement	ACK Acknowledgement message

Note: Information which is not marked with “administrator password protected” shall be accepted if no administrator password is provided even if there is protected information in the same sentence. In this case the protected information is ignored.

3. Output data and formats

In addition to the AIS Class A station, an Inland AIS station outputs PIWWSSD and PIWWIVD sentences on the two high speed ports as response on a query.

Query sentences is used as defined in REF#IEC-61162-1 with sentence formatters SSD and IVD. On query for SSD the unit will respond with both an SSD sentence and a PIWWSSD sentence.

CHAPTER 8

SHIPBORNE INLAND AIS STATIONS - OPERATIONAL TESTS

Article 8.01

Operating modes/capability

1. Interrogation response
 - a) Method of measurement

Set up standard test environment and operate EUT in autonomous mode. Apply an interrogation message (message 15; EUT as destination) to the VDL for responses with message 3, message 5 and slot offset set to defined value. Record transmitted messages and frame structure.
 - b) Required results

Check that the EUT transmits the appropriate interrogation response message as requested after defined slot offset. Confirm that the EUT transmits the response on the same channel as where interrogation was received. Confirm that the EUT transmits message 5 and “Inland ship static and voyage related data” RFM 10 using binary broadcast message (message 8) to the VDL. Confirm that the “Inland ship static and voyage related data” RFM 10 follows message 5 within 4 seconds. Confirm that ITDMA is used if possible.

Article 8.02

Reporting intervals

1. Static data reporting rates
 - a) Method of measurement

Set up standard test environment and operate EUT in autonomous mode.

 - i) Record the transmitted messages and check for static and voyage related data (message 5 and RFM 10).
 - ii) Change static and/or voyage related station data. Record the transmitted messages and check for static and voyage related data (message 5).
 - b) Required results
 - i) Confirm that the EUT transmits message 5 with a reporting interval of 6 minutes and the inland specific RFM 10 not later than 4 seconds after message 5 on the same channel using ITDMA if possible. The ITDMA access scheme shall replace a scheduled position report message 1 with a message 3.
 - ii) Confirm that the EUT transmits message 5 and RFM 10 within 1 minute reverting to a reporting interval of 6 minutes.

Article 8.03
Alarms and indicators, fall-back arrangements

1. Method of measurement
Disable the alarms according to Part III, Article 6.03(3).
2. Required results
Confirm that the alarms can be disabled. Confirm that the disabling of alarms is administration password protected.

Article 8.04
Input of Data on MKD

1. Method of measurement
Input all static and voyage related data according to 0 Table VI-5.
2. Required results
Confirm that all data according to 0 Table VI-5 can be input with the appropriate accuracy.
Confirm that the input of data is protected by password according to 0 Table VI-5.
Confirm that the ship and cargo type of message 5 is automatically converted from Inland ship type (Inland vessel and convoy types; see Annex 10) when the Inland vessel and convoy types is input.
Confirm that the IMO ship and cargo type can be overwritten according to the Class A rules.

Article 8.05
Display of Data on MKD

1. Method of measurement
Apply a message 1, 9, 18, 19 to the VDL.
2. Required results
Confirm that the speed is displayed in km/h and the range is displayed in km.

CHAPTER 9

SHIPBORNE INLAND AIS STATIONS - SPECIFIC TESTS OF LINK LAYER

Article 9.01

Group assignment

1. Assignment by \$PIWWIVD

Group assignment commands have precedence of assignments by input via \$PIWWIVD.

a) Method of measurement

Address the EUT with an AIS message 23 to bring the EUT in assigned mode. Record VDL and verify the reaction of the EUT. Apply an assignment by \$PIWWIVD input with a different reporting interval.

b) Required results

Verify that the EUT ignores the assignment by input via \$PIWWIVD.

2. Assignment by message 16

Messages which are addressed directly to an AIS Transponder have precedence of group assignment commands and manual assignments. Following test shall verify the assignment priority of these messages.

a) Method of measurement

Set up the standard test environment and operate EUT in autonomous mode. Input sensor data to achieve a reporting interval of 10 seconds.

i) Address the EUT with an AIS message 16 to bring the EUT in assigned mode with a reporting interval of 5 seconds. Record VDL and verify the reaction of the EUT.

ii) Apply a message 23 with a reporting interval of 2 seconds. Construct message 23 in that way that the EUT will be addressed by the message.

iii) Apply a \$PIWWIVD assignment input with a reporting interval of 2 seconds.

b) Required results

i) Verify that the reporting interval is 5 seconds.

ii) Verify that the EUT ignores the command given by message 23.

iii) Verify that the EUT ignores the assignment command given by \$PIWWIVD.

3. Increased reporting interval assignment
 - a) Increased reporting interval assignment by \$PIWWIVD
 - i) Method of measurement

Set up the standard test environment and operate EUT in autonomous mode.

 - Apply a \$PIWWIVD assignment to the EUT with a reporting interval greater than the autonomous reporting interval.
 - Apply a \$PIWWIVD assignment to the EUT with a reporting interval shorter than the autonomous reporting interval.

Record transmitted messages.
 - ii) Required results
 - Confirm that the EUT transmits position reports with the autonomous reporting interval in \$PIWWIVD.
 - Verify that EUT switches to assigned mode and transmits position reports with 2 seconds reporting interval. Verify that EUT reverts to autonomous mode after time out period.
4. Addressing by station type
 - a) Method of measurement

Set up standard test environment and operate EUT in autonomous mode with a reporting interval of 10 seconds.

 - i) Transmit a Group Assignment command (message 23) to the EUT (define geographic region so that the EUT is inside this region). Set the reporting interval to 2 seconds and the station type to 0 (all stations).
 - ii) Transmit a Group Assignment command (message 23) to the EUT (define geographic region so that the EUT is inside this region). Set the reporting interval to 2 seconds and the station type to 1 (Class A), 2 (Class B), 3 (SAR aircraft), 4 (Class B SO), 5 (Class B CS).
 - iii) Transmit a Group Assignment command (message 23) to the EUT (define geographic region so that the EUT is inside this region). Set the reporting interval to 5 seconds and the station type to 6 (Inland Waterway). Apply this message to the VDL again within 4 minutes. Record VDL and check reaction of the EUT.
 - b) Required result
 - i) Verify that EUT switches to assigned mode and transmits position reports with 2 seconds reporting interval. Verify that EUT reverts to autonomous mode after time out period.
 - ii) Verify that EUT declines message 23.
 - iii) Verify that EUT switches to assigned mode and transmits position reports with 5 seconds reporting interval. Verify that EUT reverts to autonomous operation mode after time out period of second transmitted group assignment.

Article 9.02
Inland AIS message formats

1. Received Inland specific messages

a) Method of measurement

Set up standard test environment and operate EUT in autonomous mode.

- i) Apply following Inland specific messages using binary message (message 8) to the VDL:
 - Inland ship static and voyage related data Inland specific RFM 10 (DAC 200 / FI 10);
 - Inland number of persons onboard Inland specific RFM 55 (DAC 200 / FI 55);
 - Number of persons on board International Function message 16 (DAC 001 / FI 16).
- ii) Apply following addressed Inland specific messages using binary message (message 6; EUT as destination) to the VDL.
 - Inland number of persons onboard Inland specific RFM 55 (DAC 200 / FI 55);
 - Number of persons on board International Function message 16 (DAC 001 / FI 16).
- iii) Apply an addressed Inland specific message using addressed binary message (message 6; other station as destination) to the VDL.
- iv) Apply position report (message 1, 2 or 3) with parameter "Blue Sign set" and static and voyage related data (message 5) to the VDL.

Record transmitted messages and frame structure.

b) Required results

- i) Confirm that EUT outputs the received message via the presentation interface properly. If implemented confirm that EUT displays received Inland specific message accordingly. Confirm that the content of RFM 10 is displayed according to Table VI-4.
- ii) Confirm that EUT outputs the received message via the presentation interface properly. Check that EUT transmits the appropriate acknowledgement message for addressed messages. If implemented confirm that EUT displays received Inland specific message accordingly.
- iii) Confirm that the EUT does not output the message 6 (addressed to other station) on the presentation interface. If implemented confirm that EUT does not display the received Inland specific message addressed to other station as destination.
- iv) Confirm that EUT outputs the received message via the presentation interface properly. If implemented confirm that EUT displays the information "Blue Sign set" only when Inland ship static and voyage related data RFM 10 (using message 8) has been received before.

2. Transmitted inland specific messages

Set up standard test environment and operate EUT in autonomous mode. Apply all static, dynamic and voyage related data to the EUT (over MKD, \$--SSD, \$--VSD, \$PIWWIVD and \$PIWWSSD). Record all messages on VDL and check the contents of the relevant messages. For all sub-points make sure that values transmitted to the EUT by MKD or PI sentences are stored in the EUT even after disconnecting the power supply. Examine VDL messages of EUT and figure out if defined values are used.

a) Position report message 1, 2 or 3

Blue Sign information may be derived by a direct connected switch or by the regional bits of the periodically received PI sentence (\$--VSD). The presence of the direct connected switch shall be made available by automatic means or manual configuration. Ensure that Blue Sign information derived from direct connected switch has precedence of transferred REF#IEC-61162-1 commands (regional bits of \$--VSD sentence).

i) Method of measurement

Set up standard test environment and operate EUT in autonomous mode.

- Apply a valid VSD sentence with the regional application flag set to:
 - “Blue Sign not set” (0100bin),
 - “Blue Sign is set” (1000bin),
 - “Blue Sign information is not available” (0000bin).
- Set the input data for Blue Sign information in VSD to invalid (e.g. wrong checksum).
- Apply a valid VSD sentence with the regional application flag set to 2. Disconnect VSD input for Blue Sign information.
- Connect Blue Sign switch to EUT in a way that the Blue Sign value is set to 1 (= not set).
- Change Blue Sign value to 2 (= set) by direct connected switch to EUT.
- Change Blue Sign value to 1 (= not set) by applying VSD sentence (regional bits of VSD sentence) to EUT.
- Disconnect Blue Sign switch from EUT in a way that Blue Sign value is set to 0 (= not available).

- ii) Required results
 - Check the parameter Blue Sign in VDL message 1, 2, 3:
 - 1 = not engaged in special manoeuvre (Blue Sign not set),
 - 2 = engaged in special manoeuvre (Blue Sign set),
 - 0 = not available.
 - Confirm that EUT transmits message 1 or 2 or 3 with Blue Sign value accordingly.
 - Confirm that EUT does not transmit message 5 for unchanged data derived from PI sentence (VSD).
 - Confirm that EUT switches Blue Sign value to 0 (= not available) within 2 seconds after invalid input (check PI Output, VDO sentence) and that EUT transmits message 1 or 2 or 3 with Blue Sign value 0 (= not available).
 - Confirm that EUT switches Blue Sign value to 0 (= not available) within 2 seconds after invalid input (check PI Output, VDO sentence) and that EUT transmits message 1 or 2 or 3 with Blue Sign value 0 (= not available).
 - Confirm that EUT transmits message 1 or 2 or 3 with Blue Sign value 1 (= not set).
 - Confirm that EUT transmits message 1 or 2 or 3 with Blue Sign value 2 (= set).
 - Confirm that EUT ignores Blue Sign information derived from VSD sentence.
 - Confirm that EUT transmits message 1 or 2 or 3 with Blue Sign value 0 (= not available).
- b) Ship static and voyage related data (Message 5 and RFM 10)
 - i) Method of measurement

Operate EUT in autonomous mode and record messages on VDL.

 - Configure several relevant ship and convoy combinations (in minimum it shall be tested for all extensions set to 0 (own ship only) and all extensions set to values not 0 and for internal and external position source).
 - Configure several Inland vessel and convoy types.
 - Configure ship and cargo type for message 5.
 - Configure draught in dm.
 - Switch off EUT by disconnecting power supply. Reconnect Power and record messages on VDL.
 - ii) Required results
 - Confirm that EUT transmits the correct A, B, C, D values rounded up in message 5 and correct length and beam in RFM 10 according to the calculations defined in Part III, Article 6.03(1) with the specified accuracy.
 - Confirm that EUT transmits the correct Inland vessel and convoy type in RFM 10 and the converted ship and cargo type in message 5.

- Confirm that EUT transmits the correct ship and cargo type in message 5.
 - Confirm that EUT transmits the correct draught in cm in RFM 10 and in dm rounded up in message 5.
 - Confirm that the EUT transmits message 5 and RFM 10 with values unchanged.
- c) Persons on board RFM 55 (DAC 200 / FI 55)
- This message shall be used by inland vessels only, to send the number of persons on Board to a competent authority in order to inform about the number of persons on board. The message shall be sent with binary message 6 RFM 55 (DAC 200, FI 55).
- i) Method of measurement
 - Initiate transmission of persons on board message as RFM 55 by MKD.
 - Initiate transmission of persons on board message as RFM 55 by ABM.
 - Initiate transmission of persons on board message as RFM 55 by BBM.
 - ii) Required results
 - Confirm that EUT transmits AIS message 6 with proper content (check all numbers) as RFM 55.
 - Confirm that EUT transmits AIS message 6 with proper content as RFM 55.
 - Confirm that EUT transmits AIS message 8 with proper content as RFM 55.
3. Transmit inland specific interrogation messages
- a) Transmit an interrogation for a specific FM (IFM 2)
- i) Method of measurement
 - Set up standard test environment and operate EUT in autonomous mode.
 - Apply an ABM sentence containing an IFM 2 (Interrogation for a specific FM) using binary message 6 to request "Inland ship and voyage related data (RFM 10)". Record transmitted messages.
 - Send an IFM 2, request DAC = 200 and requested FI = 10.
 - Send an IFM 2, request DAC = 200 and requested FI = 55.
 - Send an IFM 2, request DAC = 303 and requested FI = 10.
 - ii) Required results
 - Check that EUT reacts as follows:
 - Verify that EUT sends interrogation message on VDL using binary message 6 and that DAC FI and requested DAC are correct;
 - Verify that EUT sends interrogation message on VDL using binary message 6 and that DAC FI and requested DAC are correct;
 - Verify that EUT sends interrogation message on VDL using binary message 6 and that DAC FI and requested DAC are correct.

4. Response to inland specific interrogation messages

a) Response to “Capability interrogation” (IFM 3) with “Capability reply” (IFM 4)

i) Method of measurement

Set up standard test environment and operate EUT in autonomous mode.

- Apply an IFM 3 (Capability interrogation) using addressed binary message (message 6) to the VDL with requested DAC = 200. Record transmitted messages.
- Repeat the test with DAC = 303.
- Repeat the test with DAC = 001.

ii) Required results

- Check that the EUT transmits the appropriate response “Capability reply” (IFM 4) using addressed binary message (message 6) addressed to the interrogator. Check the content of this message in accordance to the specification in REF#ITU-R1371. Bit order of ‘FI capability table’:

first	sec.	first	sec.	first	sec.					first	sec.	first	sec.
FI 0		FI 1		FI 2						FI 62		FI 63	

Verify that at least the DAC 200 / FI 10 and DAC 200 / FI 55 for Inland AIS are included in the binary structure. Confirm that the EUT transmits the response on the same channel as where the request was received.

- Check that the EUT transmits the appropriate response “Capability reply” (IFM 4) using addressed binary message (message 6) addressed to the interrogator. Check the content of this message in accordance to the specification in REF#ITU-R1371. Confirm that the EUT does respond with all values set to 0. Confirm that the EUT transmits the response on the same channel as where the request was received.
- Check that the EUT transmits the appropriate response “Capability reply” (IFM 4) using addressed binary message (message 6) addressed to the interrogator. Check the content of this message in accordance to the specification in REF#ITU-R1371.

Verify that at least the DAC 001 / FI 3 is included in the binary structure. Confirm that the EUT transmits the response on the same channel as where the request was received.

b) Response to interrogation for “Inland ship static and voyage related data” (RFM 10)

i) Method of measurement

Set up standard test environment and operate EUT in autonomous mode. Apply an IFM 2 (Interrogation for a specific FM) using binary message 6 to request “Inland ship and voyage related data” (RFM 10) to the VDL. Record transmitted messages.

- Request “Inland ship and voyage related data” (RFM 10) with DAC = 200, FI 10.
- Request “Inland ship and voyage related data” (RFM 10) with DAC = 303, FI 10.

- ii) Required results
Check that EUT reacts as follows:
 - EUT shall respond to interrogation with “Inland ship and voyage related data” (RFM 10) using binary message 6;
 - EUT shall not respond.
- c) Response to interrogation for “Number of Persons on board” (RFM 55 and IFM 16)
 - i) Method of measurement
Set up standard test environment and operate EUT in autonomous mode.
Apply an International Function message IFM 2 (Interrogation for a specific FM) using binary message 6 to request Inland number of persons onboard to the VDL. Record transmitted messages.
 - Request “number of persons on board” with DAC = 200, FI 55.
 - Request “number of persons on board” with DAC = 303, FI 55.
 - ii) Required results
Check that EUT reacts as follows:
 - Confirm that EUT transmits AIS message 6 with proper content (check all numbers) as inland specific RFM 55;
 - EUT shall not respond.

CHAPTER 10

SHIPBORNE INLAND AIS STATIONS - HIGH SPEED INPUT

This test checks the configuration of the Inland AIS unit using the high speed input port.

Article 10.01

Voyage data configuration

1. Method of measurement
 - a) Apply a VSD sentence with voyage related data.
 - b) Apply a PIWWIVD sentence with Inland specific voyage data.
 - c) Apply a VSD sentence with voyage related data with draught deviating from b.
 - d) Apply a query for VSD.

2. Required result
 - a) Confirm that all data are accepted with exception of the draught.
 - b) Confirm that all Inland specific voyage data are accepted with full resolution with EPV sentence and IWWIVD sentence.
 - c) Confirm that the draught from VSD is ignored.
 - d) Confirm that a VSD and a PIWWIVD sentence are output with correct data.

Article 10.02

Static data configuration

1. Method of measurement
 - a) Apply a PIWWSSD sentence with static data, no preceding SPW sentence.
 - b) Apply a PIWWSSD sentence with static data, preceding SPW sentence with incorrect password.
 - c) Apply a PIWWSSD sentence with static data, preceding SPW sentence with correct password.
 - d) Apply a SSD sentence with static data different to the currently stored values, preceding SPW sentence with correct password.
 - e) Apply a query for SSD.

2. Required result
 - a) Confirm that the data which are protected according to Table VI-7 are not accepted. Confirm that the other data are accepted.
 - b) Confirm that the data which are protected according to Table VI-7 are not accepted. Confirm that the other data are accepted.

- c) Confirm that all static data of the PIWWSSD sentence are accepted.
- d) Confirm that the A, B, C, D values are ignored and all other static data of the SSD sentence are accepted.
- e) Confirm that a SSD and a PIWWSSD sentence are output with correct data and accuracy.

CHAPTER 11
SHIPBORNE INLAND AIS STATIONS - LONG RANGE FUNCTIONALITY TESTS

Not mandatory for Inland AIS.

CHAPTER 12

INLAND AIS ATON STATIONS - REQUIREMENTS

Article 12.01

General requirements

The Inland AIS Aton station is based on the specification of AIS AtoN stations in accordance with REF#ITU-R1371 and International Standard REF#IEC-62320-2 unless otherwise stated.

Article 12.02

Performance requirements

The following performance requirements apply in addition to those of REF#IEC-62320-2.

For Inland AIS AtoNs only page ID 1 is to be transmitted. No other page IDs shall be transmitted by Inland AIS AtoNs

Article 12.03

Configuration method

The configuration method shall be as defined by the manufacturer and held in non-volatile memory. Configuration may use standard configuration sentences either directly or via the VDL. Query for the encryption key is not allowed. The configuration method shall add the following in addition to the provisions of REF#IEC-62320-2:

- a) configure the content for Message 21 of page ID 1 with "Types of Inland Aids-to-navigation";
- b) configure the direction of impact for certain Inland AIS AtoNs using the name parameter.

The manufacturer shall provide a means to verify configuration and version information of the Inland AIS AtoN Station.

CHAPTER 13
INLAND AIS ATON STATIONS – TEST OF PHYSICAL INLAND AIS ATON
STATION

Article 13.01
Aim

Test the features which are special for Inland AtoNs in addition to the AIS AtoN REF#IEC-62320-2.

Article 13.02
Requirements

1. Means to configure the parameter field 'AtoN status' (NMEA 0183 configuration sentence ACG)
2. Select parameter field 'AtoN status' page ID 1
3. Configure page ID 1 with Types of Inland Aids to Navigation
4. Automatically set in message 21 "Type of aids-to-navigation" = 0
5. No other page ID than ID 1 is allowed for transmission
6. Restrict MMSI to MID 2xx only (see Part II, Chapter 5, Article 5.03, Number 10)
7. Inland AtoN that require a direction of impact must always include a direction of impact in the name field, however, the name is optional.
8. Input "direction of impact of the AtoN" in the parameter "Name of Aids to Navigation", only a three digit number between 000 and 359 can be used¹.
9. The manuals shall also cover the methods necessary to support the Inland AtoN specific function.

¹ In addition to the name (at the end), the content of the parameter contains two percent symbols '%' directly followed by the direction of impact in full degrees clockwise starting from North, e.g. %%270 for direction of impact 270 degrees. This information may be transmitted with or without preceding name value.

Article 13.03

Method of tests

Check that Message 21 always has set a type of Inland AtoN (not 00000000), otherwise don't transmit Message 21

- a) Configure the EUT with the general settings of an AIS AtoN report message 21 as maritime AIS AtoN with a "Type of aids-to-navigation" not = 0 using an MMSI with MID not = 2xx and operate the AIS AtoN station, tx Message 21 with the appropriate reporting interval, monitor the VDL.
- b) Configure maritime AIS AtoN with a "Type of aids-to-navigation" = 0 and page ID 1 with a code for a Type of Inland Aids to Navigation using the ACG sentence and an MMSI with MID not = 2xx.
- c) Configure maritime AIS AtoN with a "Type of aids-to-navigation" = 0 and page ID 1 with a code for a Types of Inland Aids to Navigation using an MMSI with MID = 2xx.
- d) Configure page ID 1 with a code for a Type of Inland Aids to Navigation which has a direction of impact and a name field with a name but no direction of impact.
- e) Configure page ID 1 with a code for a Type of Inland Aids to Navigation filled in with a direction of impact and no other name information, eg. "%%030".
- f) Configure page ID 1 with a code for a Type of Inland AIS Aids to Navigation filled in with a direction of impact and no other name information. Direction of impact is higher than "%%359".
- g) Configure page ID 1 with a code for a Type of Inland Aids to Navigation which has no direction of impact and a name field with a direction of impact.
- h) Configure page ID 1 with a code for a Type of Inland Aids to Navigation filled in with a name information of less than 15 characters and a direction of impact at the end of the name.
- i) Configure page ID 1 with a code for a Type of Inland Aids to Navigation filled in with a name information of more than 15 characters and direction of impact at the end of the name.
- j) Configure a page ID other than 1, e.g. page ID 7 and set the status bits to a desired value.

Article 13.04

Required results

- a) Verify that the EUT is transmitting message 21 as configured.
- b) Verify that the EUT does not accept the configuration for page ID 1 and the "Types of Inland Aids to Navigation" as configured and stops transmitting message 21.
- c) Verify that the EUT is transmitting message 21 with page ID 1 and the "Types of Inland Aids to Navigation" as configured and the parameter "Type of aids-to-navigation" = 0.
- d) Verify that the EUT does not accept the setting and does not transmit message 21.

- e) Verify that the EUT is transmitting message 21 with page ID 1 and the “Types of Inland Aids to Navigation” as configured and the code for direction of impact in the name field as configured.
- f) Verify that the EUT does not accept direction of impact higher than “359” and stops transmitting message 21.
- g) Verify that the EUT does not accept direction of impact higher than “359” and stops transmitting message 21.
- h) Verify that the EUT is transmitting message 21 with page ID 1 and the “Types of Inland Aids to Navigation” as configured and the code for direction of impact and the name in the name field as configured.
- i) Verify that the EUT is transmitting message 21 with page ID 1 and the “Types of Inland Aids to Navigation” as configured and the code for direction of impact and the name in the name field as configured, the name is split between the name field and the extended name field after 20 characters.
- j) Verify that the EUT does not accept any other page ID than 1 and that no other page ID is transmitted.

**EUROPEAN STANDARD FOR RIVER INFORMATION SERVICES
ANNEXES**

European Committee for drawing up Standards in the field of Inland Navigation
(CESNI)

Edition 2025/1

**EUROPEAN STANDARD FOR RIVER INFORMATION SERVICES
ANNEXES**

Annexes 1 to 8

ANNEX 1

PRODUCT SPECIFICATION FOR IENCS, EDITION 2.5

TABLE OF CONTENTS

1.	INTRODUCTION.....	295
2.	GENERAL INFORMATION	295
2.1	NAVIGATIONAL PURPOSE (USAGE).....	295
2.2	CELLS	296
2.3	TOPOLOGY	296
3.	FEATURES AND ATTRIBUTES	297
3.1	FEATURE OBJECT IDENTIFIERS	297
3.2	STANDARD FEATURES AND ATTRIBUTES.....	297
3.3	FEATURES PERMITTED FOR USE IN IENC AND THEIR GEOMETRIC PRIMITIVES.....	297
3.4	META FEATURES	297
3.5	GEO AND META FEATURE ATTRIBUTES	297
3.5.1	<i>Missing enumerations</i>	297
3.5.2	<i>Mandatory attributes</i>	297
3.5.3	<i>Prohibited attributes</i>	298
3.5.4	<i>Numeric enumerations</i>	298
3.5.5	<i>Text enumerations</i>	298
3.5.6	<i>Hierarchy of meta data</i>	298
3.6	CARTOGRAPHIC FEATURES	299
3.7	TIME VARYING FEATURES	299
3.8	GEOMETRY	299
3.9	RELATIONSHIPS	299
3.10	GROUPS	300
3.10.1	<i>Group 1 (skin of the earth)</i>	300
3.10.2	<i>Group 2 (all other features)</i>	300
3.11	LANGUAGE AND ALPHABET	300
3.11.1	<i>Language</i>	300
3.11.2	<i>Use of lexical level 2</i>	300
4.	CARTOGRAPHIC FRAMEWORK	301
4.1	HORIZONTAL DATUM.....	301
4.2	VERTICAL AND SOUNDING DATUM	301
4.3	PROJECTION	301
4.4	UNITS	301
5.	PROVISION OF DATA	302
5.1	IMPLEMENTATION	302
5.2	COMPRESSION	302
5.3	ENCRYPTION.....	302

5.4	EXCHANGE SET	303
5.4.1	<i>Content of the exchange set</i>	303
5.4.2	<i>Volume naming</i>	304
5.4.3	<i>Directory structure</i>	304
5.5	DATA SETS	305
5.6	FILE NAMING	305
5.6.1	<i>README file</i>	305
5.6.2	<i>Catalogue file</i>	305
5.6.3	<i>Data set files</i>	305
5.6.4	<i>Text and picture files</i>	306
5.7	UPDATING	307
5.8	MEDIA	309
5.9	ERROR DETECTION	309
5.9.1	<i>Implementation</i>	309
5.9.2	<i>Processing</i>	310
6.	APPLICATION PROFILES	310
6.1	GENERAL	310
6.1.1	<i>Catalogue and data set files</i>	310
6.1.2	<i>Records</i>	311
6.1.3	<i>Fields</i>	311
6.1.4	<i>Subfields</i>	311
6.2	CATALOGUE FILE	311
6.2.1	<i>Catalogue file structure</i>	311
6.2.2	<i>Catalogue Directory field - CATD</i>	312
6.3	EN APPLICATION PROFILE	312
6.3.1	<i>Base cell file structure</i>	313
6.3.2	<i>Field content (EN)</i>	314
6.4	ER APPLICATION PROFILE	319
6.4.1	<i>Update cell file structure</i>	320
6.4.2	<i>Field content (ER)</i>	321
7.	MAINTENANCE	327
Appendix 1	IENC Feature Catalogue, Edition 2.5.1, 2021-04-21 (Distributed separately)	
Appendix 2	Encoding Guide for IENCs, Edition 2.5.1, 2021-04-21 (Distributed separately)	

1. Introduction

Inland Electronic Navigational Chart (IENC) means the database, standardized as to content, structure and format, for use with Electronic Chart Display and Information System for inland navigation operated onboard of vessels transiting inland waterways. An IENC is issued by or on the authority of a competent government agency, and conforms to standards developed by the International Hydrographic Organization (IHO) and refined by the IENC Harmonization Group (IEHG). An IENC contains all the chart information necessary for safe navigation on inland waterways and may contain supplementary information in addition to that contained in the paper chart (e.g. sailing directions, machine-readable operating schedules, etc) which may be considered necessary for safe navigation and voyage planning.

This Product Specification for IENC is a set of specifications intended to enable ENC manufacturers to produce consistent IENC, and to use data efficiently in applications. An IENC shall be produced in accordance with the regulations defined in:

- this Product Specification for IENC,
- the Feature Catalogue for IENC,
- the Encoding Guide for IENCs.

The numbering correlates to the ENC Product Specification, REF#IHO-S57 Appendix B.1, Edition 2.0.

2. General Information

2.1 Navigational purpose (usage)

IENC data is compiled for a variety of navigational purposes. The navigational purpose for which an individual IENC has been compiled is indicated in the “Data Set Identifier” [DSID] field, “Intended Usage” [INTU] subfield and in the name of the data set files. The following codes are used:

Nr.	Navigational (purpose (usage))	Intended use
1 REF#IHO-S57	Overview	For route planning and oceanic crossing.
2 REF#IHO-S57	General	For navigating oceans, approaching coasts and route planning.
3 REF#IHO-S57	Coastal	For navigating along the coastline, either inshore or offshore.
4 REF#IHO-S57	Approach	Navigating the approaches to ports or mayor channels or through intricate or congested waters.
5 REF#IHO-S57	Harbour	Navigating within ports, harbours, bays, rivers and canals, for anchorages.
6 REF#IHO-S57	Berthing	Detailed data to aid berthing.
7 (new)	River	Navigating the inland waterways (skin cell).
8 (new)	River harbour	Navigating within ports and harbours on inland waterways (skin cell).

Nr.	Navigational (purpose (usage)	Intended use
9 (new)	River berthing	Detailed data to aid berthing manoeuvring in inland navigation (skin cell).
A (new)	Overlay	Overlay cell to be displayed in conjunction with skin cells

The navigational purposes 1 to 8 and A may be used by authorities as well as private bodies. Navigational purpose 9 should be used by private bodies only.

It is allowed to assign a range of usages to overlay cells (see paragraph 5.6.3).

Overlay cells may not contain skin-of-the-earth features (see paragraph 3.10).

2.2 Cells

In order to facilitate the efficient processing of ENC data the geographic coverage of a given usage must be split into cells. Each cell of data must be contained in a physically separate, uniquely identified file on the transfer medium, known as a data set file (see paragraph 5.4 and 5.6.3).

The geographic extent of the cell must be chosen by the ENC producer to ensure that the resulting data set file contains no more than 5 Megabytes of data. Subject to this consideration, the cell size must not be too small in order to avoid the creation of an excessive number of cells.

The coordinates of the borders of the cell are encoded in decimal degrees in the "Catalogue Directory" [CATD] field.

Point or line feature objects which are at the border of two cells with the same navigational purpose must be part of only one cell. They are put in the south or west cell (i.e. north and east borders of the cell are part of the cell, south and west borders are not).

When a feature object exists in several cells its geometry must be split at the cell boundaries and its complete attribute description must be repeated in each cell.

In IENC, skin-of-the-earth features (group 1) within two overlapping cells with the same navigational purpose must not overlap. Features of overlay cells (always group 2) are allowed to overlap other features in other cells.

The minimum size of coverage at both sides of the waterway should be outside the radar coverage.

2.3 Topology

ENC data must be encoded using chain-node topology (see REF#IHO-S57 Part 2, clause 2.2.1.2).

3. Features and attributes

3.1 Feature object identifiers

Each feature object must have a unique world-wide identifier. This identifier, called the feature object identifier, is formed by the binary concatenation of the contents of the subfields of the "Feature Object Identifier" [FOID] field.

For IENC the feature object identifier may be used to identify multiple instances of the same feature. For example, the same feature may appear in different usages, or a feature may be split by the cell structure. In these circumstances each instance of this feature may have the same identifier. Feature object identifiers must not be reused, even when a feature has been deleted.

3.2 Standard features and attributes

Only features, attributes and enumerations which are defined in the IENC Feature Catalogue at <http://ienc.openecdis.org> may be used in an IENC.

3.3 Features permitted for use in IENC and their geometric primitives

The geometric primitives of the features permitted for use in IENC can be found in the Annex 1, Appendix 2.

3.4 Meta features

The maximum use must be made of meta features to reduce the attribution on individual features. In a base data set (EN Application profile, see paragraph 6.3), some meta features are mandatory (see Annex 1, Appendix 2).

3.5 Geo and meta feature attributes

3.5.1 Missing enumerations

In a base data set (EN application profile), when an attribute code is present but the enumeration is missing, it means that the producer wishes to indicate that this enumeration is unknown.

In a revision data set (ER application profile), when an attribute code is present but the enumeration is missing it means:

- that the enumeration of this attribute is to be replaced by an unknown enumeration if it was present in the original data set,
- that an unknown enumeration is to be inserted if the attribute was not present in the original data set.

In both cases the missing enumeration is encoded by the means described in REF#IHO-S57 Part 3, clause 2.1.

3.5.2 Mandatory attributes

For mandatory attributes of features see Annex 1, Appendix 2.

3.5.3 Prohibited attributes

not applicable.

3.5.4 Numeric enumerations

Floating point or integer enumerations must not be padded by non-significant zeroes.

E.g.: For a signal period of 2.5 sec, the enumeration of SIGPER must be 2.5 and not 02.500.

3.5.5 Text enumerations

The lexical level used for the "Feature Record Attribute" [ATTF] field must be 1 (REF#ISO-IEC-8859-1). Lexical level 1 or 2 may be used for the "Feature Record National Attribute" [NATF] field. Format effecting (C0) characters as defined in REF#IHO-S57 Part 3, Annex B are prohibited. The delete character is only used in the update mechanism (see REF#IHO-S57 part 3, clause 8.4.2.2.a and 8.4.3.2.a).

3.5.6 Hierarchy of meta data

The following table indicates:

- individual attributes that supersede meta feature attributes,
- meta feature attributes that supersede the data set subfields (see paragraph 6.3.2 and 6.4.2).

Field	Subfield	Meta feature class	Meta feature attribute	Geo or spatial feature attribute
DSPM	VDAT	m_vdat	Verdat	verdat
DSPM	SDAT	m_sdat	Verdat	verdat
		m_nsys	Marsys	marsys
		M_QUAL	CATZOC	POSACC, SOUACC and TECSOU
		M_QUAL	SOUACC	SOUACC
		M_QUAL	POSACC	POSACC
		M_SREL	QUASOU	QUASOU
		M_SREL	SURATH	SORIND
		M_SREL	SUREND	SORDAT
		M_SREL	SURSTA	SORDAT
		M_SREL	TECSOU	TECSOU
		M_ACCY	POSACC	POSACC
		M_ACCY	SOUACC	SOUACC
		M_ACCY	VERACC	VERACC
		M_ACCY	HORACC	HORACC
		M_ACCY	CATTEV	CATTEV

When there is no meta feature attribute, an individual attribute can supersede a data set subfield.

It is prohibited to use an attribute on an individual feature, if this attribute has the same enumeration as the general enumeration defined by the meta feature or the equivalent data set subfield.

It is prohibited to use a meta feature, if the information given by this meta feature is the same as the enumeration given by the equivalent data set subfield.

3.6 Cartographic features

not applicable.

3.7 Time varying features

The IENC may contain information about magnetic variation, tides, tidal streams and currents. The IENC may contain time independent depth information in accordance with the Annex 1, Appendix 2.

3.8 Geometry

Edges must be encoded using SG2D fields only. ARCC fields (curves) must not be used.

Despite the saving in data volume offered by the use of arcs/curves, the disadvantages are such (e.g. during updating, generating warnings/alarms) that they must not be used for IENC.

Linear features must not be encoded at a point density greater than 0.3 mm at compilation scale.

The presentation of symbolised lines may be affected by line length. Therefore, the encoder must be aware that splitting a line into numerous small edges may result in poor symbolisation.

In certain circumstances, the symbolisation of an edge may need to be suppressed. This is done using the value {1} in the "Masking Indicator" [MASK] subfield of the "Feature Record to Spatial Record Pointer" [FSPT] field. If the value in the "Usage Indicator" [USAG] subfield is set to {3} (exterior boundary truncated by the data limit), the MASK subfield must be set to {255} (null), in all other cases it must set to {2}.

3.9 Relationships

There are two ways to define relationships between features:

- nominated master feature record,
- collection features of classes "aggregation" (C_AGGR), or "association" (C_ASSO).

The use of the Catalogue Cross Reference record is prohibited.

All hierarchical relationships (master to slave) must be encoded by using a nominated “master” feature record carrying the pointers to the “slave” features in the “Relationship Indicator” [RIND] subfield in the “Feature Record to Feature Object Pointer” [FFPT] field with the value {2} = slave.

All association or aggregation relationships using collection features are assumed to be peer to peer. The “Relationship Indicator” [RIND] subfield of these collection feature records must be {3} = peer.

The use of these relationships is described in the Annex 1, Appendix 2.

3.10 Groups

There are two groups defined for IENC. These are Group 1 (skin of the earth) and Group 2 for all other geo feature objects.

The group number is indicated in the “Group” [GRUP] subfield of the “Feature Record Identifier” [FRID] field.

3.10.1 Group 1 (skin of the earth)

Each area covered by a meta feature M_COVR with CATCOV = 1 must be totally covered by a set of geo features of type area that do not overlap each other (the skin of the earth).

These features make up Group 1.

The list below contains the features that must always be in Group 1, if they appear in the dataset and if they are of type area.

DEPARE, depare, DRGARE, FLODOC, HULKES, LNDARE, PONTON, UNSARE;

flodoc, hulkes and ponton are not Group 1 features.

3.10.2 Group 2 (all other features)

All feature objects which are not in Group 1 are in Group 2.

3.11 Language and alphabet

3.11.1 Language

See Annex 1, Appendix 2.

3.11.2 Use of lexical level 2

If the national language cannot be expressed in lexical levels 0 or 1, the following rules apply:

- the exact spelling in the national language is encoded in the “Feature Record National Attribute” [NATF] field using lexical level 2.

- translated text, including transliterated or transcribed national geographic names is encoded in the “Feature Record Attribute” [ATTF] field using lexical level 0 or 1.

Where possible international standards should be used for the transliteration of non-Latin alphabets.

4. Cartographic framework

4.1 Horizontal datum

The horizontal datum must be WGS 84. Therefore, the “Horizontal Geodetic Datum” [HDAT] subfield in the “Data Set Parameter” [DSPM] field must have the value of {2}.

The boatmaster may have to display information other than IENC data and IENC updates. In cases where this information is based on a horizontal datum other than WGS-84, it can be converted to WGS 84 by means of the meta feature Horizontal datum shift parameter (M_HOPA).

In the case that the data are transformed to WGS-84 from a local datum the responsible authority shall define the area where the local transformation parameters apply. Within this area, the difference between transformed coordinates and the surveyed WGS-84 coordinates may not exceed 0.5 m. For approval purposes, the responsible authority shall define appropriate reference points (surveyed WGS-84 coordinates) preferably exactly at the limit line of two adjacent areas. Reference points, transformation parameters and the algorithm shall be published and shall be the basis for IENC production for that area.

4.2 Vertical and sounding datum

The various levels which are used on paper charts for elevations and soundings will be used. The default values are encoded in the “Vertical Datum” [VDAT] subfield and the “Sounding Datum” [SDAT] subfield in the “Data Set Parameter” [DSPM] field.

4.3 Projection

No projection is used, therefore the “Data Set Projection” [DSPR] field must not be used. Coordinates must be encoded as geographical positions (latitude, longitude).

4.4 Units

Units to be used in an IENC are:

- Position: latitude and longitude in decimal degrees (converted into integer values, see below).
- Depth: metres.
- Height: metres.
- Positional accuracy: metres.
- Distance: nautical miles, statute miles, kilometres or metres as defined in the IENC Feature Catalogue.

The default values for depth units, height units and positional accuracy units are encoded in the “Units of Depth Measurement” [DUNI], “Units of Height Measurement” [HUNI] and “Units of Positional Accuracy” [PUNI] subfields in the “Data Set Parameter” [DSPM] field.

Latitude and longitude values are converted from decimal degrees to integers by means of the “Coordinate Multiplication Factor” [COMF] subfield value in the “Data Set Parameter” [DSPM] field. The integer values are encoded in the “Coordinate in Y-axis” [YCOO] subfield and the “Coordinate in X-axis” [XCOO] subfield. The number of decimal digits is chosen by the data producer and is valid throughout the data set.

E.g.: If the producer chooses a resolution of 0.0001° (10-4), then the value of COMF is 10 000 (104).

A longitude = 34.5678° is converted into $XCOO = \text{longitude} * COMF = 34.5678 * 10\ 000 = 345678$.

The integer value of the converted coordinate is encoded in binary form.

Depths are converted from decimal meters to integers by means of the “3-D (Sounding) Multiplication Factor” [SOMF] subfield value in the “Data Set Parameter” [DSPM] field. The integer values are encoded in the “3-D (Sounding) Value” [VE3D] subfield. Soundings are never encoded with a resolution greater than one decimetre, so the value of SOMF must be 10 encoded in binary form.

5. Provision of data

5.1 Implementation

The binary implementation of REF#IHO-S57 must be used for IENC. Therefore, the “Implementation” [IMPL] subfield of the “Catalogue Directory” [CATD] field must be set to “BIN” for the data set files.

5.2 Compression

The use of compression algorithms is prohibited.

5.3 Encryption

IENC data may be protected from unauthorised use, possibly by the use of encryption algorithms.

5.4 Exchange set

5.4.1 Content of the exchange set

The records defined in this Annex are grouped in two file types: catalogue and data set files.

An exchange set is composed of one and only one catalogue file and at least one data set file.

Text and picture files may also be included in the IENC exchange set. These files may be included in an exchange set by a data producer to provide additional information such as that normally contained in sailing directions or coastal pilots. For format of these files see Annex 1, Appendix 2.

An exchange set may also contain a README file.

Exchange set

```
|  
|--<1>-- README file  
|  
|--<1>-- Catalogue file  
|  
|--<R>-- Data set file  
|  
|--<R>-- Text file  
|  
|--<R>-- Picture file
```

The README file is an optional ASCII file of general information.

The catalogue file acts as the table of contents for the exchange set.

Each data set file contains data for one cell (see paragraph 2.2). This includes:

- data set descriptive information that is specific to the data set,
- the description and location of the real-world entities.

Text and picture files do not conform to REF#ISO-IEC-8211. These files are specific to this Product Specification.

5.4.2 Volume naming

An exchange set may be split across several media volumes, therefore, each media volume must be uniquely identified within the exchange set. A file must not be split across volumes. Individual volumes must conform to the following naming convention:

VSSXNN

where:

- V is the mandatory first character.
- SS is the sequence number of the specific volume within the exchange set.
- X is the mandatory separator character.
- NN is the total number of media volumes within the exchange set.

For example, volume one of a three volume exchange set would be named V01X03.

5.4.3 Directory structure

The following directory structure is mandatory.

On each volume within an exchange set there must be a root directory called ENC_ROOT. The catalogue file for the exchange set must be in the ENC_ROOT directory of the first volume of the exchange set. The ENC_ROOT directory of the first volume may also contain a README file, containing ASCII text. Further directories and sub-directories may be defined under the root directory on any volume in the exchange set. The following example shows an example directory structure for a MS-DOS volume:

```
Volume in drive A is V01X02
Directory of A:\ENC_ROOT

.                <DIR>                09-15-96 12:40p  .
..               <DIR>                09-15-96 12:40p  ..
CATALOG          031                1,584          09-15-96 12:46p  CATALOG.031
NL600021         000                45,584         09-15-96 12:50p  NL600021.000
NL600021         001                1,095          09-15-96 12:54p  NL600021.001
NL600021         002                722            09-15-96 12:54p  NL600021.002
README          TXT                504            09-15-96 12:44p  README.TXT
      5 file(s)    49,489 bytes
      2 dir(s)    1,405,952 bytes free
```

For each file in the exchange set the catalogue file must contain the name of the volume on which it is held and the full path name relative to the root directory of that volume. The full path name relative to the root directory must be encoded in the "File Name" [FILE] subfield of the "Catalogue Directory" [CATD] field. The "Long File Name" [LFIL] subfield of the CATD field may be used for other purposes. The full path name of the NL600021.000 file shown in the example is NL600021.000.

5.5 Data sets

Four kinds of data sets may be produced:

- new data set: no IENC data has previously been produced for this area and for the same navigational purpose.
- update: changing some information in an existing data set.
- re-issue of a data set: including all the updates applied to the original data set up to the date of the reissue. A re-issue does not contain any new information additional to that previously issued by updates.
- new edition of a data set: including new information which has not been previously distributed by updates.

Each new data set, re-issue, or new edition is called a base cell file.

A data set containing updates to one base cell file is called an update cell file.

5.6 File naming

5.6.1 README file

README.TXT is the mandatory name for this file.

5.6.2 Catalogue file

The catalogue file of the exchange set must be named CATALOG.EEE.

Where EEE is the edition number of REF#IHO-S57 used for this exchange set, i.e. 031 for the currently [2006] used edition (3.1).

No other file may be named CATALOG.

5.6.3 Data set files

A valid data set file must be uniquely identified worldwide by its name.

The data set files are named according to the specifications given below:

CCPRRRRR.EEE

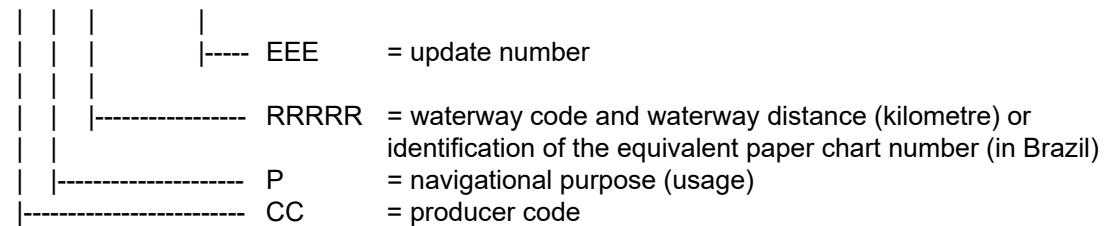

The main part forms an eight-character identifier where:

The first two characters (CC) identify the producer. The list of producer codes is published in the REF#IHO-S100 registry at <http://registry.iho.int>. The list includes all producers which aren't already mentioned in REF#IHO-S62.

The third character (P) indicates the navigational purpose (see paragraph 2.1). The letter "A" (in the position "usage") indicates that the cell is displayed as overlay over other cells within a range of usages. The range of usages of overlay cells is indicated in the Data Set Identifier Field of the header of the overlay cell (see REF#IHO-S57, Part 3, Data Structure, paragraph 7.3.1.1). The 8th bit of the intended usage subfield (INTU) has to be set. The other seven bits describe the range:

Definition of range	from	to
Mathematical description	$(INTU-128) \div 10$	$(INTU-128) \bmod 10$
Example (INTU=207)	$(207-128) \div 10 = 7$	$(207-128) \bmod 10 = 9$

The fourth to eighth characters (RRRRR) identify the waterway and the waterway distance.

- For waterways with a length of more than 999 km: e.g. D1923
- For waterways with a length of more than 99 km: e.g. RH123
- For waterways with a length of more than 9 km: e.g. DCC23

The use of the fourth to eighth characters is only a recommendation.

The primarily produced base cell file has the extension (EEE) 000.

The extension is used for updating. Update cell files have the same name as the original base cell file, with an extension number greater than or equal to 001. They cover the same geographical area as the base cell file to which they apply.

5.6.4 Text and picture files

The text and picture files must be named according to the Annex 1, Appendix 2.

5.7 Updating

In order to ensure that updates are incorporated into the SENC in the correct sequence without any omission, the file extension and a number of subfields in the “Data Set Identifier” [DSID] field are used in the following way:

file extension	every new data set, re-issue or new edition must have a “000” extension. For update cell files the extension is the number of the update, ranging from “001” to “999”. These numbers must be used sequentially, without omission. Number “001” is the first update after a new data set or a new edition, but not after a re-issue. The update sequence is not interrupted by a re-issue. After a re-issue, subsequent updates may be incorporated into the SENC created from this re-issue or to the SENC created from the original data set and kept continuously updated.
edition number	when a data set is initially created, the edition number 1 is assigned to it. The edition number is increased by 1 at each new edition. Edition number remains the same for a re-issue.
update number	update number 0 is assigned to a new data set. The first update cell file associated with this new data set must have update number 1. The update number must be increased by one for each consecutive update, until a new edition is released. The new edition must have update number 0. A re-issue of a data set must have the update number of the last update applied to the data set. In the case of an update cell file the file extension is the same as the update number.
update application (date)	this date is only used for the base cell files (i.e. new data sets, re-issue and new edition), not update cell files. All updates dated on or before this date must have been applied by the producer.
issue date	date on which the data was made available by the data producer.

Table 1-1 gives examples of the way to manage the file extension, the “Edition Number” [EDTN], the “Update Number” [UPDN], the “Update Application Date” [UADT] and the “Issue Date” [ISDT] subfields.

Table 1-1
File extension examples

Event	File extension	EDTN	UPDN	UADT	ISDT
New data set	.000	1	0	19950104	19950104
Update 1	.001	1	1	prohibited	19950121
Update 2	.002	1	2	prohibited	19950225
...					
Update 31	.031	1	31	prohibited	19950905
Re-issue of a data set	.000	1	31	19950905	19950910
Update 32	.032	1	32	prohibited	19951023
...					
Update 45	.045	1	45	prohibited	19951112
New edition	.000	2	0	19951201	19951201
Update 1 to edition 2	.001	2	1	prohibited	19960429
...					

This example table relates to the specifications given in REF#IHO-S52 App 1, “*Guidance on Updating the Electronic Navigational Chart*”, in the following way:

- The update information encoded in each individual cell file is called a sequential update.
- The collection of the update information encoded in the update cell files which have been issued since the last new data set, the last re-issue of a data set or since the last update was applied to the SENC is called a cumulative update. In the example, the cumulative update for the new data set starts with update number 1. The cumulative update for the re-issue of a data set starts with update number 32. The cumulative update for a data set to which update number n has been applied starts with update number n+1.
- The update information which has been incorporated in a re-issue of a data set is called a compilation update.

Each re-issue or new edition of a data set must have the same name as the base cell file which it replaces.

The update mechanism is described in REF#IHO-S57 Part 3, clause 8.

In order to delete a data set, an update cell file is created, containing only the Data Set General Information record with the "Data Set Identifier" [DSID] field. The "Edition Number" [EDTN] subfield must be set to 0. This message is only used to cancel a base cell file.

To inform the boatmaster that a new edition is available, an update cell file is created, containing only the Data Set General Information record with the "Data Set Identifier" [DSID] field. The "Edition Number" [EDTN] subfield must contain a value one higher than the current edition number.

In order to modify a text, picture or application file, a new file with the same name is created.

When an feature pointing to a text, picture or application file is deleted or updated so that it no longer references the file, the ECDIS software should check to see whether any other feature reference the same file, before that file is deleted.

An exchange set may contain base cell files and update cell files for the same cells. Under these circumstances the update cell files must follow on in the correct sequential order from the last update applied to the base cell file.

The record version of each feature or vector record is indicated in the "Record Version" [RVER] subfield of the "Feature Record Identifier" [FRID] field or the "Vector Record Identifier" [VRID] field. At each update of a record, this version number is incremented by 1.

5.8 Media

Data must be made available on CD-ROM. It may also be made available on any other physical media by private arrangement.

Data may be provided via telecommunication links.

5.9 Error detection

File integrity checks are based on the CRC-32 algorithm (a 32 bit Cyclic Redundancy Check algorithm) as defined in ANSI/IEEE Standard 802.3 (=IEEE Standards for Local Area Networks, Carrier Sense Multiple Access with Collision Detection (CSMA/CD) Access Method and Physical Layer Specifications).

5.9.1 Implementation

The checksums for each data set are held in the "CRC" [CRCS] subfield of the "Catalogue Directory" [CATD] field. They allow the integrity of each file in the exchange set to be checked on receipt. The CRC value computed on the received file must be the same as the CRC value transmitted.

The CRC values are recorded in ASCII as a hexadecimal number least significant byte first.

5.9.2 Processing

Encoding is defined by the following generating polynomial:

$$G(x) = x^{32} + x^{26} + x^{23} + x^{22} + x^{16} + x^{12} + x^{11} + x^{10} + x^8 + x^7 + x^5 + x^4 + x^2 + x + 1$$

Processing is applied to relevant files as they appear in the exchange set.

The CRC value of the file is defined by the following process:

1. The first 32 bits of the data are complemented.
2. The n bits of the data are then considered to be the coefficients of a polynomial M(x) of degree n-1.
3. M(x) is multiplied by x^{32} and divided by G(x), producing a remainder R(x) of degree <31.
4. The coefficients of R(x) are considered to be a 32-bit sequence.
5. The bit sequence is complemented and the result is the CRC.

The hexadecimal format of CRCs is converted to ASCII characters and stored in the "Catalogue Directory" [CATD] field.

An example of coding in C language is given in Annex B of REF#IHO-S57.

6. Application profiles

6.1 General

The application profiles define the structure and content of the catalogue file and data set file in an exchange set.

6.1.1 Catalogue and data set files

These files are composed of the records and fields defined in the following tree structure diagrams (see paragraph 6.2.1, 6.3.1 and 6.4.1).

The order of data in each base or update cell file is described below:

Data set file

Data set general information record

(Data set) geographic reference record (for EN application profile)

Vector records

Isolated nodes (SG3D)

Isolated nodes (SG2D)

Connected nodes

Edges

Feature records

Meta features

Geo features (ordered from slave to master)

Collection features

This order of records will enable the import software to check that the child record exists each time the parent record references it (i.e. it will already have read the child record so it will know if it exists or not).

6.1.2 Records

Records and fields that do not appear in the following tree structure diagrams are prohibited. The order of records in the files must be the same as that described in these tree structure diagrams.

The combination of the file name and the “Name” of the record must provide a unique worldwide identifier of the record.

6.1.3 Fields

For base cell files, some fields may be repeated (indicated by <R>) and all of their content may be repeated (indicated by *). In order to reduce the volume of data, the encoder should repeat the sequence of subfields, in preference to creating several fields.

6.1.4 Subfields

Mandatory subfields must be filled by a non-null value.

Prohibited subfields must be encoded as missing subfields values (see REF#IHO-S57 Part 3, clause 2.1).

The exact meaning of missing enumerations is defined in paragraph 3.5.1.

In the tables following the tree structure diagrams, mandatory subfields are shown by “M” in the “use” column and prohibited subfields by “P” in the same column. If there is nothing in this column, it means that the use of this subfield is optional. When a subfield value is prescribed, it is indicated in the “value” column. The “comment” column contains general comments and an indication of whether the subfield is ASCII or binary coded.

6.2 Catalogue file

The catalogue has the same structure for EN and ER application profiles.

6.2.1 Catalogue file structure

Catalogue file

```

|
|--<R>-Catalogue Directory record
    |
    |--0001—REF#ISO-IEC-8211 Record identifier
        |
        |--<1>-- CATD - Catalogue Directory field
  
```

6.2.2 Catalogue Directory field - CATD

NB: All subfield values are encoded as ASCII.

Tag	subfield name	use	value	comment
RCNM	Record name	M	CD	
RCID	Record identification number	M		
FILE	File name	M		full path from ENC_ROOT directory
LFIL	File long name			
VOLM	Volume	M		name of volume on which file appears
IMPL	Implementation	M	ASC BIN TXT TIF ...	for the catalogue file for the data set files for ASCII text files (including the README.TXT file) for picture files or any other usual file extension for file provided through private agreements (see paragraph 5.6.4)
SLAT	Southernmost latitude			mandatory for data set files
WLON	Westernmost longitude			mandatory for data set files
NLAT	Northernmost latitude			mandatory for data set files
ELON	Easternmost longitude			mandatory for data set files
CRCS	CRC	M		except for README and catalogue files
COMT	Comment			

6.3 EN application profile

The EN application profile applies to any base cell file (i.e. new data set, re-issue and new edition of a data set).

6.3.1 Base cell file structure

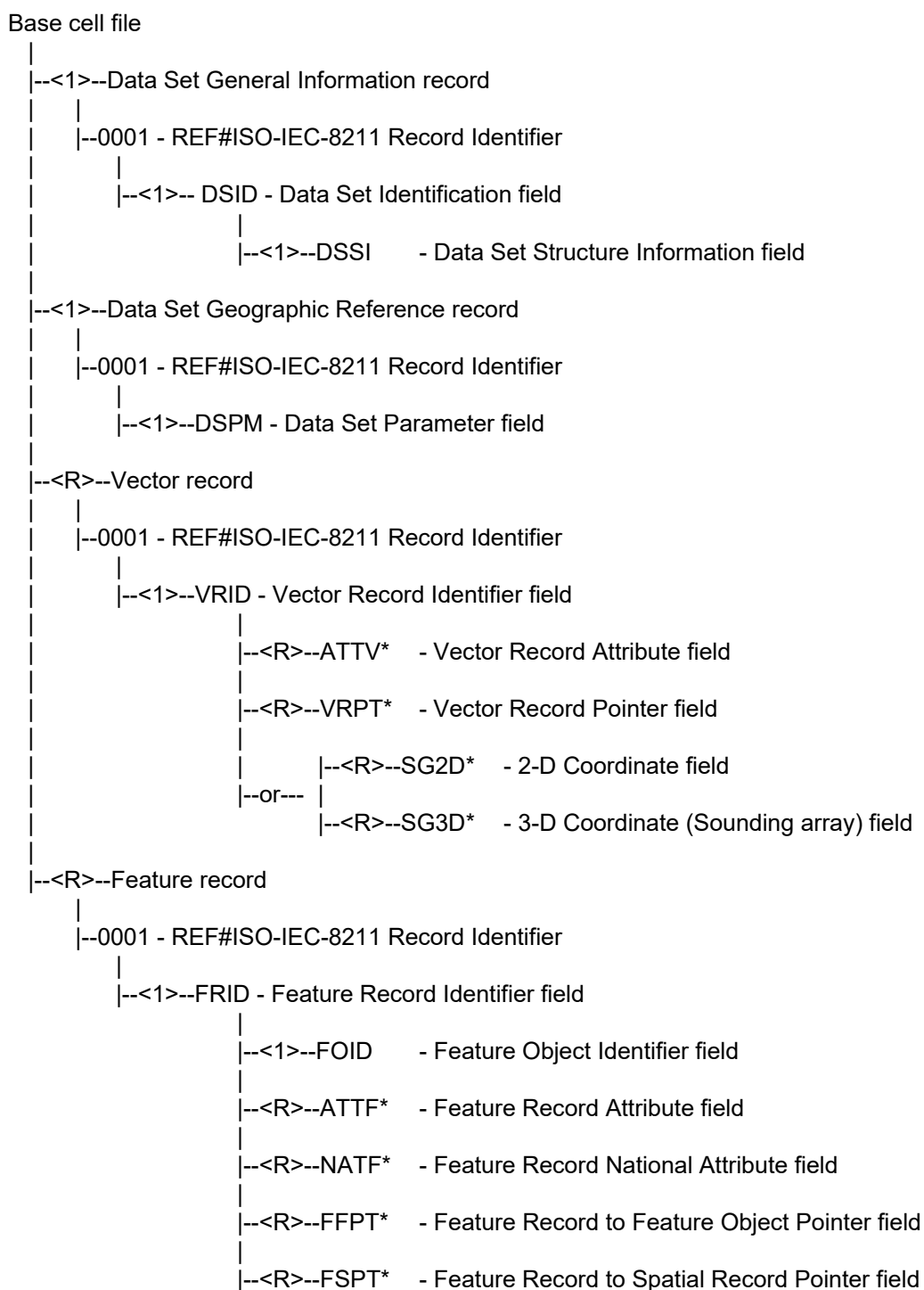

6.3.2 Field content (EN)

6.3.2.1 Data set identification field - DSID

NB: Subfield values are encoded as ASCII or binary as indicated.

IENCs are considered as an independent product besides ENC. To recognise a REF#IHO-S57 dataset as an IENC the content of the subfields PRSP and PRED differs from REF#IHO-S57.

Tag	subfield name	use	value	comment
RCNM	Record name	M	{10}	= DS, binary
RCID	Record identification number	M		Binary
EXPP	Exchange purpose	M	{1}	Data set is new, binary
INTU	Intended usage	M	{1} to {9}, {A}	Navigational purpose, see paragraph 2.1 and 5.6.3, binary
DSNM	Data set name	M		File name with extension excluding path, ASCII
EDTN	Edition number	M		See paragraph 5.7, ASCII
UPDN	Update number	M		ASCII
UADT	Update application date	M		ASCII
ISDT	Issue date	M		ASCII
STED	Edition number of REF#IHO-S57	M	03.1	ASCII
PRSP	Product Specification	M	{10}	= IENC, binary
PSDN	Product specification description	P		Empty, ASCII
PRED	Product Specification Edition Number	M	2.5	=ASCII
PROF	Application profile identification	M	{1}	= EN, binary
AGEN	Producing agency	M		Binary
COMT	Comment			ASCII

6.3.2.2 Data Set Structure Information field – DSSI

NB: All subfield values are encoded as binary.

Tag	subfield name	use	Value	comment
DSTR	Data structure	M	{2}	= chain node
AALL	ATTF lexical level	M	{0} or {1}	
NALL	NATF lexical level	M	{0}, {1} or {2}	
NOMR	Number of meta records	M		
NOCR	Number of cartographic records	M	{0}	cartographic records are not permitted
NOGR	Number of geo records	M		
NOLR	Number of collection records	M		
NOIN	Number of isolated node records	M		

Tag	subfield name	use	Value	comment
NOCN	Number of connected node records	M		
NOED	Number of edge records	M		
NOFA	Number of face records	M	{0}	faces are not permitted in chain node structure

6.3.2.3 Data Set Parameter field - DSPM

NB : Subfield values are encoded as ASCII or binary as indicated.

Tag	subfield name	use	Value	comment
RCNM	Record name	M	{20}	= DP, binary
RCID	Record identification number	M		binary
HDAT	Horizontal geodetic datum	M	{2}	= WGS 84, binary
VDAT	Vertical datum	M		binary
SDAT	Sounding datum	M		binary
CSCL	Compilation scale of data	M		binary
DUNI	Units of depth measurement	M	{1}	= metres, binary
HUNI	Units of height measurement	M	{1}	= metres, binary
PUNI	Units of positional accuracy	M	{1}	= metres, binary
COUN	Coordinate units	M	{1}	= lat/long, binary
COMF	Coordinate multiplication factor	M		binary, see paragraph 4.4
SOMF	3-D (sounding) multiplication factor	M	{10}	binary, see paragraph 4.4
COMT	Comment			ASCII

6.3.2.4 Vector Record Identifier field - VRID

NB: All subfield values are encoded as binary.

Tag	subfield name	use	value	Comment
RCNM	Record name	M	{110} or {120} or {130}	= VI, isolated node = VC, connected node = VE, edge
RCID	Record identification number	M		
RVER	Record version	M		
RUIN	Record update instruction	M	{1}	= insert

6.3.2.5 Vector Record Attribute field - ATTV

NB: Subfield values are encoded as ASCII or binary as indicated.

Tag	subfield name	use	value	comment
ATTL	Attribute label/code	M		binary code for an attribute
ATVL	Enumeration	M		ASCII value. Missing enumeration = attribute is relevant but value is unknown.

6.3.2.6 Vector Record Pointer field - VRPT

NB: All subfield values are encoded as binary.

Tag	subfield name	use	value	comment
NAME	Name	M		
ORNT	Orientation	M	{255}	= null
USAG	Usage indicator	M	{255}	= null
TOPI	Topology indicator	M	{1} or {2}	= beginning node = end node
MASK	Masking indicator	M	{255}	= null

6.3.2.7 2-D Coordinate field - SG2D

NB: All subfield values are encoded as binary.

Tag	subfield name	use	value	comment
YCOO	Coordinate in Y axis	M		latitude (see paragraph 4.4)
XCOO	Coordinate in X axis	M		longitude (see paragraph 4.4)

6.3.2.8 3-D Coordinate (Sounding array) field - SG3D

NB: All subfield values are encoded as binary.

Tag	subfield name	use	value	comment
YCOO	Coordinate in Y axis	M		latitude (see paragraph 4.4)
XCOO	Coordinate in X axis	M		longitude (see paragraph 4.4)
VE3D	3-D (sounding) value	M		value of sounding (see paragraph 4.4)

6.3.2.9 Feature Record Identifier field - FRID

NB: All subfield values are encoded as binary.

Tag	subfield name	use	value	comment
RCNM	Record name	M	{100}	= FE
RCID	Record identification number	M		
PRIM	Feature geometric primitive	M	{1} or {2} or {3} or {255}	= point = line = area = no geometry
GRUP	Group	M	{1} or {2}	Group 1, see paragraph 3.10.1 Group 2, see paragraph 3.10.2
OBJL	Feature label	M		binary code for a feature class
RVER	Record version	M		
RUIN	Record update instruction	M	{1}	= insert

6.3.2.10 Feature Object Identifier field - FOID

NB: All subfield values are encoded as binary.

Tag	subfield name	use	value	comment
AGEN	Producing agency	M		
FIND	Feature identification number	M		
FIDS	Feature identification subdivision	M		

6.3.2.11 Feature Record Attribute field - ATTF

NB: Subfield values are encoded as ASCII or binary as indicated.

Tag	subfield name	use	value	comment
ATTL	Attribute label/code	M		binary code for an attribute
ATVL	Enumeration			ASCII value. Missing enumeration = attribute is relevant but value is unknown.

6.3.2.12 Feature Record National Attribute field - NATF

NB: Subfield values are encoded as ASCII or binary as indicated.

Tag	subfield name	use	value	comment
ATTL	Attribute label/code	M		binary code for an attribute
ATVL	Enumeration			ASCII value. Missing enumeration = attribute is relevant but value is unknown

6.3.2.13 Feature Record to Feature Object Pointer field - FFPT

NB: Subfield values are encoded as ASCII or binary as indicated.

Tag	subfield name	use	value	comment
LNAM	Long name	M		binary
RIND	Relationship indicator	M	{2} or {3}	= slave, binary = peer, binary
COMT	Comment			ASCII

6.3.2.14 Feature Record to Spatial Record Pointer field - FSPT

NB: All subfield values are encoded as binary.

Tag	subfield name	use	value	comment
NAME	Name	M		
ORNT	Orientation	M	{1} or {2} or {255}	= forward = reverse = null
USAG	Usage indicator	M	{1} or {2} or {3} or {255}	= exterior = interior = exterior boundary, truncated by the data limit = null
MASK	Masking indicator	M	{1} or {2} or {255}	= mask = show = null

6.4 ER application profile

The ER application profile only applies to update cell files.

6.4.1 Update cell file structure

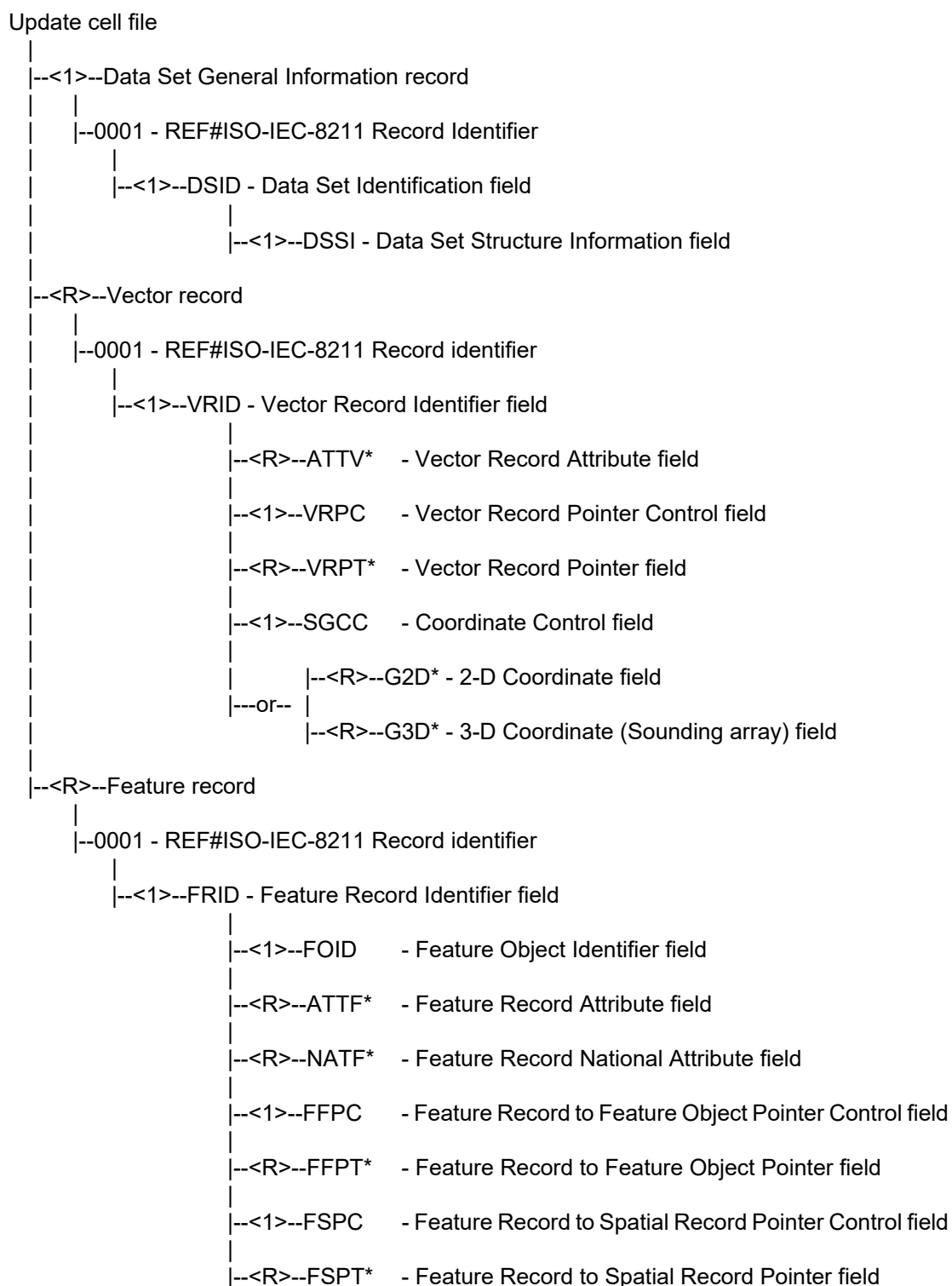

6.4.2 Field content (ER)

6.4.2.1 Data Set Identification Field - DSID

NB: Subfield values are encoded as ASCII or binary as indicated.

IENCs are considered as an independent product besides ENC. To recognise a REF#IHO-S57 dataset as an IENC the content of the subfields PRSP and PRED differs from REF#IHO-S57.

tag	subfield name	use	value	comment
RCNM	Record name	M	{10}	= DS, binary
RCID	Record identification number	M		Binary
EXPP	Exchange purpose	M	{2}	Data set is a revision, binary
INTU	Intended usage	M	{1} to {9}, {A}	Navigational purpose, see paragraph 2.1 and 5.6.3, binary
DSNM	Data set name	M		File name with extension excluding path, ASCII
EDTN	Edition number	M		See paragraph 5.7, ASCII
UPDN	Update number	M		ASCII
UADT	Update application date	M		ASCII
ISDT	Issue date	M		ASCII
STED	Edition number of REF#IHO-S57	M	03.1	ASCII
PRSP	Product Specification	M	{10}	= IENC, binary
PSDN	Product specification description	P		Empty, ASCII
PRED	Product Specification Edition Number	M	2.5	= ASCII
PROF	Application profile identification	M	{2}	= ER, binary
AGEN	Producing agency	M		Binary
COMT	Comment			ASCII

6.4.2.2 Data Set Structure Information field – DSSI

NB: All subfield values are encoded as binary.

Tag	subfield name	use	value	comment
DSTR	Data structure	M	{2}	= chain node
AALL	ATTF lexical level	M	{0} or {1}	
NALL	NATF lexical level	M	{0} or {1} or {2}	
NOMR	Number of meta records	M		
NOCR	Number of cartographic records	M	{0}	cartographic records are not permitted
NOGR	Number of geo records	M		
NOLR	Number of collection records	M		
NOIN	Number of isolated node records	M		
NOCN	Number of connected node records	M		
NOED	Number of edge records	M		
NOFA	Number of face records	M	{0}	faces are not permitted in chain node structure

6.4.2.3 Vector Record Identifier field - VRID

NB: All subfield values are encoded as binary.

Tag	subfield name	use	value	comment
RCNM	Record name	M	{110} or {120} or {130}	= VI, isolated node = VC, connected node = VE, edge
RCID	Record identification number	M		
RVER	Record version	M		
RUIN	Record update instruction	M	{1} or {2} or {3}	= insert = delete = modify

6.4.2.4 Vector Attribute field - ATTV

NB: Subfield values are encoded as ASCII or binary as indicated.

Tag	subfield name	use	value	comment
ATTL	Attribute label/code	M		binary code for an attribute
ATVL	Enumeration			ASCII value, missing enumeration = enumeration is deleted or unknown (see paragraph 3.5.1)

6.4.2.5 Vector Record Pointer Control field - VRPC

NB: All subfield values are encoded as binary.

Tag	subfield name	use	value	comment
VPUI	Vector record pointer update instruction	M	{1} or {2} or {3}	= insert = delete = modify
VPIX	Vector record pointer index	M		
NVPT	Number of vector record pointers	M		

6.4.2.6 Vector Record Pointer field - VRPT

NB: All subfield values are encoded as binary.

Tag	subfield name	use	value	comment
NAME	Name	M		
ORNT	Orientation	M	{255}	= null
USAG	Usage indicator	M	{255}	= null
TOPI	Topology indicator	M	{1} or {2}	= beginning node = end node
MASK	Masking indicator	M	{255}	= null

6.4.2.7 Coordinate Control field - SGCC

NB: All subfield values are encoded as binary.

Tag	subfield name	use	value	comment
CCUI	Coordinate update instruction	M	{1} or {2} or {3}	= insert = delete = modify
CCIX	Coordinate index	M		
CCNC	Number of coordinates	M		

6.4.2.8 2-D Coordinate field - SG2D

NB: All subfield values are encoded as binary.

Tag	subfield name	use	value	comment
YCOO	Coordinate in Y axis	M		latitude (see paragraph 4.4)
XCOO	Coordinate in X axis	M		longitude (see paragraph 4.4)

6.4.2.9 3-D Coordinate (Sounding array) field - SG3D

NB: All subfield values are encoded as binary.

Tag	subfield name	use	value	comment
YCOO	Coordinate in Y axis	M		latitude (see paragraph 4.4)
XCOO	Coordinate in X axis	M		longitude (see paragraph 4.4)
VE3D	3-D (sounding) value	M		value of sounding (see paragraph 4.4)

6.4.2.10 Feature Record Identifier field - FRID

NB: All subfield values are encoded as binary.

Tag	subfield name	use	value	comment
RCNM	Record name	M	{100}	= FE
RCID	Record identification number	M		
PRIM	Feature geometric primitive	M	{1} or {2} or {3} or {255}	= point = line = area = no geometry
GRUP	Group	M	{1} or {2}	Group 1, see paragraph 3.10.1 Group 2, see paragraph 3.10.2
OBJL	Feature label	M		binary code for a feature class
RVER	Record version	M		
RUIN	Record update instruction	M	{1} or {2} or {3}	= insert = delete = modify

6.4.2.11 Feature Object Identifier field - FOID

NB: All subfield values are encoded as binary.

Tag	subfield name	use	value	comment
AGEN	Producing agency	M		
FIND	Feature identification number	M		
FIDS	Feature identification subdivision	M		

6.4.2.12 Feature Record Attribute field - ATTF

NB: Subfield values are encoded as ASCII or binary as indicated.

Tag	subfield name	use	value	comment
ATTL	Attribute label/code	M		binary code for an attribute
ATVL	Enumeration			ASCII value. Missing enumeration = enumeration is deleted or unknown (see paragraph 3.5.1)

6.4.2.13 Feature Record National Attribute field - NATF

NB: Subfield values are encoded as ASCII or binary as indicated.

Tag	subfield name	use	value	Comment
ATTL	Attribute label/code	M		Binary code for an attribute
ATVL	Enumeration			ASCII value. Missing enumeration = enumeration is deleted.

6.4.2.14 Feature Record to Feature Object Pointer Control field - FFPC

NB: All subfield values are encoded as binary.

Tag	subfield name	use	value	Comment
FFUI	Feature object pointer update instruction	M	{1} or {2} or {3}	= insert = delete = modify
FFIX	Feature object pointer index	M		
NOPT	Number of feature object pointers	M		

6.4.2.15 Feature Record to Feature Object Pointer field - FFPT

NB: Subfield values are encoded as ASCII or binary as indicated.

Tag	subfield name	use	value	Comment
LNAM	Long name	M		Binary
RIND	Relationship indicator	M	{2} or {3}	= slave, binary = peer, binary
COMT	Comment			ASCII

6.4.2.16 Feature Record to Spatial Record Pointer Control field - FSPC

NB: All subfield values are encoded as binary.

Tag	subfield name	use	value	Comment
FSUI	Feature to spatial record pointer update instruction	M	{1} or {2} or {3}	= insert = delete = modify
FSIX	Feature to spatial record pointer index	M		
NSPT	Number of feature to spatial record pointers	M		

6.4.2.17 Feature Record to Spatial Record pointer field - FSPT

NB: All subfield values are encoded as binary.

Tag	subfield name	use	value	comment
NAME	name	M		
ORNT	orientation	M	{1} or {2} or {255}	= forward = reverse = null
USAG	usage indicator	M	{1} or {2} or {3} or {255}	= exterior = interior = exterior boundary, truncated by the data limit = null
MASK	Masking indicator	M	{1} or {2} or {255}	= mask = show = null

7. Maintenance

Every member of the IEHG is entitled to publish proposals for amendments or changes of this Product Specification for IENCs including:

- the IENC Feature Catalogue and
- the Encoding Guide for IENCs

on the IEHG discussion forum at <http://ienc.openecdis.org>. Each proposal has to contain an explanation, why the amendment or the change is needed.

Proposals for amendments of the IENC Feature Catalogue have to include a proposal for an amendment of the Encoding Guide for IENCs with regard to the use of these amendments.

The members of the Inland ECDIS Expert Group and the IEHG are requested to react as soon as possible. A veto against a proposal has to contain an explanation for the objection. If there is no veto within six weeks, the proposal is adopted. If there is a veto, there are the following possibilities to proceed:

- The party, which has transmitted the proposal, can decide to withdraw the proposal.
- If an updated proposal is transmitted, it is handled as a new proposal.
- If the party, which has transmitted the proposal, wants to keep up the original proposal without any changes, the proposal will be discussed and decided upon at the next meeting of the IEHG.

The members of the IEHG discussion forum, who have actively participated in the development of the Product Specification and its annexes within the twelve months before a meeting of the IEHG, are entitled to take part in this meeting.

Each new version of the Feature Catalogue for IENC results in a new version of the Product Specification for IENCs.

Appendix 1 IENC Feature Catalogue, Edition 2.5.1, 2021-04-21 (Distributed separately)

Appendix 2 Encoding Guide for IENCs, Edition 2.5.1, 2021-04-21 (Distributed separately)

ANNEX 2
PRESENTATION LIBRARY FOR IENCs, EDITION 2.5

TABLE OF CONTENTS

1.	LOOKUP TABLES	331
2.	CONDITIONAL SYMBOLOGY PROCEDURES (CS).....	331
2.1	TOP MARKS.....	331
2.2	DAYMARS	331
2.3	RESTRICTED AREAS.....	331
2.4	LIGHTS	331
2.5	BRIDGES.....	331
2.6	NOTICE MARKS.....	333
2.7	M_COVR.....	333
2.8	ANCHORAGE AREAS, DEPTH AREAS, EXCEPTIONAL NAVIGATIONAL STRUCTURES, SHORELINE CONSTRUCTIONS AND UNDERWATER ROCKS.....	333
3.	SYMBOLS FOR INLAND ECDIS	333
4.	LIST OF SYMBOL NAMES	334
4.1	NEW SYMBOLS TO BE SHOWN ON THE CHART DISPLAY.....	334
4.1.1	<i>Raster symbols</i>	<i>334</i>
4.1.2	<i>Vector symbols for European inland waterways (must be rotated)</i>	<i>338</i>
4.2	NEW SYMBOLS TO BE SHOWN IN THE "INFORMATION WINDOW ON NOTICE MARKS"	338
4.2.1	<i>Notice marks for European inland waterways</i>	<i>338</i>
4.2.2	<i>Notice marks for Russian inland waterways (the numbers refer to GOST 26600-98).....</i>	<i>342</i>
4.2.3	<i>Auxiliary panels.....</i>	<i>343</i>
5.	PICTURES OF INLAND ECDIS SYMBOLS	344
5.1	RASTER SYMBOLS	344
5.1.1	<i>Symbols in general</i>	<i>344</i>
5.1.2	<i>Navigational aids.....</i>	<i>345</i>
5.1.3	<i>Harbour facilities, terminals</i>	<i>348</i>
5.2	SYMBOLS FOR THE "INFORMATION WINDOW ON NOTICE MARKS"	349
5.3	VECTOR SYMBOLS.....	352
6.	BATHYMETRIC IENCs	352

1. Lookup Tables

The up-to-date Look-up Tables for areas, lines and points are published at <https://ienc.openecdis.org>.

2. Conditional Symbology Procedures (CS)

2.1 Top marks

The CS (TOPMAR01) of REF#IHO-S52 has to be modified because in this CS it is checked on which structure the top mark is fixed. Since the ENC feature BOYLAT was copied, in the CS the feature boylat has to be added to the list of floating structures. If the top mark is located on a boylat the symbols TOPMA1* have to be drawn according to the top shape and colour.

2.2 Daymars

A new CS DAYMAR01 has to be introduced. This CS is similar to the CS TOPMAR01 (see paragraph 2.1) with the exception that there is no need for the distinction of floating and fixed structures, because daymarks exists only for beacons, i.e. fixed structures.

2.3 Restricted areas

Since the ENC feature RESARE and the attribute RESTRN were copied the CS (RESARE03) of REF#IHO-S52 has to be modified because in this CS the values of the attribute RESTRN are checked. That means that in the case that RESTRN is not given it has to be checked for the copied attribute restrn instead.

2.4 Lights

The CS for LIGHTS (LIGHTS05) of REF#IHO-S52 is affected because in this CS there is a check whether a light is located on a floating object or on a fixed object. The list of floating platforms must be extended by the new feature "boylat". To avoid a copy of this CS which would lead to a copy of the official feature LIGHTS, the Inland ECDIS manufacturers have to extend the official CS for LIGHTS as described above.

2.5 Bridges

A new CS for bridges has to be introduced to be able to indicate for bridge arches

- a) the maximum vertical clearance depending on the given beam,
- b) the available space depending on the given beam and air draft.

The condition for this is the encoding of a bridge arch as it is described in the Annex 1, Appendix 2.

The Inland ECDIS manufacturers have to calculate the vertical clearance of aggregated bridge objects according to the given beam of the ship.

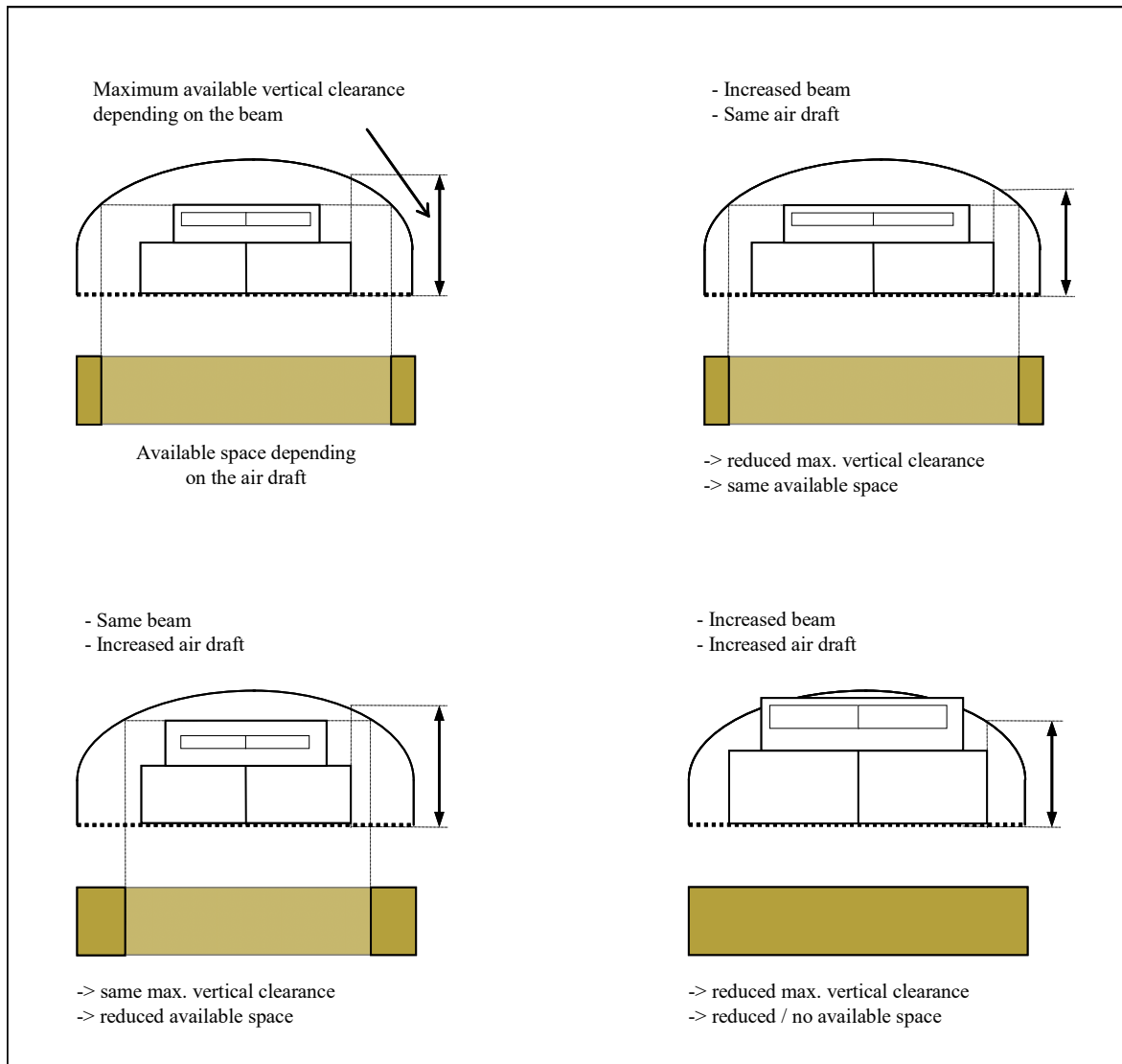

If the vertical clearance of a single bridge object of the aggregation is less than the calculated vertical clearance, this single bridge object must be symbolized by the symbol instruction "AC(CHBRN,3);TX('clr %.1f',1,2,3,'14108',1,1,CHBLK,11)"

If the vertical clearance of a single bridge object of the aggregation is larger or equal than the calculated vertical clearance, this single bridge object must be symbolized by the symbol instruction "AC(CHBRN,2)" without the indication of the non sufficient vertical clearance.

The boundaries of the bridge sequences which are not safe for navigation must be symbolized with the symbol instruction "LS(SOLD,2,DEPSC)".

The boundaries of the bridge sequences which are safe for navigation must be symbolized with the symbol instruction "LS(SOLD,1,CHGRD)".

The boundaries of the single bridge objects inside a bridge sequence, either safe or not safe for navigation, may not be symbolized.

2.6 Notice marks

A new CS has to be introduced for notice marks. If there are several notice marks at the same point the `fnctnm` attributes have to be evaluated for the selection of the correct symbol:

- if there is at least one notice mark with `fnctnm = 1` (prohibition mark), the symbol `notmrk04` has to be used;
- if there is no prohibition mark, but at least one notice mark with `fnctnm = 2` (regulation mark) or `fnctnm = 3` (restriction mark), the symbol `notmrk05` has to be used;
- if there are only notice marks with `fnctnm = 4` (recommendation mark) and/or notice marks with `fnctnm = 5` (information mark), the symbol `notmrk06` has to be used.

The symbols `NMKREG21`, `NMKREG22`, `NMKREG23`, `NMKREG24`, `NMKRCD07`, `NMKRCD08`, and `NMKINF60` shall only be used if the attribute `ORIENT` is encoded and only for an optional display of detailed notice mark symbols. If `ORIENT` is not encoded, the symbols `NMKREG02`, `NMKREG03`, `NMKREG10`, `NMKREG11`, `NMKRCD05`, `NMKRCD06`, and `NMKINF38` have to be used.

2.7 M_COVR

The CS (`DATCVR02`) of `REF#IHO-S52` has to be modified for the display of bathymetric IENCs. The `M_COVR` object of the `blENC` shall be displayed with a blue outline for a clear distinction between areas which are covered by `blENCs` and areas which are not.

2.8 Anchorage areas, depth areas, exceptional navigational structures, shoreline constructions and underwater rocks

The CS procedures for

- anchorage areas (`RESTRN01`),
- depth areas and exceptional navigational structures (`DEPARE02`),
- shoreline constructions (`SLCONS04`) and
- underwater rocks (`OBSTRN07`)

of `REF#IHO-S52` have to be modified to include the display of `achare`, `depare`, `excnst`, `slcons` and `uwtrc`.

3. Symbols for Inland ECDIS

Symbols can be defined in vector format or in raster format. Symbols which will be rotated must be defined in vector format. The size of vector symbols is adapted automatically to the resolution and size of the screen. In case of raster symbols, different symbol sets must be designed to meet the requirements of a readable display.

A list of all Inland ECDIS symbols and their pictures is in Chapter 4 and 5. The symbols are supplied in digital form at <https://ienc.openecdis.org>.

4. List of symbol names

4.1 New Symbols to be shown on the chart display

4.1.1 Raster symbols

4.1.1.1 Symbols in general

BORDER01:	check point, border
BUNSTA01:	bunker station, diesel fuel station
BUNSTA02:	bunker station, water
BUNSTA03:	bunker station, ballast
BUNSTA04:	power supply
CUSTOM01:	control point, custom
DISMAR05:	distance mark on river axis
HECMTR01:	hectometre point, 100 m
HECMTR02:	hectometre point, 1 km
HGWTMK01:	high water mark
LIFEBUOY:	rescue station with life buoy, ring buoy, life ring or life saver
NOTMRK01:	notice mark, prohibition
NOTMRK02:	notice mark, regulation, restriction
NOTMRK03:	notice mark, information, recommendation
NOTMRK04:	several notice marks, at least one prohibition mark
NOTMRK05:	several notice marks, no prohibition mark, at least one regulation or restriction mark
NOTMRK06:	several notice marks, only information and/or recommendation marks
REFDMP01:	refuse dump
SSEINTR01:	port entry
SSLOCK01:	signal station, lock
SSWARS01:	signal station, Wahrschau
TRNBSN01:	turning basin
VEHTRF01:	vehicle transfer
VTCLMK01:	vertical clearance mark at bridges
WTLVGG02:	gauge, height of water

4.1.1.2 Navigational aids

BCNSTK03:	river beacon, stake – pole
BCNLAT23:	river beacon, separation - simplified

BOYLAT25:	river buoy, fairway separation – simplified
BOYLAT26:	river buoy, obstruction at the right side
BOYLAT26O:	AIS river buoy, obstruction at the right side, on position
BOYLAT26V:	AIS virtual river buoy, obstruction at the right side
BOYLAT26M:	AIS river buoy, obstruction at the right side, missing
BOYLAT26F:	AIS river buoy, obstruction at the right side, off position
BOYLAT27:	river buoy, obstruction at the left side
BOYLAT27O:	AIS river buoy, obstruction at the left side, on position
BOYLAT27V:	AIS virtual river buoy, obstruction at the left side
BOYLAT27M:	AIS river buoy, obstruction at the left side, missing
BOYLAT27F:	AIS river buoy, obstruction at the left side, off position
BOYINL01:	river buoy right-hand side of the fairway
BOYINL01O:	AIS river buoy right-hand side of the fairway, on position
BOYINL01V:	AIS virtual river buoy right-hand side of the fairway
BOYINL01M:	AIS river buoy right-hand side of the fairway, missing
BOYINL01F:	AIS river buoy right-hand side of the fairway, off position
BOYINL02:	river buoy left-hand side of the fairway
BOYINL02O:	AIS river buoy left-hand side of the fairway, on position
BOYINL02V:	AIS virtual river buoy left-hand side of the fairway
BOYINL02M:	AIS river buoy left-hand side of the fairway, missing
BOYINL02F:	AIS river buoy left-hand side of the fairway, off position
BOYINL03:	river buoy bifurcation of the fairway
BOYINL03O:	AIS river buoy bifurcation of the fairway, on position
BOYINL03V:	AIS virtual river buoy bifurcation of the fairway
BOYINL03M:	AIS river buoy bifurcation of the fairway, missing
BOYINL03F:	AIS river buoy bifurcation of the fairway, off position
BOYINL08:	river buoy yellow float
BOYINL08O:	AIS river buoy yellow float, on position
BOYINL08V:	AIS virtual river buoy yellow float
BOYINL08M:	AIS river buoy yellow float, missing
BOYINL08F:	AIS river buoy yellow float, off position
DFND01O:	buoys marking berthing areas on the right-hand side of the fairway, on position
DFND01M:	buoys marking berthing areas on the right-hand side of the fairway, missing
DFND01F:	buoys marking berthing areas on the right-hand side of the fairway, off position

DFND02O:	buoys marking berthing areas on the left-hand side of the fairway, on position
DFND02M:	buoys marking berthing areas on the left-hand side of the fairway, missing
DFND02F:	buoys marking berthing areas on the left-hand side of the fairway, off position
TOPMA100:	beacon top mark, red cone, point down
TOPMA101:	beacon top mark, red boarded cone, point down
TOPMA102:	beacon top mark, green cone, point up
TOPMA103:	beacon top mark, green boarded cone, point up
TOPMA104:	beacon top mark, red boarded cone, point down, green boarded cone, point up, simplified
TOPMA105:	beacon top mark, red boarded cone, point down, green boarded cone, point up, simplified
TOPMA106:	beacon top mark, white-red square board, vertical
TOPMA106O:	AIS beacon top mark, white-red square board, vertical, on position
TOPMA106V:	AIS virtual beacon top mark, white-red square board, vertical
TOPMA106M:	AIS beacon top mark, white-red square board, vertical, missing
TOPMA106F:	AIS beacon top mark, white-red square board, vertical, off position
TOPMA107:	beacon top mark, red boarded square board, vertical
TOPMA107O:	AIS beacon top mark, red boarded square board, vertical, on position
TOPMA107V:	AIS virtual beacon top mark, red boarded square board, vertical
TOPMA107M:	AIS beacon top mark, red boarded square board, vertical, missing
TOPMA107F:	AIS beacon top mark, red boarded square board, vertical, off position
TOPMA108:	beacon top mark, white-green square board, diagonal
TOPMA108O:	AIS beacon top mark, white-green square board, diagonal, on position
TOPMA108V:	AIS virtual beacon top mark, white-green square board, diagonal
TOPMA108M:	AIS beacon top mark, white-green square board, diagonal, missing
TOPMA108F:	AIS beacon top mark, white-green square board, diagonal, off position

TOPMA109:	beacon top mark, green boarded square board, diagonal
TOPMA109O:	AIS beacon top mark, green boarded square board, diagonal, on position
TOPMA109V:	AIS virtual beacon top mark, green boarded square board, diagonal
TOPMA109M:	AIS beacon top mark, green boarded square board, diagonal, missing
TOPMA109F:	AIS beacon top mark, green boarded square board, diagonal, off position
TOPMA110:	beacon top mark, yellow-black square board, vertical
TOPMA110O:	AIS beacon top mark, yellow-black square board, vertical, on position
TOPMA110V:	AIS virtual beacon top mark, yellow-black square board, vertical
TOPMA110M:	AIS beacon top mark, yellow-black square board, vertical, missing
TOPMA110F:	AIS beacon top mark, yellow-black square board, vertical, off position
TOPMA111:	beacon top mark, yellow St. Georg cross
TOPMA112:	beacon top mark, yellow-black square board, diagonal
TOPMA112O:	AIS beacon top mark, yellow-black square board, diagonal, on position
TOPMA112V:	AIS virtual beacon top mark, yellow-black square board, diagonal
TOPMA112M:	AIS beacon top mark, yellow-black square board, diagonal, missing
TOPMA112F:	AIS beacon top mark, yellow-black square board, diagonal, off position
TOPMA113:	beacon top mark, yellow Andreas-cross
TOPMA114:	buoy top mark, red cylinder
TOPMA115:	buoy top mark, green cone, point up
TOPMA116:	buoy top mark, red-white-red board, entry prohibited
TOPMA117:	buoy top mark, red-green sphere
SIGFLT01O:	signal float, on position
SIGFLT01M:	signal float, missing
SIGFLT01F:	signal float, off position

4.1.1.3 Harbour facilities and terminals

HRBFAC10:	default harbour facility
HRBFAC11:	harbour facility naval base
HRBFAC12:	harbour facility ship yard
HRBFAC13:	harbour facility harbour-master's office

HRBFAC14:	harbour facility pilot
HRBFAC15:	water police
HRBFAC16:	customs office
HRBFAC17:	harbour facility service and repair
HRBFAC18:	harbour facility quarantine station
TERMNL01:	terminal, passenger terminal
TERMNL02:	terminal, ferry terminal
TERMNL03:	terminal, Container trans-shipment
TERMNL04:	terminal, Bulk trans-shipment
TERMNL05:	terminal, Oil trans-shipment
TERMNL06:	terminal, Fuel trans-shipment
TERMNL07:	terminal, Chemical trans-shipment
TERMNL08:	terminal, Liquid Goods trans-shipment
TERMNL09:	terminal, Explosive goods trans-shipment
TERMNL10:	terminal, Fish trans-shipment
TERMNL11:	terminal, Car trans-shipment
TERMNL12:	terminal, General Cargo transshipment
TERMNL13:	terminal, RoRo Terminal

4.1.2 Vector symbols for European inland waterways (must be rotated)

NMKPRH02:	no entry (general sign)
NMKPRH12:	no passing on left side
NMKPRH13:	no passing on right side
NMKRCD01:	recommended channel in both directions
NMKRCD02:	recommended channel only in the direction indicated
NMKRCD03:	you are recommended to keep on right side
NMKRCD04:	you are recommended to keep on left side
NMKINF01:	entry permitted
NMKREG50:	wreck pontoon, passage allowed on side showing red-white sign
NMKREG51:	wreck pontoon, passage allowed on both sides

4.2 New symbols to be shown in the "information window on notice marks"

4.2.1 Notice marks for European inland waterways

NMKPRH03:	sections closed to use, no entry except for non-motorized small craft
NMKPRH04:	no overtaking
NMKPRH05:	no overtaking of convoys by convoys

NMKPRH06:	no passing or overtaking
NMKPRH07:	no berthing (i.e. no anchoring or making fast to the bank) on the side of the waterway on which the sign is placed
NMKPRH08:	no anchoring or trailing of anchors, cables or chains on the side of the waterway on which the sign is placed
NMKPRH09:	no making fast to the bank on the side of the waterway on which the sign is placed
NMKPRH10:	no turning
NMKPRH11:	do not create wash likely to cause damage
NMKPRH14:	motorized craft prohibited
NMKPRH15:	sports or pleasure craft prohibited
NMKPRH16:	water skiing prohibited
NMKPRH17:	sailing vessels prohibited
NMKPRH18:	all craft other than motorized vessels or sailing craft prohibited
NMKPRH19:	use of sail boards prohibited
NMKPRH20:	water bikes prohibited
NMKPRH21:	end of zone authorized for high speed navigation of small sport and pleasure craft
NMKPRH22:	no launching or beaching of vessels
NMKREG01:	there are restrictions on navigation: make enquiries (with additional sign at bottom of main sign)
NMKREG02:	proceed in left direction
NMKREG03:	proceed in right direction
NMKREG04:	move to the side of the fairway on your port side
NMKREG05:	move to the side of the fairway on your starboard side
NMKREG06:	keep the side of the fairway on your port side
NMKREG07:	keep the side of the fairway on your starboard side
NMKREG08:	cross fairway to port
NMKREG09:	cross fairway to starboard
NMKREG10:	stop as prescribed in the regulations
NMKREG11:	give a sound signal
NMKREG12:	keep a particularly sharp outlook
NMKREG13:	do not enter the main waterway until certain that this will not oblige vessels proceeding on it to change their course or speed

NMKREG14:	do not cross the main waterway until certain that this will not oblige vessels proceeding on it to change their course or speed
NMKREG15:	obligation to enter in a radiotelephone link on the channel as indicated on the board
NMKREG16:	depth of water limited
NMKREG17:	headroom limited
NMKREG18:	width of passage or channel limited
NMKREG19:	the channel lies at a distance from the left bank
NMKREG20:	the channel lies at a distance from the right bank
NMKREG21:	proceed in left direction, orientation encoded
NMKREG22:	proceed in right direction, orientation encoded
NMKREG23:	stop as prescribed in the regulations, orientation encoded
NMKREG24:	give a sound signal, orientation encoded
NMKREG25:	obligation to use onshore power supply point
NMKRCD05:	you are recommended to proceed in the left direction
NMKRCD06:	you are recommended to proceed in the right direction
NMKRCD07:	you are recommended to proceed in the left direction, orientation encoded
NMKRCD08:	you are recommended to proceed in the right direction, orientation encoded
NMKINF02:	overhead cable crossing
NMKINF03:	weir
NMKINF04:	ferry-boat not moving independently
NMKINF05:	ferry-boat moving independently
NMKINF06:	berthing (i.e. anchoring or making fast to the bank) permitted on the side of the waterway on which the sign is placed
NMKINF07:	berthing area reserved for pushing navigation vessels that are not required to carry blue lights or blue cones on the side of the waterway on which the sign is placed
NMKINF08:	berthing area reserved for pushing navigation vessels that are required to carry one blue light or one blue cone on the side of the waterway on which the sign is placed
NMKINF09:	berthing area reserved for pushing navigation vessels that are required to carry two blue lights or two blue cones on the side of the waterway on which the sign is placed
NMKINF10:	berthing area reserved for pushing navigation vessels that are required to carry three blue lights or three blue cones on the side of the waterway on which the sign is placed
NMKINF11:	berthing area reserved for vessels other than pushing navigation vessels that are not required to carry blue lights or blue cones on the side of the waterway on which the sign is placed

NMKINF12:	berthing area reserved for vessels other than pushing navigation vessels that are required to carry one blue light or one blue cone on the side of the waterway on which the sign is placed
NMKINF13:	berthing area reserved for vessels other than pushing navigation vessels that are required to carry two blue lights or two blue cones on the side of the waterway on which the sign is placed
NMKINF14:	berthing area reserved for vessels other than pushing navigation vessels that are required to carry three blue lights or three blue cones on the side of the waterway on which the sign is placed
NMKINF15:	berthing area reserved for all vessels that are not required to carry blue lights or blue cones on the side of the waterway on which the sign is placed
NMKINF16:	berthing area reserved for all vessels that are required to carry one blue light or one blue cone on the side of the waterway on which the sign is placed
NMKINF17:	berthing area reserved for all vessels that are required to carry two blue lights or two blue cones on the side of the waterway on which the sign is placed
NMKINF18:	berthing area reserved for all vessels that are required to carry three blue lights or three blue cones on the side of the waterway on which the sign is placed
NMKINF19:	anchoring or trailing of anchors, cables or chains permitted on the side of the waterway on which the sign is placed
NMKINF20:	making fast to the bank permitted on the side of the waterway on which the sign is placed
NMKINF21:	berthing area reserved for loading and unloading vehicles
NMKINF22:	turning area
NMKINF23:	crossing with secondary waterway ahead
NMKINF24:	secondary waterway ahead on the right
NMKINF25:	secondary waterway ahead on the left
NMKINF26:	secondary waterway ahead (main waterway right)
NMKINF27:	secondary waterway ahead (main waterway left)
NMKINF28:	secondary waterway left (main waterway right)
NMKINF29:	secondary waterway right (main waterway left)
NMKINF30:	secondary waterway ahead and left (main waterway right)
NMKINF31:	secondary waterway ahead and right (main waterway left)
NMKINF32:	crossing with main waterway ahead
NMKINF33:	junction with main waterway ahead
NMKINF34:	junction with main waterway ahead and right
NMKINF35:	junction with main waterway ahead and left

NMKINF36:	junction with main waterway ahead and right (secondary waterway left)
NMKINF37:	junction with main waterway ahead and left (secondary waterway right)
NMKINF38:	end of prohibition or obligation applying to traffic in one direction only, or end of restriction
NMKINF39:	drinking water supply
NMKINF40:	telephone
NMKINF41:	motorized vessels permitted
NMKINF42:	sport and pleasure craft permitted
NMKINF43:	water skiing permitted
NMKINF44:	sailing vessels permitted
NMKINF45:	craft other than motorized vessels or sailing craft permitted
NMKINF46:	use of sailboards permitted
NMKINF47:	possibility of obtaining nautical information by radiotelephone on the channel indicated
NMKINF48:	water bikes permitted
NMKINF49:	zone authorized for high speed navigation of small sport and pleasure craft
NMKINF50:	launching or beaching of small craft permitted
NMKINF51-55:	maximum number of vessels permitted to berth abreast
NMKINF56:	electrical power supply point
NMKINF57:	winter harbour
NMKINF58:	winter shelter
NMKINF59:	use of spuds permitted
NMKINF60:	end of prohibition or obligation applying to traffic in one direction only, or end of restriction, orientation encoded

4.2.2 Notice marks for Russian inland waterways (the numbers refer to GOST 26600-98)

NMKPR101:	no anchoring or trailing of anchors, cables or chains (1.1)
NMKPR102:	no passing or overtaking of convoys (1.2)
NMKPR103:	no passing or overtaking (1.3)
NMKPR104:	do not create wash (1.4)
NMKPR105:	small crafts prohibited (1.5)
NMKRE101:	Attention! (keep caution) (2.1)
NMKRE102:	fairway crossing (2.2)

- NMKRE103: headroom limited (2.4)
- NMKIN101: turning area (3.2)
- NMKIN102: shipping inspection point (3.3)

























4.2.3 Auxiliary panels

- ADDMRK01: right (triangle to the right)
- ADDMRK02: left (triangle to the left)
- ADDMRK03: bottom (rectangle, portrait main board)
- ADDMRK04: top (rectangle, portrait main board)
- ADDMRK05: bottom (rectangle)
- ADDMRK06: top (rectangle)
- ADDMRK07: right (triangle to the right, landscape main board)
- ADDMRK08: left (triangle to the left, landscape main board)
- ADDMRK09: bottom (triangle to the bottom)
- ADDMRK10: bottom (triangle to the bottom, portrait main board)





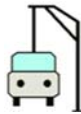









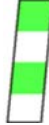







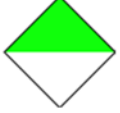









5. Pictures of Inland ECDIS symbols



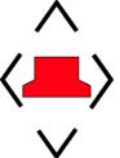
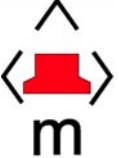









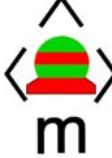











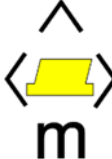



5.1 Raster symbols



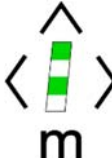











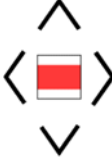
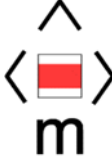





5.1.1 Symbols in general

					
BORDER01	BUNSTA01	BUNSTA02	BUNSTA03	BUNSTA04	CUSTOM01
					
DISMAR05	HECMTR01	HECMTR02	HGWTK01	LIFEBUOY01	NOTMRK01
					
NOTMRK02	NOTMRK03	NOTMRK04	NOTMRK05	NOTMRK06	REFDMP01
					
SSETR01	SSLOCK01	SSWARS01	TRNBSN01	VEHTRF01	VTCLMK01
					
WTLVGG02					





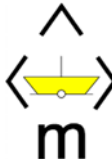

















5.1.2 Navigational aids

					
BCNSTK03	BCNLAT23	BOYLAT25	BOYLAT26	BOYLAT27	TOPMA100
					
TOPMA101	TOPMA102	TOPMA103	TOPMA104	TOPMA105	TOPMA106
					
TOPMA107	TOPMA108	TOPMA109	TOPMA110	TOPMA111	TOPMA112
					
TOPMA113	TOPMA114	TOPMA115	TOPMA116	TOPMA117	BOYINL01
					
BOYINL02	BOYINL03	BOYINL08			
					
BOYINL010	BOYINL01V	BOYINL01M	BOYINL01F		
					
BOYINL020	BOYINL02V	BOYINL02M	BOYINL02F		











































					
BOYINL03O	BOYINL03V	BOYINL03M	BOYINL03F		
					
BOYINL03OL	BOYINL03VL	BOYINL03ML	BOYINL03FL		
					
BOYINL03OR	BOYINL03VR	BOYINL03MR	BOYINL03FR		
					
BOYINL08O	BOYINL08V	BOYINL08M	BOYINL08F		
					
BOYLAT26O	BOYLAT26V	BOYLAT26M	BOYLAT26F		
					
BOYLAT27O	BOYLAT27V	BOYLAT27M	BOYLAT27F		
					
DFND01O	DFND01V	DFND01M	DFND01F		

 DFND02O	 DFND02V	 DFND02M	 DFND02F		
 TOPMA106O	 TOPMA106V	 TOPMA106M	 TOPMA106F		
 TOPMA108O	 TOPMA108V	 TOPMA108M	 TOPMA108F		
 TOPMA110O	 TOPMA110V	 TOPMA110M	 TOPMA110F		
 TOPMA112O	 TOPMA112V	 TOPMA112M	 TOPMA112F		
 SIGFLT01O		 SIGFLT01M	 SIGFLT01F		





5.1.3 Harbour facilities, terminals

					
HRBFAC10	HRBFAC11	HRBFAC12	HRBFAC13	HRBFAC14	HRBFAC15
					
HRBFAC16	HRBFAC17	HRBFAC18	TERMNL01	TERMNL02	TERMNL03
					
TERMNL04	TERMNL05	TERMNL06	TERMNL07	TERMNL08	TERMNL09
					
TERMNL10	TERMNL11	TERMNL12	TERMNL13		



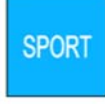







5.2 Symbols for the "information window on notice marks"

					
NMKPRH03	NMKPRH04	NMKPRH05	NMKPRH06	NMKPRH07	NMKPRH08
					
NMKPRH09	NMKPRH10	NMKPRH11	NMKPRH12	NMKPRH13	NMKPRH14
					
NMKPRH15	NMKPRH16	NMKPRH17	NMKPRH18	NMKPRH19	NMKPRH20
					
NMKPRH21	NMKPRH22	NMKPR101	NMKPR102	NMKPR103	NMKPR104
					
NMKPR105	NMKREG01	NMKREG02	NMKREG03	NMKREG04	NMKREG05
					
NMKREG06	NMKREG07	NMKREG08	NMKREG09	NMKREG10	NMKREG11
					
NMKREG12	NMKREG13	NMKREG14	NMKREG15	NMKREG16	NMKREG17

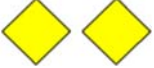
NMKREG18	NMKREG19	NMKREG20	NMKREG21	NMKREG22	NMKREG23
NMKREG24	NMKREG25	NMKRE101	NMKRE102	NMKRE103	
NMKRCD05	NMKRCD06	NMKRCD07	NMKRCD08	NMKINF02	NMKINF03
NMKINF04	NMKINF05	NMKINF06	NMKINF07	NMKINF08	NMKINF09
NMKINF10	NMKINF11	NMKINF12	NMKINF13	NMKINF14	NMKINF15
NMKINF16	NMKINF17	NMKINF18	NMKINF19	NMKINF20	NMKINF21
NMKINF22	NMKINF23	NMKINF24	NMKINF25	NMKINF26	NMKINF27
NMKINF28	NMKINF29	NMKINF30	NMKINF31	NMKINF32	NMKINF33

					
NMKINF34	NMKINF35	NMKINF36	NMKINF37	NMKINF38	NMKINF39
					
NMKINF40	NMKINF41	NMKINF42	NMKINF43	NMKINF44	NMKINF45
					
NMKINF46	NMKINF47	NMKINF48	NMKINF49	NMKINF50	NMKINF51
					
NMKINF52	NMKINF53	NMKINF54	NMKINF55	NMKINF56	NMKINF57
					
NMKINF58	NMKINF59	NMKINF60	NMKINF58	NMKIN101	NMKIN102
					
ADDMRK01	ADDMRK02	ADDMRK03	ADDMRK04	ADDMRK05	ADDMRK06
					
ADDMRK07	ADDMRK08	ADDMRK09	ADDMRK10		

5.3 Vector symbols

					
NMKINF01	NMKPRH02	NMKPRH12	NMKPRH13	NMKRCD01	NMKRCD02
					
NMKRCD03	NMKRCD04	NMKREG50	NMKREG51	DIRIMP	

6. Bathymetric IENCs

Bathymetric IENCs must be displayed as complementary layer only. It is not allowed to display bIENCs if the respective geographic area is not fully covered by an IENC or ENC. The usage of the respective ENCs/IENCs must be within the usage band of the bIENC. This means for example a bIENC with usage 5 to 7 may not be displayed together with an IENC of usage 4.

The bIENC has display priority over:

depare

DEPARE

DRGARE

DEPCNT

SOUNDG

UNSARE

M_COVR

and over the safety contour of the ENC or IENC. The bIENC must not have display priority over any other features of the IENC.

ANNEX 3

PRODUCT SPECIFICATION FOR BATHYMETRIC IENCs, EDITION 2.5

Unless it is specifically stated different in this Annex, the IENC Product Specification (Annex 1) is applicable for bathymetric IENCs as explained in the table below:

<adopted>	The definitions and sections of the Annex 1 apply completely for the bIENC Product Specification (100%)
<adopted with modifications>	The Annex 1 is relevant but for bIENCs slight deviations must be considered (e.g. exceptions). These modifications are described in the text of the relevant section.
<changed>	There's no need to refer to the Annex 1. Everything is defined in the relevant section marked as <changed>.
<n/a>	This section of the Annex 1 is not applicable for the bIENC Product Specification.

In the following the modifications, changes and/or extensions are listed.

1. Introduction

<changed>

The bathymetric IENC is a REF#IHO-S57 based product in addition to the already existing products (ENC, IENC).

The content of bathymetric ENC is limited to the bathymetry data only. The depth information can be encoded by means of the object classes depth area (DEPARE, depare), dredged area (DRGARE), depth contour (DEPCNT) and soundings (SOUNDG). Navigable areas without depths information are encoded as unsurveyed areas (UNSARE). Meta data is used to provide information about the pre-mentioned feature objects (e.g. accuracy and quality information).

Due to its limited content a bathymetric IENC does not comply with the existing ENC Product Specification. And it complies with the Product Specification for Inland ECDIS Edition 2.0, 2.1, 2.2, 2.3 neither.

Bathymetric IENCs must be regarded as bathymetric complement to ENC and IENCs. To make use of bathymetric IENCs a dedicated Product Specification for bathymetric IENCs is required. This Product Specification describes the dataset structure, topology, contents, meta information, object classes/attributes etc.

The use of bathymetric IENCs facilitates the incorporation of survey-sensor based depth information during the ENC production process. This is because the bathymetry is stored in separate datasets which are simply replaced when new depth data is available.

Unless it is specifically stated different in this Annex, the Annex 1 is applicable for bathymetric IENCs. In the following the modifications changes and/or extensions are listed.

A bathymetric IENC shall be produced in accordance with the regulations defined in:

- this Product Specification for bathymetric IENC;
- the Feature Catalogue for bathymetric IENC;
- the Encoding Guide for IENCs (especially pages C.1.1, C.1.4, C.1.6, C.1.7, C.1.8, I.1.1, I.1.2, I.1.3, I.1.6, I.1.7, I.1.8, I.1.9 and I.2.1).

The numbering correlates to the ENC Product Specification, REF#IHO-S57 Appendix B.1, Edition 2.0.

1.1 Definitions

<adopted with modifications>

1.2 Contents of the document

The bENC Product Specification contains one application profile for the basic bENC used to populate the SENC (EN application profile). An application profile for updating of the SENC (ER application profile) is not defined. The application profile is described in REF#IHO-S57 Part 3, clause 1.4.2.

2. General information

2.1 Navigational purpose

<changed>

Bathymetric IENCs make use of the same navigational purposes as ENCs (1 to 6) and IENCs (1 to 9). However, a bathymetric IENC has a range of categories of navigational purposes (e.g. from usage 4 to 9) it belongs to.

The INTU field of the REF#IHO-S57 Data Set Identification Record is used to indicate the navigational purpose of a cell. The expected input must be a binary value of type "unsigned integer". This is why each possible range of bIENC navigational purpose categories must be mapped to a value of this type.

The mapping is done by means of the following formula:

$$V_{INTU} = NP_{LC} * 10 + NP_{HC} + 128$$

Where

V_{INTU} : value of INTU field

NP_{LC} : lower category of navigational purpose

NP_{HC} : higher category of navigational purpose

Example: A usage range from 4 to 9 is mapped to the value $4*10+9+128 = 177$.

2.2 Cells

<changed>

In order to facilitate the efficient processing of bathymetric IENC data the geographic coverage of a given usage must be split into cells. Each cell of data must be contained in a physically separate, uniquely identified file on the transfer medium, known as a data set file (see paragraph 5.4 and 5.6.3).

The geographic extent of the cell must be chosen by the bathymetric IENC producer to ensure that the resulting data set file contains no more than 5 Megabytes of data. Subject to this consideration, the cell size must not be too small in order to avoid the creation of an excessive number of cells.

The coordinates of the borders of the cell are encoded in decimal degrees in the "Catalogue Directory" [CATD] field.

Point or line feature objects which are at the border of two cells with the same navigational purpose must be part of only one cell. They are put in the south or west cell (i.e. north and east borders of the cell are part of the cell, south and west borders are not).

When a feature object exists in several cells its geometry must be split at the cell boundaries and its complete attribute description must be repeated in each cell.

Bathymetric IENCs do not have to be rectangular. The meta object M_COVR with CATCOV1 is used to represent the geographic area containing data.

Data within bathymetric cells of the same navigational purpose must not overlap.

2.3 Topology

<changed>

Bathymetric IENCs use planar graph topology without faces (edges must not cross).

3. Features and attributes

3.1 Feature object identifiers

<adopted>

3.2 Standard features and attributes

<adopted with amendments>

Object classes defined in Annex 1, Appendix 1, but not listed in the following section of this document are prohibited for use in bIENCs.

3.3 Objects permitted for use in bIENC and their geometric primitives

<changed>

Following is a list of those features allowed in a bathymetric IENC and the geometric primitives allowed for each of them (P = point, L = line, A = area).

#		P	L	A
1	DEPCNT		L	
2	DEPARE			A
3	DRGARE			A
4	UNSARE			A
5	SOUNDG	P		
6	M_COVR			A
7	M_QUAL			A
8	M_SREL			A
9	M_SDAT			A
10	M_CSCL			A
11	M_NPUB			A
12	depare			A
13	m_sdat			A

The attributes and enumerations which may be used for the features are defined in the Feature Catalogue for bathymetric IENCs.

3.4 Meta features

<adopted with modifications>

A meta feature M_COVR is not required to cover any part of the cell that does not contain geographical data.

The meta features M_NSYS and m_nsys are not used.

3.5 Geo and meta feature attributes

3.5.1 Missing enumerations

<adopted>

3.5.2 Mandatory attributes

<changed>

The following table gives the attributes which are mandatory for each feature. When a feature is not in the list it means that there are no mandatory attributes for this feature.

Feature	Attributes					
DEPCNT	VALDCO					
DEPARE	DRVAL1	DRVAL2				
DRGARE	DRVAL1					
M_COVR	CATCOV 1					
M_QUAL	either:	CATZOC	or at least one of:	POSACC	SOUACC	TECSOU
M_SDAT	VERDAT					
M_CSCL	CSCALE					
depare	DRVAL1	DRVAL2	hunits	wtdis		
m_sdat	verdat					

3.5.3 Prohibited attributes

<adopted>

3.5.4 Numeric enumerations

<adopted>

3.5.5 Text enumerations

<adopted>

3.5.6 Hierarchy of meta data

<adopted>

3.6 Cartographic features

<adopted>

3.7 Time varying objects

<adopted>

3.8 Geometry

<adopted>

3.9 Relationships

<n/a>

3.10 Groups

<adopted>

3.10.1 Group 1 (skin of the earth)

<adopted with modifications>

The list below contains the features that must always be in Group 1, if they appear in the dataset and if they are of type area.

DEPARE DRGARE UNSARE depare

3.10.2 Group 2 (all other features)

<adopted>

3.11 Language and alphabet

3.11.1 Language

<adopted>

3.11.2 Use of lexical level 2

<adopted>

4. Cartographic framework

4.1 Horizontal datum

<adopted>

-
- 4.2 Vertical and sounding datum
 - <adopted>
 - 4.3 Projection
 - <adopted>
 - 4.4 Units
 - <adopted>
 - 5. Provision of data
 - 5.1 Implementation
 - <adopted>
 - 5.2 Compression
 - <adopted>
 - 5.3 Encryption
 - <adopted>
 - 5.4 Exchange set
 - If BIENC data is made available via SENC distribution section 5.4 is not applicable.
 - 5.4.1 Content of the exchange set
 - <adopted with modifications>
 - Picture files must not be included.
 - 5.4.2 Volume naming
 - <adopted>
 - 5.4.3 Directory structure
 - <adopted>
 - 5.5 Data sets
 - <modified>

Two kinds of data sets may be produced:

new data set: no bathymetric IENC data has previously been produced for this area and for the same navigational purpose.

new edition of a data set: new information which has not been previously distributed.

Updates and re-issues must not be produced.

5.6 File naming

5.6.1 README file

<adopted>

5.6.2 Catalogue file

<adopted with modifications>

Not applicable in case of SENC distribution.

5.6.3 Data set files

<modified>

The data set files are named according to the specifications given below:

CCBRRRRR.000

```

| | | | |
| | | | |----- 000 = extension*
| | | |----- RRRRR = waterway code and waterway distance (kilometre) or other
| | | |----- individual cell code.
| | | |-----
| |----- B = Product Id (bathymetric ENC)
|----- CC = producer code

```

The main part forms an eight character identifier where:

- the first two characters identify the producer;
- the third character indicates the Product Id;
- the fourth to eighth characters are used for the cell code. This code can be used in any way (e.g. to identify the waterway and the waterway distance) by the producer to provide the unique file name. If characters other than numbers are used only uppercase letters are allowed.

A valid base cell file must be uniquely identified worldwide by its name, and have the extension 000.

*In case of SENC distribution the extension may vary.

5.6.4 Text and picture files

<adopted with modifications>

Picture files are not used.

5.7 Updating

<changed>

In order to ensure that new editions are incorporated into the SENC in the correct sequence without any omission, the file extension and a number of subfields in the Data Set Identification [DSID] field are used in the following way:

file extension every new data set or new edition must have a 000 extension. In case of SENC distribution the extension may vary.

edition number when a data set is initially created, the edition number 1 is assigned to it. The edition number is increased by 1 at each new edition.

update number update number 0 is assigned to a new data set.

update application update application date

issue date date on which the data was made available by the data producer.

Each new edition of a data set must have the same name as the base cell file which it replaces. The ENC update mechanism is described in REF#IHO-S57 Part 3, clause 8.

In order to modify a text file, a new file with the same name is created.

5.8 Media

<adopted>

5.9 Error detection

<adopted>

6. Application profiles

6.1 General

<adopted>

6.2 Catalogue file

<adopted with modifications>

This section is not applicable in case of SENC distribution.

6.3 EN application profile

<adopted with modifications>

Data Set Identifier field [DSID]

The value of the INTU sub-field must be “unsigned binary”. It is determined by means of the following formula:

$$V_{INTU} = NP_{LC} * 10 + NP_{HC} + 128$$

Where

V_{INTU} : value of INTU field

NP_{LC} : lower category of navigational purpose

NP_{HC} : higher category of navigational purpose

Example: A usage range from 4 to 9 is mapped to the value $4*10+9+128 = 177$

In the PRSP (Product specification) subfield the value {200} is used as the indicator for a bathymetric ENC. The Product specification edition number is 1.0 (PRED subfield).

Data Set Parameter field – DSPM

In the VDAT (vertical datum) sub-field the value {255} (= null) is used.

In the SOMF (sounding multiplication factor) sub-field the value {100} is used.

6.4 ER application profile

<n/a>

ANNEX 4

IENC VALIDATION CHECKS, EDITION 2.5

Based on Special Publication REF#IHO-S58, Ed. 6.1.0 and Annex 11)

TABLE OF CONTENTS

1.	INTRODUCTION.....	365
1.1	DOCUMENT LAYOUT	365
1.2	CHECK CLASSIFICATION	366
1.3	MINIMUM CHECK STANDARD	366
1.4	GUIDELINES ON THE CHECK SYNTAX	366
1.4.1	<i>Comparison and Logical Operators</i>	367
1.4.2	<i>Spatial Operators</i>	367
1.4.3	<i>Values</i>	367
1.4.4	<i>Statements</i>	367
2.	GEOMETRY AND SPATIAL OPERATORS: TERMS AND DEFINITIONS.....	367
2.1	REF#ISO-19125 GEOMETRY	367
2.1.1	<i>Definitions for Geometry as defined in REF#ISO-19125</i>	368
2.1.2	<i>Definition of Symbols Used in REF#ISO-19125</i>	368
2.2	GEOMETRIC OPERATOR RELATIONSHIPS AS DEFINED IN REF#ISO-19125	369
2.3	HOW THE RELATIONSHIPS APPLY TO IENC FEATURES	370
2.4	GEOMETRIC OPERATOR DEFINITIONS	371
3.	VALIDATION CHECKS.....	378
3.1	CHECKS RELATING TO REF#IHO-S57 AND IENC DATA STRUCTURE	378
3.2	CHECKS RELATING TO THE ANNEX 1	396
3.3	EXCHANGE SET LEVEL CHECKS	408
3.4	CHECKS RELATING TO THE ENCODING GUIDE FOR IENCs	411
3.5	CHECKS RELATING TO ALLOWABLE ATTRIBUTE VALUES FOR PARTICULAR FEATURE OBJECT CLASSES	448

This publication contains material from REF#IHO-S58 (Edition 6.1.0) which is reproduced with the permission of the International Hydrographic Organization (IHO) Secretariat (Permission No 01/2024) acting for the International Hydrographic Organization (IHO). The IHO does not accept responsibility for the correctness of the material as reproduced, modified and translated by CESNI for "IENC Validation Checks". The incorporation of material sourced from IHO shall not be construed as constituting an endorsement by IHO of this publication.

1. Introduction

This Annex is based on REF#IHO-S58. It specifies the minimum checks that producers of IENC validation tools shall include in their validation software. This software will be used by chart producers to help ensure that their IENC data are compliant with Annex 1 (Product Specification for IENCs).

The checklist has originally been compiled for the IHO from lists of checks provided by a number of hydrographic offices and software companies. Then it has been adapted for IENCs by the IEHG before being further modified by CESNI.

1.1 Document Layout

The validation checks are laid out as follows:

No.	Check description	Check message	Check solution	Conformity to	Cat.
1500a	For each CBLARE feature object which is WITHIN OR OVERLAPS a LNDARE feature object of geometric primitive area.	CBLARE object overlaps a LNDARE object.	Amend objects to remove overlap.	Logical consistency	W
1500b	For each SBDARE feature object which is WITHIN OR CROSSES a LNDARE feature object of geometric primitive area.	SBDARE object is within or crosses a LNDARE object.	Amend objects to remove overlap.	Logical consistency	W
	Check removed				

Columns are as follows:

1. Check number.
2. Check description written in a defined syntax (wherever feasible) as defined in this Annex (see 1.4).
3. Check message to provide the user with meaningful information.
4. Check solution, suggested action to rectify a warning or (critical) error.
5. Conformity to, reference e.g. the location within the relevant section of the Product Specification for IENCs.
6. Check classification - Critical Error (C), Error (E), Warning (W) (see 1.2).

1.2 Check Classification

The classification ensures that the errors that affect the use can be identified and corrected. In some cases, it has been necessary to diverge from the strength of wording used in the IENC Product Specification or the IENC Encoding Guide. In such cases the impact on the user has been the overriding factor for consideration. The classifications have the following meanings:

C	Critical Error	An error which would make an IENC unusable in Inland ECDIS through not loading; or causing an Inland ECDIS to crash; or presenting data which is unsafe for navigation.
E	Error	An error which may degrade the quality of the IENC through appearance or usability, but which will not pose a significant danger when used to support navigation.
W	Warning	An error which may be duplication or an inconsistency which will not noticeably degrade the usability of an IENC in Inland ECDIS.

At a minimum validation software must group validation reports using these categories. The validation software may also support subgrouping of related checks such as those relating to geometric validity or attribute consistency. Software may allow checks of type Error or Warning to be deselected completely or by such categories.

1.3 Minimum Check Standard

Annex 1 specifies that IENC data must meet the minimum requirements defined in this Annex.

1.4 Guidelines on the Check Syntax

In order to ensure that checks can be interpreted clearly and consistently a defined syntax has been used for the reworded checks wherever possible. Each check is a statement which generates a Critical Error, Error or Warning if the expression returns 'true'.

In the below example the check would return true and give an error for each BERTHS feature object which carries the attribute VERDAT.

No.	Check description	Check message	Check solution	Conformity to:	Cat.
1571	For each BERTHS feature object where VERDAT is Present.	Prohibited attribute VERDAT populated for a BERTHS object.	Remove value of VERDAT from BERTHS object.	4.6.2	E

The elements of the syntax are defined as follows:

1.4.1 Comparison and Logical Operators

The following comparison and logical operators are used:

Equal
Not equal
Less than
Less than or equal to
Greater than
Greater than or equal to
AND
OR (inclusive OR)

1.4.2 Spatial Operators

Within this Annex the spatial operators (EQUALS, DISJOINT, TOUCHES, WITHIN, OVERLAPS, CROSSES, INTERSECTS, CONTAINS, and COINCIDENT), based on those laid out in the REF#ISO-19125, are used to describe spatial relationships tested within the checks. They are described in section 2.

For all spatial operators a default tolerance of 1 divided by the Coordinate multiplication factor should be applied in validation software.

1.4.3 Values

The following terms are used for types of values:

Present – An attribute is present and has been populated either with a value or null (255).

Null – An attribute is present and has a value of null (255).

notNull – The attribute is present and has been populated with a value.

1.4.4 Statements

The checks must be structured using the following statements:

- If – A conditional statement which determines whether a further statement should be executed.
- For – Repeat a statement until a statement is met (evaluates to “true”). For the purposes of the checks the statement being met generates the critical error, error or warning specified.

2. Geometry and spatial operators: terms and definitions

2.1 REF#ISO-19125 Geometry

This section defines REF#ISO-19125 geometric terms used in this Annex.

2.1.1 Definitions for Geometry as defined in REF#ISO-19125

- Note that these definitions are for the primitives defined by REF#ISO-19125 which are single Point, single Line and single Area geometry objects.
- Polygon – A polygon has a geometric dimension of 2. It consists of a boundary and its interior, not just a boundary on its own. It is a simple planar surface defined by 1 exterior boundary and 0 or more interior boundaries. The geometry used by an IENC Area feature is equivalent to a polygon.
- Polygon boundary – A polygon boundary has a geometric dimension of 1 and is equivalent to the outer and inner rings used by an IENC Area feature.
- LineString – A LineString is a Curve with linear interpolation between Points. A LineString has a geometric dimension of 1. It is composed of one or more segments – each segment is defined by a pair of points. The geometry used by an IENC Line feature is equivalent to a LineString.
- Line – A line as defined in REF#ISO-19125 is a LineString with exactly 2 points. Note that the geometry used by an IENC Line feature is equivalent to a LineString, not a line as defined in REF#ISO-19125. In this Annex the term Line refers to an IENC Line feature or a LineString which can have more than two points.
- Point – Points have a geometric dimension of 0. The geometry used by an IENC Point feature is equivalent to a point as defined in REF#ISO-19125.
- Reciprocal – inversely related or opposite.

The following table matches geometric terms as defined in REF#ISO-19125 to IENC terms, as defined in REF#IHO-S57 ENC:

Geometric terms	IENC terms
Polygon	Area feature geometry OR Face
Polygon boundary	Exterior and interior boundaries
LineString	Line feature geometry OR Line OR series of edges
Point	Point feature geometry OR Node OR vertex

2.1.2 Definition of Symbols used in REF#ISO-19125

- I = interior of a geometric object
- E = exterior of a geometric object
- B = boundary of a geometric object
- \cap = the set theoretic intersection
- U = the set theoretic union
- \wedge = AND
- Ú = OR
- \neq = not equal
- \emptyset = the empty or null set
- a** = first geometry, interior and boundary (the topological definition)
- b** = second geometry, interior and boundary (the topological definition)
- dim = geometric dimension – 2 for polygons, 1 for LineStrings and 0 for Points

Dim(x) returns the maximum dimension (-1, 0, 1, or 2) of the geometric objects in x, with a numeric value of -1 corresponding to dim (\emptyset).

Note:

- Neither interior nor exterior include the boundary (that is I, E and B are mutually exclusive).
- The boundary of a polygon includes its set of outer and inner rings.
- The boundary of a LineString is its end points except for a closed LineString, which has no boundary; the rest of the LineString is its interior.
- A Point does not have a boundary.

2.2 Geometric Operator Relationships as defined in REF#ISO-19125

The dimensionally extended nine-intersection model (DE-9IM) defines 5 mutually exclusive geometric relationships between two objects (polygons, LineStrings and/or Points). One and only one relationship will be true for any two given objects¹:

1. WITHIN
2. CROSSES
3. TOUCHES
4. DISJOINT
5. OVERLAPS

There are others that help further define the relationship:

1. CONTAINS
 - the reciprocal of WITHIN
 - within is the primary operator; however, if **a** is not within **b** then **a** may contain **b** so CONTAINS may be the unique relationship between the objects
2. EQUALS
 - a special case of WITHIN / CONTAINS
3. INTERSECTS
 - reciprocal of DISJOINT
 - have at least one point in common
4. COVERS and is COVERED_BY
 - reciprocal operators
 - extends CONTAINS and WITHIN respectively
5. COINCIDENT

Note that COVERS, COVERED_BY and COINCIDENT relational operators are not described in the REF#ISO-19125 document.

¹ CLEMENTINI, E., DI FELICE, P., VAN OOSTROM, P. A Small Set of Formal Topological Relationships Suitable for End-User Interaction, in D. Abel and B. C. Ooi (Ed.), Advances in Spatial Databases — Third International Symposium. SSD 1993. LNCS 692, pp. 277-295. Springer Verlag. Singapore (1993)

The formulas given in paragraph 2 of the validation checks (for example $a.\text{Disjoint}(b) \Leftrightarrow a \cap b = \emptyset$) are the generalised ones given for REF#ISO-19125, not the more specific DE-9IM formulas (that is, DE-9IM predicates). The generalised formulas use topologically closed notation (that is, geometry includes the interior and boundary unless otherwise stated), whereas the DE-9IM formulas refer to the interior and boundary of geometry separately. Note that different versions of documents describing ISO 19125-1 give different generalised formulas – this section is using the formulas that are the most consistent with the DE-9IM predicates. If a generalised formula appears to contradict a DE-9IM predicate as defined in REF#ISO-19125, the DE-9IM predicate takes precedence. Software is expected to be consistent with DE9IM predicates.

2.3 How the Relationships Apply to IENC Features

Geometric relationships will be tested on an entire IENC feature object as a single geometric entity. Note that IENC Point, Line and Area feature geometry is equivalent to Point, LineString and polygon geometry respectively (as defined in REF#ISO-19125).

A Line feature in IENC may be made up of several individual edges. The geometric relationship operators used with a Line feature will consider the sequence of edges as a single geometry (LineString).

A test on an Area feature will operate on the entire polygon.

In an IENC a Line or Area feature may be split into pieces as a result of a cutting operation from a data source. In that case each feature record in the dataset is treated as a separate LineString or polygon when testing geometric relationships.

If a test intends to operate only on a feature's specific components (Polygon boundary (all rings), polygon outer ring, polygon inner rings, edges, vertexes or nodes) then it must make this explicit in the description of the test. When a specific linear portion is specified in a test (Polygon boundary, edge) then it is treated as a LineString while individual vertexes or points will be treated as points.

For example a test to look for cases where object class A OVERLAPS object class B would operate on the entire geometry. While a test to see if boundary of Area object class A OVERLAPS an edge of Line class B will be comparing Area boundaries to edges using Line to Line comparisons.

2.4 Geometric Operator Definitions

The definitions below refer to REF#ISO-19125.

(In the diagrams within this section LineString corresponds to the IENC Line geometric primitive.)

EQUALS – Geometric object **a** is spatially equal to geometric object **b**.

The two geometric objects are the same. This is a special case of WITHIN.

Examples of the EQUALS relationship



Note: A more formal definition of equality is provided in REF#ISO-19107 as:

Two different GM_Objects are equal if they return the same Boolean value for the operation GM_Object: contains for every tested DirectPosition within the valid range of the coordinate reference system associated to the object.

NOTE: Since an infinite set of direct positions cannot be tested, the internal implementation of equal must test for equivalence between two, possibly quite different, representations. This test may be limited to the resolution of the coordinate system or the accuracy of the data. Application schemas may define a tolerance that returns true if the two GM_Objects have the same dimension and each direct position in this GM_Object is within a tolerance distance of a direct position in the passed GM_Object and vice versa.

For the purposes of the Recommended IENC Validation Checks, a GM_Object is any spatial object as described in A.1.1 (Polygons, LineStrings, and Points). A spatial object is always equal to itself; that is, **a EQUALS a** is always true.

DISJOINT – Geometric object **a** and geometric object **b** do not intersect.

The two geometric objects have no common points.

The definition of DISJOINT is:

$$\mathbf{a.Disjoint(b)} \Leftrightarrow \mathbf{a \cap b = \emptyset}$$

This translates to: **a** is disjoint from **b** if the intersection of **a** and **b** is the empty set.

Examples of the DISJOINT relationship

(i) area/area

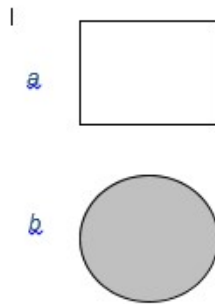

(ii) area/line

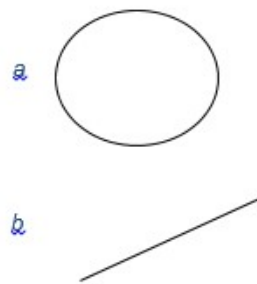

(iii) area/point

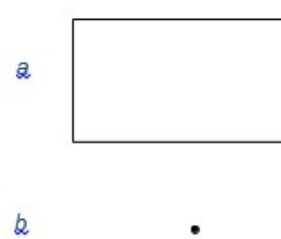

TOUCHES – Geometric object **a** intersects with geometric object **b** but they do not share interior points.

Only the boundary of one geometry intersects with the boundary of another geometry.

The only thing the geometric objects have in common is contained in the union of their boundaries.

The definition of TOUCHES is:

$$\mathbf{a.Touch(b)} \Leftrightarrow (I(\mathbf{a}) \cap I(\mathbf{b}) = \emptyset) \wedge (\mathbf{a} \cap \mathbf{b}) \neq \emptyset$$

This translates to: **a** touches **b** if the intersection of the interior of **a** and the interior of **b** is the empty set AND the intersection of **a** and **b** is not the empty set.

Note: This operator applies to the Area/Area, Line/Line, Line/Area, Point/Area and Point/Line relationships. It does not apply to a Point/Point relationship since points do not have a boundary.

Examples of the TOUCHES relationship

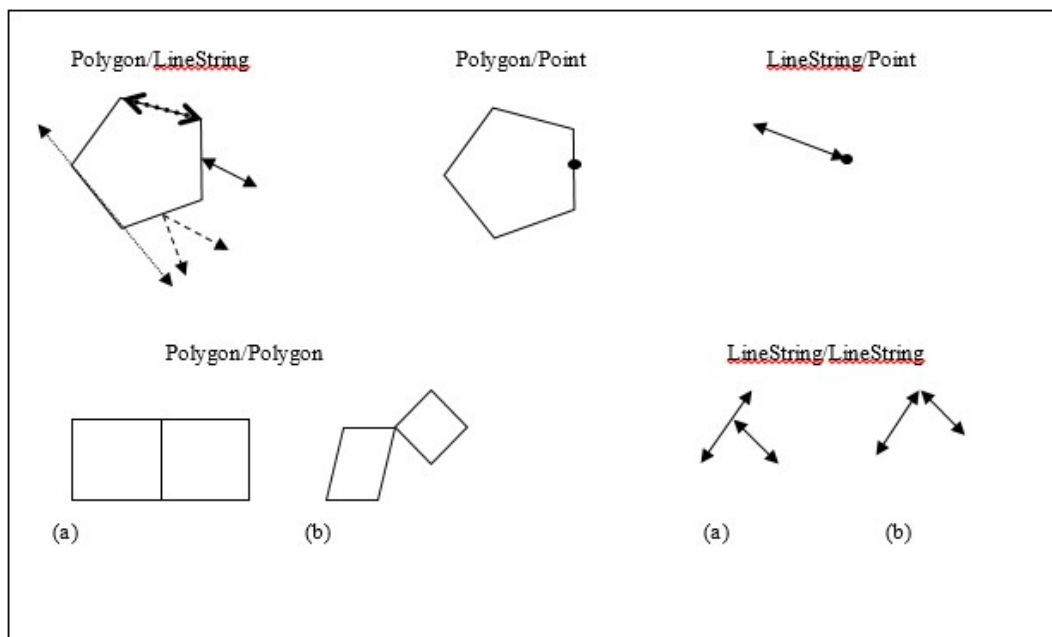

Note the polygon touches polygon example (a) is also a case where the polygon boundaries are COINCIDENT. In the polygon/LineString example two of the LineStrings that share a linear portion of the polygon boundary are also COINCIDENT with the polygon boundary.

WITHIN – Geometric object **a** is completely contained in geometric object **b**.

WITHIN includes EQUALS.

The definition of WITHIN is:

$$\mathbf{a}.\text{Within}(\mathbf{b}) \Leftrightarrow (\mathbf{a} \cap \mathbf{b} = \mathbf{a}) \wedge (I(\mathbf{a}) \cap I(\mathbf{b}) \neq \emptyset)$$

This translates to: **a** is within **b** if the intersection of **a** and **b** equals **a** AND the intersection of the interior of **a** and the interior of **b** is not the empty set.

Examples of the WITHIN relationship – polygon/polygon (a), polygon/LineString (b), LineString/LineString (c), polygon/Point (d), and LineString/Point (e)

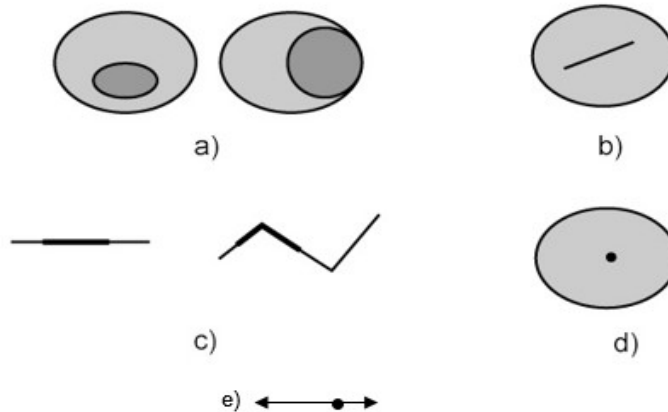

Note that a Line that completely falls on a polygon boundary is not WITHIN the polygon, it TOUCHES it. In that case it would also be COINCIDENT with the polygon boundary and COVERED_BY the polygon.

OVERLAPS - The intersection of two geometric objects with the same dimension results in an object of the same dimension but is different from both of them.

For two polygons or two LineStrings, part of each geometry, but not all, is shared with the other.

The OVERLAPS relationship is defined for Area/Area and Line/Line relationships. Points are either equal or disjoint.

Note that this does not include lines that cross.

The definition of OVERLAPS is:

$$a. \text{Overlaps}(b) \Leftrightarrow (\dim(I(a)) = \dim(I(b)) = \dim(I(a) \cap I(b))) \wedge (a \cap b \neq a) \wedge (a \cap b \neq b)$$

This translates to: **a overlaps b** if the geometric dimension of:

1. the interior of **a**
2. the interior of **b**
3. the intersection of the interiors of **a** and **b** are all equal AND the intersection of **a** and **b** does not equal either **a** or **b**.

Examples of the OVERLAPS relationship

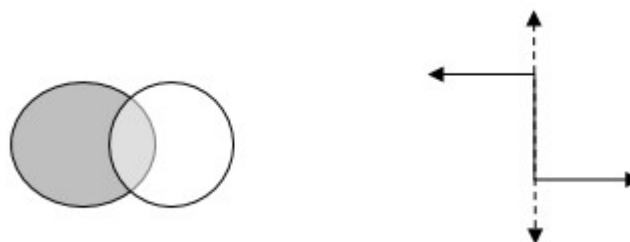

Note Lines that OVERLAP are also COINCIDENT.

CROSSES – The intersection of geometric object **a** and geometric object **b** returns geometry with a dimension less than the largest dimension between **a** and **b** but is not the same as geometric object **a** or **b**.

Two LineStrings cross each other if they meet on an interior point. A LineString crosses a polygon if the LineString is partly inside the polygon and partly outside.

The definition of CROSSES is:

$$\mathbf{a.Cross(b)} \Leftrightarrow (I(\mathbf{a}) \cap I(\mathbf{b}) \neq \emptyset) \wedge (\dim(I(\mathbf{a}) \cap I(\mathbf{b})) < \max(\dim(I(\mathbf{a})), \dim(I(\mathbf{b})))) \wedge (\mathbf{a} \cap \mathbf{b} \neq \mathbf{a}) \wedge (\mathbf{a} \cap \mathbf{b} \neq \mathbf{b})$$

This translates to: **a** crosses **b** if the intersection of the interiors of **a** and **b** is not the empty set AND the dimension of the result of the intersection of the interiors of **a** and **b** is less than the largest dimension between the interiors of **a** and **b** AND the intersection of **a** and **b** does not equal either **a** or **b**.

Note that “ $(I(\mathbf{a}) \cap I(\mathbf{b}) \neq \emptyset) \wedge$ ” was added to the beginning of the REF#ISO-19125 formula so that it would not be true for disjoint geometry.

The CROSSES operator only applies Line/Line and Line/Area relationships.

Examples of the CROSSES relationship

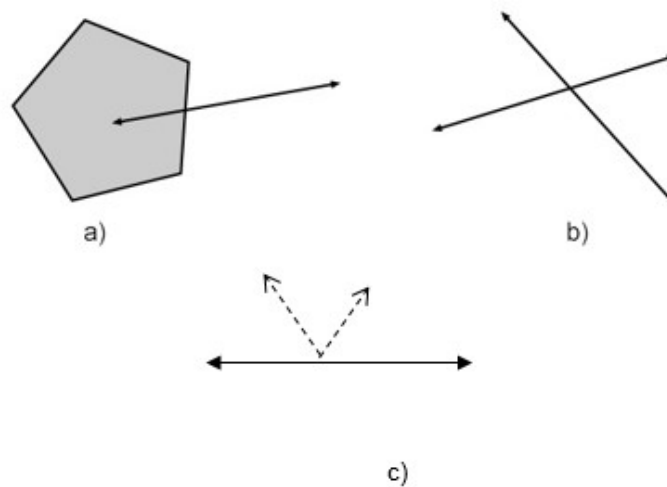

Note that example c shows one solid line and one dashed line – their interiors intersect. If any Line were split into two separate Line features at the intersection point then the relationship would be TOUCHES because a boundary would be involved.

INTERSECTS is the reciprocal of DISJOINT.

The two geometric objects cross, overlap or touch, or one is within (or is contained by) the other. They have at least one common point.

CONTAINS is the reciprocal of WITHIN.

*Given two geometric objects, **a** and **b**, if **a** is within **b** then **b** must contain **a**.*

COVERED_BY (not a standard REF#ISO-19125 operator) No point of geometry **a** is outside geometry **b**.

The definition of COVERED_BY is:

a. Covered_by (**b**) \Leftrightarrow ($\mathbf{a} \cap \mathbf{b} = \mathbf{a}$)

This translates to: **a** is covered_by **b** if the intersection of **a** and **b** equals **a**.

The following expressions are equivalent to **a** is COVERED_BY **b**:

Polygon (**a**) is COVERED_BY polygon (**b**): polygon **a** is WITHIN a polygon **b** (WITHIN includes EQUALS)

Point (**a**) is COVERED_BY polygon (**b**): Point **a** is WITHIN or TOUCHES polygon **b**

Line (**a**) is COVERED_BY polygon (**b**): Line **a** is WITHIN polygon **b** or WITHIN the boundary of polygon **b**

Line (**a**) is COVERED_BY Line (**b**): Line **a** is WITHIN Line **b** (WITHIN includes EQUALS)

Point (**a**) is COVERED_BY Line (**b**): Point **a** is WITHIN or TOUCHES Line **b**

Point (**a**) is COVERED_BY Point (**b**): Point **a** EQUALS Point **b**

Note that the figure below on the left is an example of Lines that are COVERED_BY a polygon.

The figure on the right is not an example of a Line that is covered by a polygon – it is an example of a Line that TOUCHES a polygon. In both cases the Lines are COINCIDENT with the polygon boundary.



COVERS (not a standard ISO REF#ISO-19125 operator)

COVERS is the reciprocal of COVERED_BY.

*Given two geometric objects, **a** and **b**, if **a** is COVERED_BY **b** then **b** must cover **a**.*

COINCIDENT (not an REF#ISO-19125 operator)

Two geometric Lines OVERLAP or one geometric Line is WITHIN the other. Note that EQUAL Lines are also COINCIDENT by this definition.

The intersection of two geometric Lines results in one or more Lines.

This operator is only to be used to compare a Line with another Line. Note that normally the boundary of a polygon is not the same as a Line but for this operation the boundary of a polygon, exterior and interior rings, is treated as Lines for the COINCIDENT test.

The following expressions are equivalent to **a** is COINCIDENT with **b**:

1. Polygon (**a**) is COINCIDENT with polygon (**b**): The boundary of polygon **a** OVERLAPS or is WITHIN the boundary of polygon **b**.
2. Line (**a**) is COINCIDENT WITH polygon (**b**): Line **a** OVERLAPS or is WITHIN the boundary of polygon **b**.
3. Line (**a**) is COINCIDENT WITH Line (**b**): Line **a** OVERLAPS or is WITHIN Line **b**.

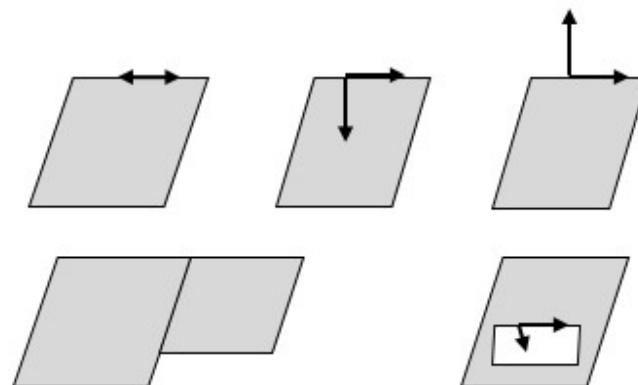
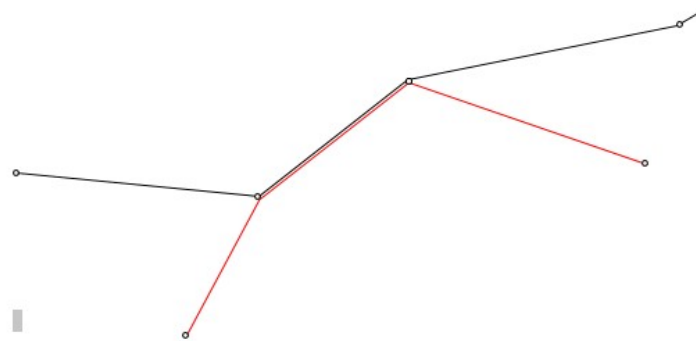
Example of the COINCIDENT relationship

Above are other examples of objects *COINCIDENT* with the boundary of a polygon. *LineStrings* following a portion of a polygon boundary or polygons sharing a boundary portion.

Note that by definition a *Line* can be *COINCIDENT* with an interior boundary of a polygon.

Note that other relationships may also be true such as *COVERED_BY* or *TOUCHES* since *COINCIDENT* is not mutually exclusive.

3. Validation checks

3.1 Checks relating to REF#IHO-S57 and IENC Data Structure

No.	Check description	Check message	Check solution	Conformity to:	Cat.
1	For each edge which is <i>COINCIDENT</i> with another edge.	Partially duplicated edges.	Remove duplication, add nodes and edit edges as required.	REF#IHO-S57 Part 2 (2.2.1.2)	E
2	For each edge which does not have a beginning or end node.	VE edge missing beginning or end node.	Add nodes as required.	REF#IHO-S57 Part 2 (2.2.1.2)	C
3	For each record where the record identifier NAME (concatenation of the RCNM & RCID subfields) is not unique within the file.	Record identifier NAME is not unique.	Amend Record identifier NAME to be unique.	REF#IHO-S57 Part 3 (2.2)	C
4	For each RCNM where the value is not in table 2.2 of REF#IHO-S57 Part 3.	Invalid value of RCNM.	Amend RCNM value	REF#IHO-S57 Part 3 (2.2.1)	C
5	For each RCID which is Less than 1 OR Greater than $2^{32}-2$ (4294967294).	RCID is out of range.	Amend RCID value.	REF#IHO-S57 Part 3 (2.2.2)	C
	<i>Check removed.</i>				
7	For each feature object with invalid AGEN, FIDN or FIDS values.	Invalid values of AGEN, FIDN or FIDS.	Amend AGEN, FIDN or FIDS value.	REF#IHO-S57 Part 3 (4.3.1) and (4.3.2)	C
8	For each feature object where an attribute code is repeated.	Duplicate attribute code on an object.	Remove or amend duplicate attribute code.	REF#IHO-S57 Part 3 (4.4), (4.5) and (5.1.2)	C
9a	For each feature object of geometric primitive line where ORNT is Not equal to 1 (forward) OR 2 (reverse).	Invalid value of ORNT.	Set value of ORNT to 1 (forward) or 2 (reverse).	REF#IHO-S57 Part 3 (4.7.2)	C

No.	Check description	Check message	Check solution	Conformity to:	Cat.
9b	For each feature object of geometric primitive line where USAG is Not equal to Null.	Invalid value of USAG.	Set value of USAG to 255 (null).	REF#IHO-S57 Part 3 (4.7.2) and Annex 1 (3.8)	C
9c	For each feature object of geometric primitive line where MASK is notNull AND is Not equal to 1 (mask) AND is Not equal to 2 (show).	Invalid value of MASK.	Set MASK to 1 (mask), 2 (show) or Null.	REF#IHO-S57 Part 3 (4.7.2) and Annex 1 (3.8)	C
10a	For each feature object of geometric primitive point where ORNT is Not equal to 255 (direction is not relevant).	Invalid value of ORNT.	Set ORNT to 255 (direction is not relevant).	REF#IHO-S57 Part 3 (4.7.1)	E
10b	For each feature object of geometric primitive point where USAG is Not equal to 255 (null).	Invalid value of USAG.	Set USAG to 255 (null).	REF#IHO-S57 Part 3 (4.7.1)	E
10c	For each feature object of geometric primitive point where MASK is Not equal to 255 (masking is not relevant).	Invalid value of MASK.	Set MASK to 255 (masking is not relevant).	REF#IHO-S57 Part 3 (4.7.1)	C
11	For each edge reference where USAG is Equal to 3 (exterior boundary truncated by the data limit) not also referenced by a M_COVR meta object.	Edge reference with USAG = 3 (exterior boundary truncated by the data limit) is not referenced by a M_COVR object.	Set USAG to 1 (exterior) or 2 (interior).	REF#IHO-S57 Part 3 (4.7.3.3)	E
12	For each feature object (excluding C_AGGR and C_ASSO collection objects) which does not reference a spatial record.	Feature object without geometry.	Remove the feature object or reference the feature object to a spatial record of allowable geometric primitive.	REF#IHO-S57 Part 3 (4.7)	C
13a	For each feature object of geometric primitive line which references multiple edges where the vector records are not referenced sequentially.	Edges are not referenced sequentially.	Amend records to reference edges sequentially.	REF#IHO-S57 Part 3 (4.7.2)	C

No.	Check description	Check message	Check solution	Conformity to:	Cat.
13b	For each feature object of geometric primitive line which references multiple edges where the end node of a vector record is not identical to the beginning node of the following vector record.	Sequential edges do not have the same end and beginning nodes.	Ensure end and beginning nodes of sequential edges match.	REF#IHO-S57 Part 3 (5.1.3.2)	C
13c	For each feature object of geometric primitive area where a polygon ring references multiple edges where the vector records are not referenced sequentially.	Edges are not referenced sequentially.	Amend records to reference edges sequentially.	REF#IHO-S57 Part 3 (4.7.2) and (4.7.3)	C
13d	For each feature object of geometric primitive area where a polygon ring references multiple edges where the end node of a vector record is not identical to the beginning node of the following vector record.	Sequential edges do not have the same end and beginning nodes.	Ensure end and beginning nodes of sequential edges match.	REF#IHO-S57 Part 3 (4.7.2) and (4.7.3)	C
14	For each feature object of geometric primitive area where the exterior boundary shares more than one node with an interior boundary.	Exterior and interior boundaries share more than one node.	Amend boundary to share at most one node.	REF#IHO-S57 Part 3 (4.7.3)	C
15	For each feature object of geometric primitive area where the exterior boundary or an interior boundary is not closed.	First and last edge of an area boundary do not meet at a common connected node.	Amend edges bounding the area to meet at a common connected node.	REF#IHO-S57 Part 3 (4.7.3.1)	C
16	For each feature object of geometric primitive area where the exterior boundary is not encoded clockwise.	Area exterior boundary not encoded clockwise.	Ensure area exterior boundary is encoded clockwise.	REF#IHO-S57 Part 3 (4.7.3.2)	C
17	For each feature object of geometric primitive area where an interior boundary is not encoded counterclockwise.	Area interior boundary not encoded counterclockwise.	Ensure area interior boundary is encoded counterclockwise.	REF#IHO-S57 Part 3 (4.7.3.2)	C

No.	Check description	Check message	Check solution	Conformity to:	Cat.
18a	For each feature object of geometric primitive area where the number of exterior boundaries is Not equal to 1.	Area object without an exterior boundary or with several exterior boundaries.	Amend geometry so that area object has one exterior boundary.	REF#IHO-S57 Part 3 (4.7.3.2) and (4.7.3.3)	C
18b	For each feature object of geometric primitive area where the exterior boundary is not referenced first.	Area object with exterior boundary which is not referenced first.	Amend geometry so that the exterior boundary is referenced first.	REF#IHO-S57 Part 3 (4.7.3.1), (4.7.3.2) and (4.7.3.3)	C
18c	For each feature object of geometric primitive area with one or more interior boundaries where any interior boundary does not have USAG set to 2 (interior boundary).	Interior boundary has invalid USAG value.	Amend edge to USAG = 2 (interior boundary).	REF#IHO-S57 Part 3 (4.7.3.2) and (4.7.3.3)	C
19	For each edge which is COINCIDENT with the data limit borders (i.e. limits of M_COVR with CATCOV is Equal to 1 (coverage available)) where USAG is Not equal to 3 (exterior boundary truncated by the data limit).	Edge coincides with the data limit and USAG does not equal 3 (exterior boundary truncated by the data limit).	Amend edge to USAG = 3 (exterior boundary truncated by the data limit).	REF#IHO-S57 Part 3 (4.7.3.3)	W
20a	For each feature object where a geometric primitive is not one of those permitted.	Geometric primitive of this type is not permitted for this object class.	Use alternative geometric primitive or alternative object class as required.	REF#IHO-S57 Part 3 (4.2.1), Annex 1 (3.3) and Annex 1, Appendix 2	C
20b	For each spatial record which is not referenced by a feature object.	Orphaned geometry.	Remove orphaned geometry.	Logical consistency and REF#IHO-S57 Part 2 (1)	C
21	For each VRPT field which is not pointed to by an edge vector record.	VRPT field not referenced by an edge vector record.	Ensure VRPT field is referenced by an edge vector record or remove.	REF#IHO-S57 Part 3 (5.1.3)	C

No.	Check description	Check message	Check solution	Conformity to:	Cat.
22	For each edge where the End node is referenced before the beginning node.	Beginning and end nodes are not in the correct sequence.	Amend edge to reference beginning node before end node.	REF#IHO-S57 Part 3 (5.1.3.2)	C
23	For each coordinate which is not a SG2D or SG3D field.	Coordinate is not a SG2D or SG3D field.	Amend coordinate to valid field.	REF#IHO-S57 Part 3 (5.1.4)	C
24	For each SOUNDG feature object which does not reference a SG3D field with X, Y and Z values.	SOUNDG does not reference a SG3D field.	Amend coordinate type or values for SOUNDG.	REF#IHO-S57 Part 3 (5.1.4.1)	C
25a	For each edge where the beginning and end are not encoded as connected nodes.	Beginning or end nodes of an edge are not encoded as connected nodes.	Amend beginning or end nodes to be connected nodes.	REF#IHO-S57 Part 3 (5.1.4.4)	C
	<i>Check removed.</i>				
25c	For each edge where the beginning or end node is not referenced using the vector record pointer.	Beginning or end nodes not referenced by the vector record pointer.	Amend edge to ensure beginning and end nodes are referenced.	REF#IHO-S57 Part 3 (5.1.4.4)	C
26a	For each subfield where the value is not within the range defined in the REF#IHO-S57 format description.	Subfield value does not conform to REF#IHO-S57 format specification.	Amend subfield value.	REF#IHO-S57 Part 3 (7.2.2.1) and (7.3)	C
26b	For each subfield value which is not within the legal range for attribute values (for attribute values of type "float", the resolution given in the format statement by the integer part (e.g. XX.X) must not be checked).	Subfield value outside of the permitted range for an attribute value.	Amend subfield value to permitted attribute value.	Annex 1, Appendix 1	E
27	For each subfield which is not formatted in accordance with REF#IHO-S57.	Subfield not formatted in accordance with S57.	Amend formatting of subfield value.	REF#IHO-S57 Part 3 (7.2.2.2)	C

No.	Check description	Check message	Check solution	Conformity to:	Cat.
28	If the count of records in the DSSI field is Not equal to the total number of records.	DSSI field record count incorrect.	Amend the DSSI field record count.	REF#IHO-S57 Part 3 (7.3.1.2)	E
29	For each of the following: FFPC-NFPT, FSPC-NSPT, SGCC-CCNC, and VRPCNVPT subfields where the value is Not equal to the number of records/pointers.	Invalid number of records/pointers in the following FFPC-NFPT, FSPC-NSPT, SGCC-CCNC or VRPC-NVPT.	Amend subfield to equal the number of records/pointers.	REF#IHO-S57 Part 3 (7.6.5) (7.6.7), (7.7.1.5) and (7.7.1.3)	C
30	For each of the following: FFPC-FFIX, FSPC-FSIX, SGCC-CCIX, and VRPC-VPIX subfields where the index position for updating is invalid.	Invalid index position for updating in the following subfields FFPC-FFIX, FSPC-FSIX, SGCC-CCIX or VRPC-VPIX.	Amend to valid index position for updating.	REF#IHO-S57 Part 3 (7.7.1.5), (7.6.5), (7.6.7) and (7.7.1.3)	C
31	For each edge where SG2D coordinates are identical to the beginning or end node coordinates.	Edge where beginning or end node coordinates are the same as the SG2D coordinates.	Amend SG2D coordinates to differ from beginning and end node coordinates.	REF#IHO-S57 Part 3 (7.7.1.6)	C
32	For each record update which does not refer to a valid record NAME.	Record update does not refer to a valid record NAME.	Amend record update to refer to a valid record NAME.	REF#IHO-S57 Part 3 (8.3.2)	C
33	For each attribute update which does not refer to a valid record NAME and attribute label/code.	Attribute update does not refer to valid record NAME and attribute label/code.	Amend attribute update to refer to valid values.	REF#IHO-S57 Part 3 (8.3.3)	C

No.	Check description	Check message	Check solution	Conformity to:	Cat.
34	For each of the following fields FFPT, FSPT or VRPT where the update pointer index does not refer to a valid record NAME and index.	Update pointer index does not refer to a valid record NAME and index for FFPT, FSPT or VRPT.	Ensure update pointer index refers to a valid record NAME and index.	REF#IHO-S57 Part 3 (8.3.4)	C
35	For each feature object where RVER is out of sequence.	RVER is out of sequence.	Ensure RVER is sequential.	REF#IHO-S57 Part 3 (8.4.2.1) and (8.4.3.1)	C
36a	For each feature or vector update record which is DELETE AND contains further fields.	DELETE update contains additional fields.	Remove additional fields from update record.	REF#IHO-S57 Part 3 (8.4.2.2) and (8.4.3.2)	C
36b	For each feature or vector update record which is MODIFY OR INSERT and contains no further fields.	MODIFY or INSERT update does not contain additional fields.	Add additional fields to update record.	REF#IHO-S57 Part 3 (8.4.2.2) and (8.4.3.2)	C
	<i>Check renumbered 1006.</i>				
38	For each update record which contains more than one of the following fields: FFPC, VRPC, FSPC or SGCC.	Update record contains more than one of the following fields: FFPC, VRPC, FSPC or SGCC.	Remove additional fields from update record.	REF#IHO-S57 Part 3 (8.4.2.3), (8.4.3.2b), (8.4.2.4) and (8.4.3.3)	C
	<i>Check removed.</i>				
40	For any pair of feature objects of geometric primitive line where class and attribute values are identical AND which have one or two common connected nodes which is (are) a beginning node or an end node of each linear feature AND each common connected node is not shared by more than two objects which are not chained together.	Linear objects with the same class and attribute values which are connected and are not chained together.	Chain linear objects together.	Logical consistency	W
	<i>Check removed.</i>				

No.	Check description	Check message	Check solution	Conformity to:	Cat.
42	For each edge which is referenced by Group 1 objects AND is not referenced by a M_COVR meta object with CATCOV is Equal to 1 (coverage available) which does not appear twice with different ORNT (forward and reverse) values.	Group 1 coverage is not correct, a hole or an overlap exists.	Amend Group 1 coverage, to remove hole or overlap.	Annex 1 (3.10.1) and Logical consistency	C
43	For each DEPCNT feature object which is not COINCIDENT with two Group 1 feature objects AND is not WITHIN an UNSARE or DRGARE.	DEPCNT does not coincide with two Group 1 objects.	Amend DEPCNT or Group 1 objects as required.	Annex 1 (3.10.1), Annex 1, Appendix 2 I.2.1	W
44	For each DRVAL1 or DRVAL2 value (except the shallowest and the deepest found in the IENC) for a DEPARE and depare feature object which is not Equal to a value of VALDCO on DEPCNT feature objects found in the IENC.	The value of DRVAL1 or DRVAL2 is different from one of the values of VALDCO found in the IENC.	Amend value of DRVAL1 or DRVAL2 so that it equals a value of VALDCO.	Logical consistency	W
45a	For each feature object (excluding berths, cblohd, CBLSUB, CONVYR, convyr, FERYRT, feryrt, MARCUL, MORFAC, NAVLNE, PIPSOL and RECTRC) of geometric primitive line which is COINCIDENT with another feature object of the same class and geometric primitive.	Coincident linear objects of the same class.	Remove coincident object.	Logical consistency	W
45b	For each berths, cblohd, CBLSUB, CONVYR, convyr, FERYRT, feryrt, MARCUL, MORFAC, NAVLNE, PIPSOL, or RECTRC feature object of geometric primitive line which is COINCIDENT with another feature object of the same class and geometric primitive and the same attribute values.	Coincident line objects of the same class and attribute values.	Remove coincident object.	Logical consistency	W
46	For each feature object where DATEND and DATSTA are notNull AND DATEND is Less than or equal to DATSTA.	DATEND is less than or equal to DATSTA.	Amend values of DATEND or DATSTA accordingly.	Logical consistency	E

No.	Check description	Check message	Check solution	Conformity to:	Cat.
47a	For each LIGHTS feature object where SECTR1 is notNull AND SECTR2 is Null OR is Equal to SECTR1. (0 and 360 must be treated as the same value.)	SECTR2 not populated with a valid value, must not be the same as SECTR1.	Populate SECTR2 with a valid value.	Logical consistency	E
47b	For each LIGHTS feature object where SECTR2 is notNull AND SECTR1 is Null OR is Equal to SECTR2. (0 and 360 must be treated as the same value.)	SECTR1 not populated with a valid value, must not be the same as SECTR2.	Populate SECTR1 with a valid value.	Logical consistency	E
48	<i>No attributes SCVAL1 and SCVAL2 in Annex 1, Appendix 1</i>				
49	For each feature object where DRVAL1 and DRVAL2 are notNull AND DRVAL2 is Less than DRVAL1.	DRVAL2 is less than DRVAL1, DRVAL2 must be greater than or equal to DRVAL1.	Amend the values of DRVAL1 or DRVAL2 as required.	Logical consistency	E
50	For each RECTRC feature object of geometric primitive line where CATTRK is Equal to 1 (based on a system of fixed marks) OR NAVLNE feature object where its nodes/vertices do not lie on a straight (rhumb) line OR orthodromic line.	RECTRC where CATTRK = 1 (based on a system of fixed marks) or NAVLNE is not a straight line.	Amend geometry to a straight line.	Logical consistency	E
51a	For each COALNE feature object which is COINCIDENT with a SLCONS or slcons feature object of geometric primitive line.	COALNE and SLCONS/slcons objects share an edge.	Amend objects so that they do not share an edge.	Logical consistency	W
51b	For each COALNE feature object which is COINCIDENT with a SLCONS or slcons feature object of geometric primitive area where WATLEV/watlev is Equal to 1 (partly submerged at high water) OR 2 (always dry) OR is not Present that is WITHIN a LNDARE feature object of geometric primitive area.	COALNE and SLCONS/slcons with illogical values of WATLEV/walev overlap.	Amend objects so that they do not overlap or amend WATLEV/watlev values.	Logical consistency	W

No.	Check description	Check message	Check solution	Conformity to:	Cat.
52a	No LNDELV in Annex 1, Appendix 1				
52b	No LNDELV in Annex 1, Appendix 1				
53a	For each SLOGRD feature object which is not COVERED_BY a LNDARE feature object of geometric primitive area.	SLOGRD not covered by LNDARE.	Amend LNDARE or SLOGRD accordingly.	Annex 1, Appendix 2, D.2.3 B), D.2.4 C), E.3.2 B)	E
53b	For each SLOTOP feature object which is not WITHIN a LNDARE feature object of geometric primitive area.	SLOTOP not within LNDARE.	Amend LNDARE or SLOTOP accordingly.	Annex 1, Appendix 2, D.2.3 B) and C), D.2.4 C) and D)	E
54a	For each FORSTC, LNDMRK or SILTNK feature which is not COVERED_BY a BRIDGE, bridge, COALNE, DAMCON, FLODOC, flodoc, HULKES, hulkes, LNDARE, OFSPLF, PILPNT, PONTON, ponton, PYLONS, SLCONS, slcons or UWTROC or uwtrroc feature object.	FORSTC, LNDMRK or SILTNK not covered by a suitable supporting object.	Amend object to ensure it is situated on a suitable object.	Logical consistency	C
54b	For each DAYMAR feature object which is not a slave in a master/slave relationship AND is not COVERED_BY a BRIDGE, bridge, COALNE, DAMCON, FLODOC, flodoc, HULKES, hulkes, LNDARE, OFSPLF, PILPNT, PONTON, ponton, PYLONS, SLCONS, slcons or UWTROC or uwtrroc feature object.	DAYMAR not covered by a suitable supporting object.	Amend object to ensure it is situated on a suitable object.	Logical consistency	C
54c	For each BUISGL, CRANES or cranes feature object which is not COVERED_BY a BRIDGE, bridge, COALNE, DAMCON, FLODOC, flodoc, HRBFAC, hrbfac, LNDARE, OFSPLF, PILPNT, PONTON, ponton, PYLONS or SLCONS or slcons feature object.	BUISGL, CRANES or cranes not covered by a suitable supporting object.	Amend object to ensure it is situated on a suitable object.	Logical consistency	W

No.	Check description	Check message	Check solution	Conformity to:	Cat.
55	For each LNDARE feature object of geometric primitive point or line which is COVERED_BY a LNDARE feature object AND is not COVERED_BY a CANALS, LAKARE, lokbsn, lkbspt or RIVERS feature object.	Point or line LNDARE lies on LNDARE.	Ensure LNDARE is not covered by a LNDARE.	Logical consistency	W
56	For each BUAARE feature object which is not COVERED_BY a LNDARE feature object.	BUAARE not located on LNDARE.	Amend BUAARE so that it is covered by a LNDARE.	Logical consistency	E
57a	For each COALNE feature object where CATCOA is Not equal to 7 (mangrove) which is not COINCIDENT with a LNDARE feature object AND is not WITHIN a LNDARE feature object of geometric primitive area.	COALNE object not bounding LNDARE.	Ensure that COALNE coincides with LNDARE boundary.	Logical consistency	E
57b	For each COALNE feature object which is WITHIN a LNDARE feature object of geometric primitive area OR is COINCIDENT with LNDARE feature objects on both sides AND is COINCIDENT with a SLCONS, slcons or DRYDOC feature object where CONDTN is Not equal to 1 (under construction) OR 3 (under reclamation) OR 5 (planned construction).	COALNE is within a LNDARE or is coincident with a permanent SLCONS, slcons or DRYDOC object.	Remove COALNE or amend CONDTN values.	Logical consistency	E
57c	<i>LNDARE does not have CONDTN in Annex 1, Appendix 1</i>				
57d	<i>VEGATN does not have CATVEG 7 in Annex 1, Appendix 1</i>				
58	For each SBDARE feature object of geometric primitive line which is COINCIDENT with a SBDARE feature object of geometric primitive area.	Line SBDARE bounds an area SBDARE.	Remove linear SBDARE.	Logical consistency	W
59	For each OBSTRN feature object of geometric primitive line which is COINCIDENT with an OBSTRN feature object of geometric primitive area.	Line OBSTRN bounds an area OBSTRN.	Amend or remove linear OBSTRN.	Logical consistency	W

No.	Check description	Check message	Check solution	Conformity to:	Cat.
60	For each CBLSUB feature object which is WITHIN OR CROSSES a LNDARE feature object of geometric primitive area.	CBLSUB covered by LNDARE.	Ensure CBLSUB is not covered by a LNDARE.	Logical consistency	W
61a	For each feature object of geometric primitive line where WATLEV/watlev is Equal to 3 (always underwater/submerged) which is WITHIN OR CROSSES a LNDARE feature object of geometric primitive area OR is WITHIN OR CROSSES an intertidal area (DEPARE/depere feature object where DRVAL2 is Less than or equal to 0).	Linear object where WATLEV/watlev = 3 (always underwater/submerged) is within or crosses a LNDARE or intertidal area (DEPARE/depere with $DRVAL2 \leq 0$).	Amend value of WATLEV/watlev.	Logical consistency	E
61b	For each feature object of geometric primitive point where WATLEV/watlev is Equal to 3 (always underwater/submerged) which is not COVERED_BY a DEPARE/depere feature object where DRVAL2 is Greater than 0 OR is COVERED_BY a LNDARE feature object of geometric primitive point or line.	Point object where WATLEV/watlev = 3 (always underwater/submerged) is not covered by a suitable depth area.	Amend value of WATLEV/watlev.	Logical consistency	E
61c	For each feature object of geometric primitive area where WATLEV/watlev is Equal to 3 (always underwater/submerged) which is WITHIN OR OVERLAPS a LNDARE feature object of geometric primitive area OR is WITHIN OR OVERLAPS an intertidal area (DEPARE/depere feature object where DRVAL2 is Less than or equal to 0).	Area object where WATLEV/watlev = 3 (always underwater/submerged) is within or overlaps a LNDARE or intertidal area (DEPARE/depere with $DRVAL2 \leq 0$).	Amend value of WATLEV/watlev.	Logical consistency	E

No.	Check description	Check message	Check solution	Conformity to:	Cat.
62	For each PONTON, ponton, HULKES, hulkes or FLODOC or flodoc feature object of geometric primitive area where any edge shares the geometry of a COALNE or SLCONS or slcons feature object of geometric primitive line AND the edge is not COINCIDENT with a LNDARE feature object of geometric primitive area.	PONTON, ponton, HULKES, hulkes or FLODOC or flodoc which shares an edge with a SLCONS, slcons or COALNE which is not on the edge of a LNDARE.	Ensure all SLCONS, slcons or COALNE objects are backed by LNDARE objects.	Logical consistency	W
63	For each RECTRC feature object which INTERSECTS LNDARE, PONTON, ponton, HULKES, hulkes, or FLODOC or flodoc feature objects of geometric primitive line or area OR any feature object where WATLEV/watlev is Equal to 1 (partly submerged at high water) OR 2 (always dry).	RECTRC intersects non-navigational objects.	Amend RECTRC or other objects to ensure RECTRC is within navigable objects.	Logical consistency	E
64	For each achare feature object which is COVERED_BY OR OVERLAPS another feature object where RESTRN or restrn includes the value 1 (anchoring prohibited).	achare object within an area with RESTRN <u>or</u> restrn = 1 (anchoring prohibited).	Amend achare object or object carrying RESTRN <u>or</u> restrn = 1 (anchoring prohibited).	Logical consistency	W
65	For each LIGHTS feature object which EQUALS another LIGHTS feature object AND STATUS does Not contain the value 4 (not in use) where sectors overlap AND none of the values of the following attributes are different CATLIT, EXCLIT, LITCHR, SIGPER or SIGGRP.	Coincident lights with overlapping sectors and the same characteristics.	Amend light sectors so that they do not overlap, or remove duplicated sectors.	Logical consistency	W
	<i>Check removed.</i>				
67a	For each feature object where the object class, attribution and geometry is identical to another feature object.	Duplicate object exists.	Remove duplicate object.	Data structure	E

No.	Check description	Check message	Check solution	Conformity to:	Cat.
67b	For each collection object which references exactly the same set of feature objects as another collection object.	Duplicate collection object exists.	Remove duplicate collection object.	Data structure	E
	<i>Check renumbered 1007.</i>				
	<i>Check removed.</i>				
	<i>Check removed.</i>				
	<i>Check removed.</i>				
71a	For each feature object of geometric primitive area that is not COINCIDENT with the M_COVR boundary where all edges are masked (i.e. USAG is Equal to 3 (exterior boundary truncated by the data limit) OR MASK is Equal to 1 (mask)).	Area object has all of its edges masked and is not the edge of the data coverage.	Remove masking.	Logical consistency	W
71b	For each feature object of geometric primitive line which has any edges masked (i.e. MASK is Equal to 1 (mask)).	Line object with masked edges.	Remove masking from line object.	Logical consistency	E
72	For each set of hierarchical relationships which form a loop (e.g. master object is slave of its own slave).	Relationships form a loop.	Amend relationships to remove loop.	Logical consistency	E
73a	For each attribute value which contains a leading or trailing space.	Attribute value contains leading or trailing spaces.	Remove leading or trailing spaces.	Logical consistency	W
73b	For each attribute value of type list which contains spaces.	List attribute value contains spaces.	Remove spaces.	Logical consistency	W
74	For each DEPCNT feature object which does not share an edge with a Group 1 feature object AND is WITHIN a DEPART feature object of geometric primitive area where DRVAL1 and DRVAL2 are notNull AND VALDCO is Less than DRVAL1 OR Greater than DRVAL2.	Floating DEPCNT within a DEPART with VALDCO less than DRVAL1 or greater than DRVAL2.	Amend floating contour VALDCO between DRVAL1 and DRVAL2 of the underlying DEPART.	Logical consistency	C

No.	Check description	Check message	Check solution	Conformity to:	Cat.
75	For each DEPCNT feature object which does not share an edge with a Group 1 feature object AND is WITHIN a DRGARE feature object of geometric primitive area where DRVAL1 is notNull AND VALDCO is Less than DRVAL1.	Floating DEPCNT within a DRGARE with VALDCO less than DRVAL1 of the DRGARE.	Amend floating contour VALDCO to be greater than the DRVAL1 of the underlying DRGARE or amend DRVAL1 of the DRGARE.	Logical consistency	C
76	For each DEPCNT feature object that CROSSES OR is WITHIN a FLODOC, flodoc, HULKES, hulkes, LNDARE or PONTON or ponton feature object of geometric primitive area.	DEPCNT crosses or is within prohibited objects.	Amend DEPCNT to be within appropriate objects.	Logical consistency	E
77	For each DEPCNT feature object which CROSSES another DEPCNT feature object.	DEPCNT objects cross.	Amend DEPCNT objects so they do not cross.	Logical consistency	C
78	For each feature object of geometric primitive area where its boundary crosses itself.	Boundary of an area object crosses itself.	Amend boundary to remove part which crosses itself.	Logical consistency	C
79	For each feature object of geometric primitive line where a component edge CROSSES another component edge without a connected node at the crossing point.	Component edges of a line object cross without a connected node at the crossing point.	Insert connected node at crossing point.	Topology	E
80a	For each feature object of geometric primitive area where an interior boundary is WITHIN an interior boundary.	Interior boundary within an interior boundary.	Amend boundaries so that interior boundary is not within another interior boundary.	Topology	C
80b	For each feature object of geometric primitive area where an interior boundary is not WITHIN an exterior boundary.	Interior boundary outside of an exterior boundary.	Amend boundaries so that interior boundary is within exterior boundary.	Topology	C

No.	Check description	Check message	Check solution	Conformity to:	Cat.
80c	For each feature object of geometric primitive area where an exterior boundary is WITHIN an interior boundary.	Exterior boundary within an interior boundary.	Amend boundaries so that exterior boundary is not within the interior boundary.	Topology	C
81	For each Spot Sounding (point of sounding array) which position EQUALS another spot sounding. (EQUALS applies to the horizontal component only).	Spot Soundings position is equal.	Remove coincident sounding.	Topology	E
82	For each feature object of geometric primitive line or area which references the same edge more than once.	Object references the same edge more than once.	Remove duplicate reference to the edge.	Topology	C
83	For each node which EQUALS another node (connected or isolated).	Nodes are coincident.	Remove or amend coincident node.	Topology	W
84a	For each node which is physically isolated AND is marked as connected.	Isolated node marked as connected.	Amend to isolated node.	REF#IHO-S57 Part 3 (5.1.1)	C
84b	For each node which is not physically isolated AND is marked as isolated.	Connected node marked as isolated.	Amend to connected node.	REF#IHO-S57 Part 3 (5.1.1)	C
	<i>Check renumbered 1008.</i>				
86	For each feature object of geometric primitive point which references more than one vector record.	Point feature references more than one vector record.	Remove references to additional vector records.	REF#IHO-S57 Part 3 (4.7.1)	C
87	For each edge with EQUAL consecutive vertices.	Consecutive vertices are coincident.	Remove coincident vertices from edge.	REF#IHO-S57 Part 3 (4.7.2)	E
88a	For each feature object of geometric primitive area where ORNT is Not equal to 1 (forward) AND is Not equal to 2 (reverse).	Invalid value of ORNT.	Set value of ORNT to 1 (forward) or 2 (reverse).	REF#IHO-S57 Part 3 (4.7.3)	C

No.	Check description	Check message	Check solution	Conformity to:	Cat.
88b	For each feature object of geometric primitive area where USAG is Not equal to 1 (exterior) AND is Not equal to 2 (interior) AND is Not equal to 3 (exterior boundary truncated by the data limit).	Invalid value of USAG.	Set USAG to 1 (exterior), 2 (interior) or 3 (exterior boundary, truncated by the data limit).	REF#IHO-S57 Part 3 (4.7.3)	C
88c	For each feature object of geometric primitive area where MASK is Not equal to 1 (mask) AND is Not equal to 2 (show) AND is Not equal to 255 (masking is not relevant).	Invalid value of MASK.	Set MASK to 1 (mask), 2 (show) or 255 (masking is not relevant).	REF#IHO-S57 Part 3 (4.7.3)	C
89a	For each master object which references the same slave more than once.	Master object references the same slave more than once.	Remove duplicate reference to slave object.	REF#IHO-S57 Part 3 (6.3); Annex 1(3.9)	C
89b	For each slave object which is referenced by more than one master object.	Slave object has more than one master.	Remove incorrect master from slave object.	REF#IHO-S57 Part 3 (6.3); Annex 1 (3.9)	C
	<i>Check renumbered 1009</i>				
90b	For an EN file where the DDR does not contain only the description of the base cell file structure.	Invalid DDR in EN file.	Amend DDR.	REF#IHO-S57 Part 3 (7) and Part 3 (A.2)	W
90c	For an ER file where the DDR does not contain only the description of the update cell file structure.	Invalid DDR in ER file.	Amend DDR.	REF#IHO-S57 Part 3 (7) and Part 3 (A.2)	W
	<i>Check removed.</i>				
	<i>Check renumbered 1010.</i>				
93a	For each feature object of geometric primitive area where WATLEV is Equal to 4 (covers and uncovers) OR 5 (awash) or watlev is Equal to 4 (covers and uncovers) AND OVERLAPS OR is WITHIN a LNDARE feature object of geometric primitive area.	Object with WATLEV = 4 or 5 or watlev = 4_is within a LNDARE object.	Amend LNDARE object to ensure object is within an intertidal area.	Logical consistency	E

No.	Check description	Check message	Check solution	Conformity to:	Cat.
93b	For each feature object of geometric primitive point where WATLEV is Equal to 4 (covers and uncovers) OR 5 (awash) or watlev is Equal to 4 (covers and uncovers) AND is COVERED_BY a LNDARE feature object.	Object with WATLEV = 4 or 5 or watlev = 4_on a LNDARE object.	Amend LNDARE object to ensure object is within an intertidal area.	Logical consistency	E
93c	For each feature object of geometric primitive line where WATLEV is Equal to 4 (covers and uncovers) OR 5 (awash) or watlev is Equal to 4 (covers and uncovers) AND CROSSES OR is WITHIN a LNDARE feature object of geometric primitive area.	Object with WATLEV = 4 or 5 or watlev = 4 is within a LNDARE object.	Amend LNDARE object to ensure object is within an intertidal area.	Logical consistency	E
94	For each ER file which contains instructions for the FSPC field to modify an FSPT field of a feature object to a value it already contains.	ER file contains instructions to modify an FSPT field to a value it already contains.	Remove irrelevant FSPC field from ER file.	Logical consistency	E
95	If the COMT subfield of the DSID and DSPM fields contains text which is not lexical level (0).	COMT subfield contains text which is not lexical level (0).	Amend text to conform to lexical level (0).	REF#IHO-S57 Part 3 (2.4)	E
96	For each relationship which does not reference a C_ASSO or C_AGGR collection object AND the RIND subfield of the FFPT field is set to 3 (peer).	Invalid value of RIND.	Amend the relationship indicator to 2 (slave) or remove as appropriate.	REF#IHO-S57 Part 3 (6.2) and Annex 1(3.9)	E
97	For each feature object where SUREND and SURSTA are notNull AND SUREND is Less than SURSTA.	SUREND less than SURSTA.	Ensure SURSTA is earlier than SUREND.	Logical consistency	E
98	For each feature object which has a relationship AND references an object which does not exist.	Object references an object that does not exist	Remove reference to non-existent object	Logical consistency	E

3.2 Checks relating to the Annex 1

No.	Check description	Check message	Check solution	Conformity to:	Cat.
500	For each feature object where its geometry is not COVERED_BY a M_COVR meta object with CATCOV Equal to 1 (coverage available).	Objects fall outside the coverage object.	Ensure objects are not outside of the limits of the coverage area for the cell.	Annex 1, Appendix 2, C.1.1 A)	C
501	<i>Not applicable for IENCs</i>				
502	If the cell file size is greater than 5 Megabytes.	The cell is larger than 5 MB in size.	Ensure that the cell is not larger than 5 MB.	2.2	E
503	For each feature object where the FOID is not unique WITHIN the dataset.	Duplicate FOIDs exist within the dataset.	Ensure that no duplicate FOIDs exist.	3.1	W
504	For each prohibited feature object for IENCs.	Prohibited objects exist within the dataset.	Remove prohibited objects.	3.2	C
505	If either M_COVR or m_nsys_meta objects do not exist within the data set.	Mandatory feature objects are missing.	Include mandatory feature objects M_COVR and m_nsys.	3.4 and Annex 1, Appendix 2	C
	<i>Check removed.</i>				
507	If any mandatory attributes are not Present.	Mandatory attributes are not encoded.	Populate mandatory attributes (If unknown encode attribute with empty value).	3.5.2 and Annex 1, Appendix 2 and Annex 1, Appendix 1	C
508a	For each feature object (excluding LIGHTS) where more than one value of COLOUR is encoded AND COLPAT is not Present OR is Null.	COLOUR has multiple values without a value for COLPAT.	Ensure COLPAT has a value where multiple COLOUR values are encoded.	3.5.2 and Logical consistency	E
508b	For each feature object where COLPAT is notNull AND COLOUR is Null OR only has one value.	COLPAT is populated without multiple COLOUR values.	Ensure multiple COLOUR values are populated or remove COLPAT value.	3.5.2 and Logical consistency	E

No.	Check description	Check message	Check solution	Conformity to:	Cat.
509	For each feature object listed below where the attribute stated is Null: CTNARE: INFORM; DEPART: DRVAL1 and DRVAL2; depart: DRVAL1 and DRVAL2; DEPCNT: VALDCO; M_COVR: CATCOV; m_nsys: marsys; m_sdat: verdatm_vdat: verdat; MAGVAR: VALMAG; NEWOBJ: CLSDEF and CLSNAM; RCTLPT: ORIENT; RESARE: RESTRN; resare: restrn.	Mandatory attribute has not been populated with a value.	Populate mandatory attributes; in these cases the object is meaningless without this value.	3.5.2 and Annex 1, Appendix 2 and Annex 1, Appendix 1	E
	<i>Check removed.</i>				
511	<i>3.5.3, prohibited attributes, is not applicable for IENCs according to Annex 1.</i>				
512	For each feature object with an attribute of type Float or Integer where the value contains zeroes before the first numerical digit or after the last numerical digit.	Values have been padded with nonsignificant zeroes. Example: For a signal period of 2.5 sec, the value of SIGPER must be 2.5 and not 02.500.	Remove nonsignificant zeroes.	3.5.4	E
513	For each feature object with an attribute value identical to a corresponding attribute of a meta object it is COVERED_BY.	An attribute value of a meta object is duplicated on a geo object.	Remove duplicate value from geo object.	3.5.6	E
	<i>Check removed.</i>				
515	For each edge where the subfield USAG (Usage indicator) is Equal to 3 (exterior boundary, truncated by the data limit) AND the MASK subfield is Not equal to 255 (masking is not relevant).	Edge with USAG = 3 (exterior boundary truncated by the data limit) does not have MASK = 255 (masking is not relevant).	Set MASK to 255 (masking is not relevant) for edges with USAG = 3.	3.8	W
516a	For each master feature object of geometric primitive point which does not share the geometry of the related slave objects.	Master and slave point objects do not share the same node.	Ensure master and slave point objects share the same node.	3.9	E

No.	Check description	Check message	Check solution	Conformity to:	Cat.
516b	For each master feature object of geometric primitive line where the slave object does not INTERSECT the master object.	Slave object is not located on the master line object.	Ensure the master and slave objects overlap.	3.9	E
516c	For each master feature object of geometric primitive area where the slave object is not COVERED_BY the master object.	Slave object is not covered by the master area object.	Ensure the slave object covered by the master object.	3.9	E
517a	For each collection feature object which does not reference at least two feature objects.	Collection feature object does not reference at least two feature objects.	Remove collection feature object or ensure that it references at least two feature objects.	3.9 and Part 3 (6.2)	E
517b	For each collection feature object which references itself.	Collection feature object references itself.	Remove circular reference.	3.9 and Part 3 (6.2)	E
517c	For each collection feature object where the subfield PRIM is Not equal to Null (255) (no geometry).	Invalid value of geometric primitive subfield.	Set PRIM subfield to Null (255) (no geometry).	3.9 and Part 3 (6.2)	E
	<i>Check removed.</i>				
517e	For each collection feature object where the RIND subfield is not 3 (peer) OR which references feature objects where the subfield RIND is Not equal to 3 (peer).	Collection feature object which is peer, references non-peer feature objects.	Amend feature objects to peer.	3.9 and Part 3 (6.2)	E
517f	For each collection feature object that references the same feature more than once.	Collection feature object contains multiple references to the same feature object.	Remove duplicate reference.	3.9 and Part 3 (6.2)	E
518a	For each FLODOC, DRGARE, LNDARE, HULKES, PONTON, DEPARE, depare or UNSARE feature object of geometric primitive area where the GRUP subfield of the FRID is Not equal to 1 (Group 1).	Skin of the earth objects are not encoded as Group 1.	Ensure that the FRID subfield GRUP is set to 1 (Group 1) for all skin of the earth feature objects.	3.10.1	C

No.	Check description	Check message	Check solution	Conformity to:	Cat.
518b	For each feature object (excluding FLODOC, DRGARE, LNDARE, HULKES, PONTON, DEPARE, depare and UNSARE of geometric primitive area) where the GRUP subfield of the FRID is Not equal to 2 (Group 2).	Group 2 objects are not encoded as Group 2.	Ensure that the FRID subfield GRUP is set to 2 (Group 2) for all non-skin of the earth feature objects.	3.10.2	C
519a	If the combined coverage of all DEPARE, depare, DRGARE, FLODOC, HULKES, LNDARE, PONTON and UNSARE feature objects is Not equal to the combined coverage of all M_COVR meta objects where CATCOV is Equal to 1 (coverage available).	Skin of the earth (Group1) objects do not cover the data coverage (M_COVR = 1).	Amend Group1 object limits to match data coverage.	3.10.1	C
519b	For each DEPARE, depare, DRGARE, FLODOC, HULKES, LNDARE, PONTON or UNSARE, feature object of geometric primitive area that OVERLAPS or is WITHIN another DEPARE, depare, DRGARE, FLODOC, HULKES, LNDARE, PONTON or UNSARE of geometric primitive area.	Skin of the earth (Group1) objects overlap.	Ensure Group 1 objects do not overlap.	3.10.1	C
520a	If the AALL subfield of the DSSI is Not equal to 0 AND is Not equal to 1.	Invalid value of AALL.	Set value of AALL to 0 or 1.	6.3.2.2 and 6.4.2.2	E
520b	If the NALL subfield of the DSSI is Not equal to 0 AND is Not equal to 1 AND is Not equal to 2.	Invalid value of NALL.	Set value of NALL to 0, 1 or 2.	6.3.2.2 and 6.4.2.2	E
	<i>Check removed.</i>				
520d	If lexical level 2 has been used anywhere other than the NATF field.	Lexical level 2 used outside of the NATF field. (Return character sets used and the sequence found.)	Amend text to remove lexical level 2 characters.	3.11 and 3.5.5	E

No.	Check description	Check message	Check solution	Conformity to:	Cat.
520e	If any ATTF or NATF field contains characters of a lexical level greater than that in the DSSI-AALL/NALL subfields correspondingly.	Lexical level of characters in the attribute or encoding of DSSI-AALL/NALL is inconsistent.	Amend characters or the subfield encoding as required.	3.11 and 3.5.5	E
520f	If the UT or FT is not encoded at the lexical level specified for that field.	The UT or FT is not of the correct lexical level.	Amend UT and FT to the correct lexical level.	REF#IHO-S57 Part 3, Annex B (B.2)	E
	<i>Check removed.</i>				
	<i>Check removed.</i>				
521a	For each feature object where OBJNAM and NOBJNM are notNull AND are Equal.	Values for OBJNAM and NOBJNM are identical.	Ensure that national language attributes are populated with the correct values.	3.11.1	W
521b	For each feature object where INFORM and NINFOM are notNull AND are Equal.	Values for INFORM and NINFOM are identical.	Ensure that national language attributes are populated with the correct values.	3.11.1	W
521c	For each feature object where PILDST and NPLDST are notNull AND are Equal.	Values for PILDST and NPLDST are identical.	Ensure that national language attributes are populated with the correct values.	3.11.1	W
521d	For each feature object where TXTDSC and NTXTDS are notNull AND are Equal.	Values for TXTDSC and NTXTDS are identical.	Ensure that national language attributes are populated with the correct values.	3.11.1	W
522	For each feature object where NOBJNM is notNull AND OBJNAM is Null OR not Present.	NOBJNM is populated without OBJNAM.	Populate OBJNAM.	3.11.1	E
523	If the HDAT subfield of the DSPM field is Not equal to 2 (WGS 84).	HDAT does not equal 2 (WGS 84).	Set the HDAT subfield to 2 (WGS 84).	4.1	C
524	If the DUNI subfield of the DSPM field is Not equal to 1 (metres).	DUNI does not equal 1 (metres).	Set the DUNI subfield to 1 (metres).	4.4	C
525	If the PUNI subfield of the DSPM is Not equal to 1 (metres).	PUNI does not equal 1 (metres).	Set the PUNI subfield to 1 (metres).	4.4	C

No.	Check description	Check message	Check solution	Conformity to:	Cat.
526	If the COUN subfield of the DSPM field is Not equal to 1 (latitude/longitude).	COUN does not equal 1 (latitude/longitude).	Set the COUN subfield to 1 (latitude/longitude).	4.4 and 6.2.2.3	C
	<i>Check renumbered 1011.</i>				
	<i>Check renumbered 1012.</i>				
	<i>Check renumbered 1013.</i>				
	<i>Check renumbered 1014.</i>				
531	If the Dataset file name is not in accordance with the Annex 1.	Dataset file name is not in accordance with the Annex 1.	Amend file names.	5.6.3	C
	<i>Check renumbered 1015.</i>				
533	If the UADT subfield of the DSID field is used in an ER file.	DSID-UADT subfield populated in an ER file.	Remove value of DSID-UADT subfield.	5.7	C
534	If a delete cell message contains anything other than the DSID field AND EDTN is Equal to 0.	Incorrect delete cell message.	Remove additional information from delete cell message.	5.7	C
	<i>Check renumbered 1016.</i>				
536	If a field without a repetition factor repeats.	Field without a repetition factor repeats.	Remove repeating value.	6.1.3	C
	<i>Check renumbered 1017.</i>				
	<i>Check renumbered 1018.</i>				
539	If DSID-PROF is Not equal to 1 (EN) AND is Not Equal to 2 (ER).	Invalid value of DSID-PROF.	Set DSID-PROF to either 1 (EN) or 2 (ER).	6.3 and 6.4 and REF#IHO-S57 Part 3 (7.3.1.1)	C
540a	If mandatory records, fields and subfields are not Present OR are Null where the "Null" value is not allowed.	Mandatory records, fields or subfields are not used.	Add mandatory records/values.	6.1.4, 6.3 and 6.4	C
540b	If data set file contains prohibited records, fields or subfields.	Prohibited records, fields or subfields used.	Remove prohibited records/values.	6.3 and 6.4	C

No.	Check description	Check message	Check solution	Conformity to:	Cat.
	<i>Check removed.</i>				
541b	For each LIGHTS feature object where LITCHR is Not Equal to 1 (Fixed) where SIGGRP does not start and finish with a bracket.	SIGGRP is incorrectly formatted.	Ensure SIGGRP is correctly formatted with appropriate brackets.	Annex 1, Appendix 2	E
542	For each FOGSIG and RTPBCN feature object where SIGGRP is Present AND does not start and finish with a bracket.	SIGGRP is not formatted correctly.	Amend the formatting of SIGGRP.	Annex 1, Appendix 2	E
	<i>Check removed.</i>				
543a	<i>No TS_TSP in Annex 1, Appendix 1.</i>				
543b	<i>No TS_TSP in Annex 1, Appendix 1.</i>				
543c	<i>No TS_TSP in Annex 1, Appendix 1.</i>				
543d	<i>No TS_TSP in Annex 1, Appendix 1.</i>				
543e	<i>No TS_TSP in Annex 1, Appendix 1.</i>				
543f	<i>No TS_TSP in Annex 1, Appendix 1.</i>				
544	For each feature object that OVERLAPS, CROSSES OR is WITHIN an area of M_COVR where CATCOV is Equal to 2 (no coverage available).	Object within an area of no coverage.	Remove object or amend coverage.	2.2 and Annex 1, Appendix 2 C.1.1	C
545	For each feature object which does not have a valid feature object class label/code as defined by the Annex 1, Appendix 1.	Object has invalid object class code.	Amend object class code.	3.2 and Annex 1, Appendix 1	C
546	For each attribute which does not have a valid attribute label/code as defined by the Annex 1, Appendix 1	Attribute has invalid attribute label/code.	Amend attribute label/code.	3.2 and Annex 1, Appendix 1	C
547	For each feature object which contains attributes outside the list of permissible attributes for the feature object as defined in the Annex 1, Appendix 1.	Attribute not permitted on feature object class.	Remove attribute.	3.2 and Annex 1, Appendix 1	C

No.	Check description	Check message	Check solution	Conformity to:	Cat.
548	If the combined coverage of M_COVR meta objects is Not equal to the cell extents in an IENC of the USA or the Russian Federation.	Cell not entirely covered by M_COVR objects.	Edit M_COVR coverage to match cell extents in IENCs of the USA and Russian Federation.	Annex 1, Appendix 2 C.1.1	C
549	For each DEPARE, depare or DRGARE feature object which is not COVERED_BY the combined coverage of M_QUAL meta objects in an IENC of the USA or the Russian Federation.	DEPARE or DRGARE objects not covered by an M_QUAL object.	Ensure full coverage of M_QUAL objects over DEPARE or DRGARE objects in IENCs of the USA and Russian Federation.	Annex 1, Appendix 2 C.1.2	E
550	For each UNSARE feature object which COVERS OR CROSSES OR OVERLAPS the following objects DEPCNT, OBSTRN, SOUNDG, UWTRC, uwtrc or WRECKS AND is not COVERED_BY the combined coverage of M_QUAL meta objects in an IENC of the USA or the Russian Federation.	UNSARE containing bathymetric features not completely covered by M_QUAL.	Ensure M_QUAL objects completely cover UNSARE objects containing bathymetric features in IENCs of the USA and Russian Federation.	Annex 1, Appendix 2 C.1.2	E
551a	If text attribute values use (C0) characters (C0 as defined in REF#IHO-S57 Part 3, Annex B).	C0 characters used in text attribute values.	Correct text attribute values.	3.5.5 and REF#IHO-S57 Part 3 Annex B	E
551b	If the delete character is used outside of the update mechanism, (i.e. in records where RUIN is Equal to 3 (modify)).	Delete character used outside of the update mechanism.	Only use delete within the update mechanism.	3.5.5	E
	<i>Check removed.</i>				
553	For each Group 1 feature object where any of DATSTA, DATEND, PERSTA or PEREND is Present AND notNull.	Attributes DATSTA, DATEND, PERSTA or PEREND are encoded on Group 1 objects.	Remove these attributes from Group 1 objects.	3.10.1 and logical consistency	C

No.	Check description	Check message	Check solution	Conformity to:	Cat.
554	For each edge referenced by only one M_COVR meta object where CATCOV is Equal to 1 (coverage available) AND is also shared by more than one Group 1 feature object.	Edge of M_COVR (coverage available) referenced by more than one Group 1 object.	Ensure edges on the extent of data coverage only reference one Group 1 object.	3.10.1	C
555	If the order of the data in a base or update file is not correct.	Incorrect data order.	Amend data order.	6.1.1	C
	<i>Check renumbered 1024a.</i>				
	<i>Check renumbered 1024b.</i>				
557	For each SIGSEQ attribute value which does not conform to the correct structure (i.e. string content is not in accordance with format specification).	SIGSEQ attribute not formatted correctly.	Amend formatting of SIGSEQ attribute value.	Annex 1, Appendix 2 and Annex 1, Appendix 1	E
558	For each feature object where SIGSEQ is notNull AND SIGPER is Not equal to the sum of the intervals of light and eclipse given in SIGSEQ.	SIGPER does not correspond to SIGSEQ.	Ensure SIGPER corresponds to the sum of the intervals of light and eclipse given in SIGSEQ.	Annex 1, Appendix 2 and logical consistency	E
559a	For each feature object where STATUS includes the value 1 (permanent) in combination with at least one of 2 (occasional), 5 (periodic/intermittent) or 7 (temporary).	Illogical combination of STATUS values.	Amend values for STATUS.	Annex 1, Appendix 2 and logical consistency	E
559b	For each feature object where STATUS includes the value 3 (recommended) in combination with at least one of 4 (not in use) or 11 (extinguished).	Illogical combination of STATUS values.	Amend values for STATUS.	Annex 1, Appendix 2 and logical consistency	E
559c	For each feature object where STATUS includes the value 4 (not in use) in combination with at least one of 5 (periodic/intermittent) or 9 (mandatory).	Illogical combination of STATUS values.	Amend values for STATUS.	Annex 1, Appendix 2 and logical consistency	E
559d	For each feature object where STATUS includes the value 5 (periodic/intermittent) in combination with 11 (extinguished).	Illogical combination of STATUS values.	Amend values for STATUS.	Annex 1, Appendix 2 and logical consistency	E

No.	Check description	Check message	Check solution	Conformity to:	Cat.
559e	For each feature object where STATUS includes the value 9 (mandatory) in combination with 11 (extinguished).	Illogical combination of STATUS values.	Amend values for STATUS.	Annex 1, Appendix 2 and logical consistency	E
559f	For each feature object where STATUS includes the value 16 (watched) in combination with 17 (unwatched).	Illogical combination of STATUS values.	Amend values for STATUS.	Annex 1, Appendix 2 and logical consistency	E
559g	For each feature object where STATUS includes the value 8 (private) in combination with 14 (public).	Illogical combination of STATUS values.	Amend values for STATUS.	Annex 1, Appendix 2 and logical consistency	E
560a	For all feature objects with the same FOID where the object class and attribute values are not identical.	Objects with the same FOID do not have the same feature encoding.	Ensure objects with the same FOID have the same object class and attribute values.	3.1	C
560b	For all feature objects with the same FOID where the geometric primitives are Point OR are not of the same geometric primitive.	Objects with the same FOID are of geometric primitive point or have different geometric primitives.	Ensure point objects do not have the same FOID and that line and area objects which share FOIDs have the same geometric primitive.	3.1	C
	<i>Check removed.</i>				
562	For each NEWOBJ feature object where INFORM does not commence with the CLSNAM AND contain the CLSDEF of the feature object.	The text in INFORM does not commence with the CLSNAM object or contain the CLSDEF of the NEWOBJ feature object.	Ensure that the text in INFORM commences with the CLSNAM followed by the CLSDEF of the NEWOBJ feature object.	Annex 1, Appendix 2 O.1.11	W
	<i>Check removed.</i>				
	<i>Check removed.</i>				
	<i>Check removed.</i>				

No.	Check description	Check message	Check solution	Conformity to:	Cat.
556	For each NEWOBJ feature object with the attributes CLSDEF, CLSNAM and SYMINS not populated with exactly one of the following combinations:	Invalid use of NEWOBJ.	Amend to reflect encoding guidance.	Annex 1, Appendix 2, O.1.11	C
	CLSDEF	CLSNAM	SYMINS		
	A Virtual object which indicates navigable water lies northwards	Virtual AtoN, North Cardinal	SY(BRTHNO01);SY(BCNCAR01);TX('V-AIS',3,2,2,'15110',2,0,CHMGD,11)		
	A Virtual object which indicates navigable water lies eastwards	Virtual AtoN, East Cardinal	SY(BRTHNO01);SY(BCNCAR02);TX('V-AIS',3,2,2,'15110',2,0,CHMGD,11)		
	A Virtual object which indicates navigable water lies southwards	Virtual AtoN, South Cardinal	SY(BRTHNO01);SY(BCNCAR03);TX('V-AIS',3,2,2,'15110',2,0,CHMGD,11)		
	A Virtual object which indicates navigable water lies westwards	Virtual AtoN, West Cardinal	SY(BRTHNO01);SY(BCNCAR04);TX('V-AIS',3,2,2,'15110',2,0,CHMGD,11)		
	A Virtual object marking the port side of a channel	Virtual AtoN, Port Lateral	SY(BRTHNO01);SY(BOYLAT24);TX('V-AIS',3,2,2,'15110',2,0,CHMGD,11)		
	A Virtual object marking the starboard side of a channel	Virtual AtoN, Starboard Lateral	SY(BRTHNO01);SY(BOYLAT13);TX('V-AIS',3,2,2,'15110',2,0,CHMGD,11)		
	A Virtual object marking the port side of a channel	Virtual AtoN, Port Lateral	SY(BRTHNO01);SY(BOYLAT23);TX('V-AIS',3,2,2,'15110',2,0,CHMGD,11)		
	A Virtual object marking the starboard side of a channel	Virtual AtoN, Starboard Lateral	SY(BRTHNO01);SY(BOYLAT14);TX('V-AIS',3,2,2,'15110',2,0,CHMGD,11)		
	A Virtual object marking an isolated danger	Virtual AtoN, Isolated Danger	SY(BRTHNO01);SY(BCNISD21);TX('V-AIS',3,2,2,'15110',2,0,CHMGD,11)		
	A Virtual object marking safe water	Virtual AtoN, Safe Water	SY(BRTHNO01);SY(BOYSAW12);TX('V-AIS',3,2,2,'15110',2,0,CHMGD,11)		
	A Virtual object used to mark an area or feature referred to in nautical documents	Virtual AtoN, Special Purpose	SY(BRTHNO01);SY(BOYSPP11);TX('V-AIS',3,2,2,'15110',2,0,CHMGD,11)		
A Virtual object marking a wreck	Virtual AtoN, Wreck Marking	SY(BRTHNO01);SY(BOYSPP11);TX('V-AIS',3,2,2,'15110',2,0,CHMGD,11)			

No.	Check description	Check message	Check solution	Conformity to:	Cat.
567	For each attribute of type 'list' (excluding COLOUR, NATQUA and NATSUR) with more than one instance of the same value.	List attribute contains the same value more than once.	Remove unnecessary attribute value.	Logical consistency	E
568	For each feature object where PERSTA and PEREND are notNull AND their values are identical.	Object has identical values of PERSTA and PEREND.	Ensure values of PERSTA and PEREND are logical.	Logical consistency	E
569	For each feature object where PERSTA is notNull AND PEREND is Null OR not Present.	Object has PERSTA without a value of PEREND.	Populate PEREND or remove PERSTA.	Logical consistency	E
570	For each feature object where PEREND is notNull AND PERSTA is Null OR not Present.	Object has PEREND without a value of PERSTA.	Populate PERSTA or remove PEREND.	Logical consistency	E
571	For each edge which contains vertices at a density Greater than 0.3 mm at compilation scale.	Vertex density exceeds the allowable tolerance.	Generalise edge(s).	3.8	W
572	For each feature object where NINFOM is notNull AND INFORM is Null OR not Present.	NINFOM is populated without INFORM.	Populate INFORM.	3.11.1 and Annex 1, Appendix 2	E
573	For each feature object where NPLDST is notNull AND PILDST is Null OR not Present.	NPLDST is populated without PILDST.	Populate PILDST.	3.11.1 and Annex 1, Appendix 2	E
574	For each feature object where NTXTDS is notNull AND TXTDSC is Null OR not Present.	NTXTDS is populated without TXTDSC.	Populate TXTDSC and include relevant text file.	3.11.1 and Annex 1, Appendix 2	E
575	If the DSTR subfield of the DSSI field is Not equal to 2 (chain node).	DSTR does not equal 2.	Set the DSTR subfield to 2 (chain node).	6.3.2.2 and 6.4.2.2	C
576	For each M_QUAL meta object which OVERLAPS or is WITHIN another M_QUAL meta object.	M_QUAL objects overlap.	Amend objects to remove overlap.	3.4 and Annex 1, Appendix 2	E

3.3 Exchange Set Level Checks

No.	Check description	Check message	Check solution	Conformity to:	Cat.
	<i>Check removed.</i>				
	<i>Check removed.</i>				
	<i>Check removed.</i>				
	<i>Check removed.</i>				
	<i>Check removed.</i>				
	<i>Check removed.</i>				
1006	If an update and its base cell do not have the same lexical level.	Update and base cell do not have the same lexical level.	Amend the lexical level of the update.	3.5.5 and REF#IHO-S57 Part 3 (8.4.2.2a)	C
	<i>Check removed.</i>				
1008	For each ER (update) file where an AGEN subfield value of the DSID field or FOID field is not identical to the AGEN subfield values in the EN (base) file.	AGEN subfield values do not agree between ER (update) and EN (base) files.	Amend AGEN subfield values to agree.	5.6.3 and REF#IHO-S57 Part 3 (4.3.1) and (7.3.1.1)	C
1009	For a catalogue file where the DDR does not contain only the description of the catalogue file structure.	Invalid DDR in catalogue file.	Amend DDR.	REF#IHO-S57 Part 3 (7) and Part 3 (A.2)	W
1010	For each FRID field in an ER (update) file where RUIN is Equal to 3 (modify) AND the FOID for the modified object is not identical in the EN (base) and ER (update) files.	FOID for the modified object is not identical in the EN (base) and ER (update) files.	Amend FOIDs to be identical or make separate insert and delete updates.	REF#IHO-S57 Part 3 (8.4.2)	C
1011	For each feature object where TXTDSC, NTXTDS, PICREP is 'notNull' and references a file that is Not present in the exchange set OR their names do not conform to the Annex 1.	Text or picture file referenced by a feature object is not present in the exchange set or its name is nonconformant.	Ensure referenced files exist and are named correctly.	5.4.1 and 5.6.4; Annex 1, Appendix 2, B – General Guidance	C
1012	If a catalogue file does not exist.	No catalogue file exists.	Create a catalogue file.	5.4.1	C

No.	Check description	Check message	Check solution	Conformity to:	Cat.
1013	If volume name is not in accordance with the Annex 1.	Volume name is not in accordance with the Annex 1.	Amend the volume name.	5.4.2	C
1014	If the directory structure for physical media is not in accordance with the Annex 1.	The directory structure for physical media is not in accordance with the Annex 1.	Correct the directory structure of the physical media.	5.4.3	C
1015	If the text and picture file names are not in accordance with the Annex 1.	Text and picture file names have incorrect format/name.	Use correctly formatted and named text and picture files.	5.6.4 and Annex 1, Appendix 2	C
1016	If the calculated CRC value of a file is Not equal to that stated in the catalogue file.	CRC values do not match.	Amend CRC value.	5.9.1	C
1017	If the format of the catalogue file is not correct.	Catalogue file format not correct.	Amend format of the catalogue file.	6.2	C
1018	If the IMPL subfield of the CATD field is Not equal to "BIN" for the data set file.	CATD-IMPL is not equal to "BIN".	Amend CATD-IMPL.	5.1 and 6.2.2	E
1019	For each feature object where TXTDSC AND NTXTDS are notNull AND the files referenced are identical or empty.	Files referenced by TXTDSC and NTXTDS are the same or empty.	Ensure files are different.	Logical consistency	W
	<i>Check removed.</i>				
1021a	If the data set is not a reissue AND the UPDN subfield is not equivalent to the extension of the data set file name.	Update number is incorrect or not equivalent to the data set file name extension.	Amend UPDN subfield.	5.7	C
	<i>Check removed.</i>				
	<i>Check removed.</i>				
1023	<i>Other file formats are allowed for IENCs</i>				

No.	Check description	Check message	Check solution	Conformity to:	Cat.
1024a	For a base cell file if the limits contained in the subfields SLAT, WLON, NLAT, and ELON of the CATD field of the catalogue file are Not equal to the furthest coordinates of the M_COVR meta object in the corresponding base cell file.	Limits in catalogue do not correspond to M_COVR limits for a base cell file.	Amend limits in catalogue or base cell file M_COVR object to agree.	Appendix B.1 (5.6.3 and 6.2.2) and logical consistency	C
1024b	For an update cell file if the limits are not identical to the limits of the base cell to which they apply.	Update with limits different to that of the base cell.	Amend limits of update file.	5.6.3 and 6.2.2 and logical consistency	C
i1001	For external files in an exchange set that are not referenced by a dataset in the same exchange set	External file not referenced by a dataset in the exchange set	Delete external file	Annex 1 and Annex 1, Appendix 2	E

3.4 Checks relating to the Encoding Guide for IENCs

No.	Check description	Check message	Check solution	Conformity to:	Cat.
1500a	For each achare, achbrt, CBLARE, FAIRWY, lokbsn, lkbspt and TWRTPT feature object which is WITHIN OR OVERLAPS a LNDARE feature object of geometric primitive area.	Achare, achbrt, CBLARE, FAIRWY, lokbsn, lkbspt and TWRTPT object overlaps a LNDARE object.	Amend objects to remove overlap.	Logical consistency	W
i2001	For each SBDARE feature object which is WITHIN, CROSSES OR OVERLAPS a LNDARE feature object of geometric primitive area.	SBDARE object is within or crosses a LNDARE object.	Amend objects to remove overlap.	Logical consistency	W
	<i>Check removed.</i>				
1502	For each spatial object where the attribute HORDAT is Present.	HORDAT used in a spatial object.	Remove HORDAT.	Logical consistency	E
1503	For each feature object (excluding m_vdat and m_sdat) where VERDAT/verdat is notNull AND all of the following attributes are Null: ELEVAT, HEIGHT, VERCCL, VERCLR, VERCOP, DRVAL1	Value of VERDAT/verdat without corresponding vertical distance value.	Remove VERDAT/verdat or populate vertical distance attribute.	G.1.1, G.1.2, G.1.3, G.1.4, G.1.5, G.1.6, G.1.8, G.1.9, G.1.11, G.1.12, G.1.13, G.3.3, G.3.4, G.3.7, G.3.20, G.4.5, G.4.8, G.4.9, I.3.4, I.3.5, M.1.3, M.1.4	E
1504	If the value of the VDAT subfield of the DSPM field is Null.	VDAT is not populated.	Populate the VDAT subfield with the vertical datum of the cell.	Logical consistency	C
1505	For each m_vdat meta object where verdat is notNull AND is Equal to the value of verdat in the VDAT subfield of the DSPM field.	Value of verdat is identical to the value of the VDAT subfield of the DSPM field.	Remove unnecessary value of verdat from m_vdat object.	C.1.5	E

No.	Check description	Check message	Check solution	Conformity to:	Cat.
1506	For each feature object where any of ELEVAT, HEIGHT, VERCCL, VERCLR, VERCOP is notNull AND which OVERLAPS OR CROSSES at least one m_vdat meta object.	Object with vertical distance value not split at boundary of m_vdat object.	Split object at boundary of m_vdat object or amend the m_vdat object to cover the entire feature object.	C.1.5	E
1507	For each m_vdat meta object which OVERLAPS OR is COVERED_BY another m_vdat meta object.	m_vdat objects overlap.	Edit m_vdat objects so that they do not overlap.	C.1.5	E
1508	For each m_sdat meta object which OVERLAPS OR is COVERED_BY another m_sdat meta object.	m_sdat objects overlap.	Edit m_sdat objects so that they do not overlap.	C.1.4	E
	<i>Check removed.</i>				
1510	If the SDAT subfield of the DSPM field is Null.	SDAT is not populated.	Populate the SDAT subfield with the sounding datum of the cell.	Logical consistency	C
1511	For each m_sdat meta object where verdat is Equal to the value of the SDAT subfield of the DSPM field.	m_sdat object has the same verdat as in the SDAT subfield of the DSPM.	Remove m_sdat object or amend value of VERDAT.	Logical consistency	E
1512a	For each SOUNDG feature object which CROSSES OR TOUCHES a m_sdat meta object.	SOUNDG object intersects boundary of a m_sdat object.	Split SOUNDG object at boundary of m_sdat object.	C.1.4, I.1.8	E
1512b	For each feature object where any of VALSOU, VALDCO, WATLEV, EXPSON, DRVAL1 or DRVAL2 is notNull AND which OVERLAPS OR COVERS OR CROSSES at least one m_sdat meta object.	Object with depth information intersects boundary of m_sdat objects.	Split object at boundary of m_sdat object.	C.1.4	E
1513	If the value of the HUNI subfield of the DSPM field is Not equal to 1 (metres).	HUNI subfield is not equal to 1 (metres).	Set value of HUNI to 1 (metres).	Annex 1 (6.3.2.3)	C
	<i>Check removed.</i>				

No.	Check description	Check message	Check solution	Conformity to:	Cat.
1515a	For each feature object where a value of DATEND, DATSTA, PEREND or PERSTA does not conform to the formatting defined in ISO 8601:1988.	Date attribute not formatted according to ISO 8601:1988.	Amend formatting to conform to ISO 8601:1988.	General Guidance J	C
1515b	For each feature object where a value of SORDAT, SUREND or SURSTA does not conform to the formatting defined in ISO 8601:1988.	Date attribute not formatted according to ISO 8601:1988.	Amend formatting to conform to ISO 8601:1988.	General Guidance J	E
1516	For each Group 2 feature object with allowable attributes STATUS, PEREND and PERSTA, where STATUS includes 5 (periodic/intermittent) AND PEREND or PERSTA are Null OR not Present.	PEREND or PERSTA not populated where STATUS = 5.	Populate PEREND or PERSTA with values or remove STATUS = 5 (periodic/intermittent).	General Guidance J	W
1517	<i>No TIMSTA and TIMEND in Annex 1, Appendix 1.</i>				
1518a	If the AGEN subfield of the DSID field is not one of the values listed in REF#IHO-S62 sections I and II or the REF#IHO-S100 registry.	Producing Agency code is not a valid REF#IHO-S62 or REF#IHO-S100 value.	Amend AGEN subfield to a valid REF#IHO-S62 or REF#IHO-S100 value.	Annex 1 (6.3.2.1)	C
1518b	If the first 2 characters of the data set file name do not correspond to the value of the AGEN subfield of the DSID field.	Data set file name does not begin with the agency code corresponding to that set in the AGEN subfield of the DSID field.	Amend the first 2 characters of the data set file name.	Annex 1 (5.6.3 and 6.3.2.1)	C
	<i>Check removed.</i>				
	<i>Check removed.</i>				
	<i>Check renumbered 1021a.</i>				
	<i>Check removed.</i>				
	<i>Check removed.</i>				
1522b	If the file extension is not ".000" AND the UADT subfield of the DSID field is notNull.	UADT is notNull for an update.	Encode UADT as missing subfield value.	Annex 1 (5.7 and 6.1.4)	C
	<i>Check removed.</i>				

No.	Check description	Check message	Check solution	Conformity to:	Cat.
1523b	If the data set file name extension is Equal to ".000" AND the ISDT subfield of the DSID field is Less than the value of the UADT subfield.	The ISDT of a base cell file precedes the UADT.	Amend UADT or ISDT accordingly.	Annex 1 (5.7)	C
1524	No SWPARE in Annex 1, Appendix 1.				
1525	For each M_QUAL meta object where POSACC is notNull AND DRVAL1 is notNull.	M_QUAL object with both DRVAL1 and POSACC populated.	Remove POSACC from M_QUAL object.	C.1.2 and C.1.6	E
	<i>Check removed.</i>				
	<i>Check removed.</i>				
	<i>Check removed.</i>				
1529	For each feature object COVERED_BY a M_QUAL meta object where TECSOU is notNull AND the value of TECSOU is Equal to the TECSOU of the M_QUAL meta object.	TECSOU value of a feature object is equal to value for the M_QUAL object it lies within.	Remove unnecessary value of TECSOU from feature object.	C.1.2, C.1.6, C.1.7, C.1.8, J.2.1 and Annex 1 (3.5.6)	E
1530	For each feature object COVERED_BY a M_QUAL meta object where SOUACC is notNull AND the value of SOUACC is Equal to the SOUACC OR is equivalent to the CATZOC values of the M_QUAL meta object.	SOUACC value of a feature object is equal to the SOUACC value or equivalent to the value of CATZOC of the M_QUAL object it lies within.	Remove unnecessary value of SOUACC from feature object.	C.1.2, C.1.6, C.1.9, I.1.8, M.1.3, M.1.4, M.4.7, and Annex 1 (3.5.6)	E
1531	For each M_QUAL meta object where the value of POSACC, SOUACC or TECSOU is notNull AND is equivalent to or degrades the accuracy indicated by the value of CATZOC.	Value of POSACC, SOUACC, or TECSOU is equivalent to or degrades the accuracy indicated by the value of CATZOC.	Amend CATZOC value or remove inappropriate value of POSACC, SOUACC or TECSOU from M_QUAL object.	C.1.2, C.1.6 and Annex 1 (3.5.6)	E

No.	Check description	Check message	Check solution	Conformity to:	Cat.
1532	For each M_QUAL meta object where SURSTA is Not equal to the smallest (oldest) value of SURSTA of the M_SREL meta objects it COVERS.	SURSTA of a M_QUAL object is not equal to the oldest survey within the M_QUAL object.	Amend the SURSTA value of M_QUAL object to reflect the oldest survey within it.	C.1.2 and C.1.6	E
1533	<i>No SOUACC for DRGARE in Annex 1, Appendix 1.</i>				
1534	<i>No SOUACC for UMTROC/uwtroc in Annex 1, Appendix 1.</i>				
1535	<i>No SOUACC for UMTROC/uwtroc in Annex 1, Appendix 1.</i>				
1536	<i>No SOUACC for WRECKS in Annex 1, Appendix 1.</i>				
1537	<i>No SOUACC for WRECKS in Annex 1, Appendix 1.</i>				
1538	<i>No SOUACC for OBSTRN in Annex 1, Appendix 1.</i>				
1539	<i>No SOUACC for OBSTRN in Annex 1, Appendix 1.</i>				
	<i>Check removed.</i>				
1541	<i>No QUASOU for SOUNDG in Annex 1, Appendix 1.</i>				
1542	<i>No spatial objects with POSACC in Annex 1, Appendix 1.</i>				
	<i>Check removed.</i>				
1544	<i>HORACC, SOUACC and VERACC are allowed for M_ACCY in Annex 1, Appendix 1.</i>				

No.	Check description	Check message	Check solution	Conformity to:	Cat.
1545	For each bridge, tunnel, dry dock, floating dock, lock gate object where HORACC is notNull AND HORCLR is Null OR not Present.	Value for HORACC without a value of HORCLR. <i>HORACC is allowed for many features without HORCLR. It is therefore possible to encode HORACC also for the listed features without HORCLR, but there should be a warning</i>	Add HORCLR value.	G.1.1, G.1.2, G.1.3, G.1.4, G.1.5, G.1.6, G.1.7, G.1.11, G.1.12, G.1.13, G.3.6, G.3.7, G.4.5	W
1546	For each bridge, tunnel, overhead cable, overhead pipe, conveyor, crane, lock gate object where VERACC is notNull AND VERCLR, VERCOP, VERCOSA and VERCCL are Null OR not Present.	Value for VERACC without value of VERCLR, VERCOP, VERCOSA or VERCCL. <i>VERACC is allowed for many features without vertical clearance values. It is therefore possible to encode VERACC also for the listed features without vertical clearance values, but there should be a warning</i>	Populate vertical clearance value.	G.1.1, G.1.2, G.1.3, G.1.4, G.1.5, G.1.6, G.1.7, G.1.8, G.1.9, G.1.11, G.1.12, G.1.13, G.3.3, G.3.4, G.4.5	W
	<i>Check removed.</i>				
1548	For each feature object where SORIND is notNull AND SORDAT is Null OR not Present.	Value of SORIND without a value of SORDAT.	Populate SORDAT with an appropriate value.	B B	W
1549	If the value of CSCL subfield of the DSPM field is Null.	CSCL is not populated with a value.	Populate CSCL with an appropriate value.	Annex 1 (6.3.2.3)	C
1550	<i>No M_CSCL in Annex 1, Appendix 1.</i>				

No.	Check description	Check message	Check solution	Conformity to:	Cat.
1551	<i>No M_CSCL in Annex 1, Appendix 1.</i>				
	<i>Check removed.</i>				
1553	For each value of SCAMIN which is Less than OR Equal to the compilation scale of the data for the area.	SCAMIN value less than or equal to compilation scale.	Amend SCAMIN value.	Logical consistency	E
1554a	For each Group 1 feature object where SCAMIN is Present.	SCAMIN present for a Group 1 object.	Remove SCAMIN.	Logical consistency	C
1554b	For each meta object where SCAMIN is Present.	SCAMIN present for a meta object.	Remove SCAMIN.	C.1	C
	<i>Check removed.</i>				
	<i>Check renumbered 1022.</i>				
1557	<i>no T_HMON in Annex 1, Appendix 1.</i>				
1558	<i>no T_NHMN in Annex 1, Appendix 1.</i>				
1559	<i>no T_NHMN in Annex 1, Appendix 1.</i>				
1560	<i>no TS_PRH in Annex 1, Appendix 1.</i>				
1561	<i>no TS_PNH in Annex 1, Appendix 1.</i>				
1562	<i>no TS_PNH in Annex 1, Appendix 1.</i>				
1563	For each RIVERS, CANALS, LAKARE, feature object which is not COVERED_BY a LNDARE or UNSARE feature object of geometric primitive area.	Non navigable water objects not covered by UNSARE or LNDARE object.	Amend LNDARE or UNSARE to cover non navigable water objects.	D.1.1, D.1.2, D.1.5	W
1564	<i>No CTRPNT in Annex 1, Appendix 1.</i>				

No.	Check description	Check message	Check solution	Conformity to:	Cat.
1565	<p>For each edge of a LNDARE feature object of geometric primitive area which is not COINCIDENT with one of the following feature objects:</p> <p>a) COALNE, SLCONS, slcons, GATCON, gatcon or DAMCON of geometric primitive line.</p> <p>OR</p> <p>b) M_COVR, GATCON, gatcon, DAMCON, RIVERS, TUNNEL, DRYDOC, CANALS, LAKARE, lokbsn, lkbspt_DOCARE or LNDARE of geometric primitive area.</p> <p>OR</p> <p>c) CAUSWY, SLCONS, slcons, MORFAC, WRECKS, OBSTRN or PYLONS where WATLEV is Equal to 1 (partly submerged at high water) OR 2 (always dry) OR 6 (subject to inundation or flooding).</p>	LNDARE object not enclosed by appropriate linear or area object.	Ensure LNDARE is enclosed by an appropriate object.	Logical consistency, Annex 1, Appendix 2	E
1566	<p>For each edge of a COALNE or SLCONS or slcons_feature object of geometric primitive line which is COINCIDENT with a RIVERS, CANALS, LAKARE, DOCARE, DRYDOC or lokbsn, feature object AND is not COINCIDENT with a DEPARE, depare, DRGARE, UNSARE, PONTON, ponton, FLODOC, flodoc or HULKES or hulkes feature object.</p>	COALNE or SLCONS or slcons object used as the boundary of objects on land.	Remove COALNE or SLCONS or slcons object.	Logical consistency, Annex 1, Appendix 2	E
1567	<i>VERACC is allowed for COALNE in IENCs.</i>				
1568	<p>For each SLCONS and slcons feature object of geometric primitive area which is not COVERED_BY the combined coverage of LNDARE, DEPARE, depare or UNSARE feature objects of geometric primitive area.</p>	Area SLCONS or slcons object not covered by an appropriate Group 1 object.	Amend appropriate Group 1 object to cover SLCONS or slcons object.	G.2	E

No.	Check description	Check message	Check solution	Conformity to:	Cat.
1569	For each SLCONS feature object of geometric primitive area where WATLEV is Equal to 3 (always under water/submerged) OR 4 (covers and uncovers) OR 5 (awash) AND which is not COVERED_BY a DEPARE, depare and/or UNSARE feature object of geometric primitive area.	Area SLCONS object not covered by an appropriate Group 1 object.	Amend appropriate Group 1 object to cover SLCONS object.	G.2	E
i1501	For each slcons feature object of geometric primitive area where watlev is Equal to 3 (always under water/submerged) OR 4 (covers and uncovers) OR 9 (below mean water level) AND which is not COVERED_BY a DEPARE, depare and/or UNSARE feature object of geometric primitive area.	Area slcons object not covered by an appropriate Group 1 object.	Amend appropriate Group 1 object to cover slcons object.	G.2	E
1570	<i>Allowed for IENCs</i>				
1571	<i>verdat allowed for berths in IENCs</i>				
1572	<i>No VERDAT for DRYDOC in Annex 1, Appendix 1</i>				
1573	For each DRYDOC feature object which is not COVERED_BY a LNDARE feature object of geometric primitive area.	DRYDOC object not covered by a LNDARE object.	Amend LNDARE object or DRYDOC object as required.	G.3.6	E
	<i>Check removed.</i>				
1575	<i>Allowed in IENCs</i>				
i1502	For each flodoc feature that has an attribute value for verdat Equal to that given in the Vertical Datum subfield (VDAT) of the Data Set Parameter field (DSPM) or in the verdat attribute of the Meta object m_vdat.	verdat populated with equal value as VDAT or verdat of m_vdat	Remove value of verdat in flodoc	G.3.7	E
	<i>Check removed.</i>				
1577	<i>No DOCARE in Annex 1, Appendix 1</i>				

No.	Check description	Check message	Check solution	Conformity to:	Cat.
1578	For each GATCON and gatcon feature object where VERDAT/verdat is notNull AND VERCLR is not Present.	VERDAT/verdat populated without VERCLR being present for a GATCON or gatcon object.	Remove VERDAT/verdat or populate VERCLR for GATCON/gatcon object.	G.4.5, G.4.9	E
	<i>Check removed.</i>				
1580	For each GATCON feature object which is not COVERED_BY the combined coverage of DEPARE, depare, DRGARE or UNSARE feature objects of geometric primitive area.	GATCON object not covered by a DEPARE, depare, DRGARE or UNSARE object.	Amend objects to ensure GATCON is covered by DEPARE, depare, DRGARE or UNSARE	G.4.5	E
i1503	For each gatcon feature of geometric primitive area which is not COVERED_BY a DEPARE, depare, DRGARE or UNSARE object of geometric primitive Area.	gatcon object not covered by a DEPARE, depare, DRGARE or UNSARE object.	Amend objects to ensure gatcon is covered by DEPARE, depare, DRGARE, UNSARE.	G.4.5	W for EU
i1504	For each gatcon feature, that has an attribute value for verdat Equal to that given in the Vertical Datum subfield (VDAT) of the Data Set Parameter field (DSPM) or in the verdat attribute of the Meta object m_vdat.	verdat populated with equal value as VDAT or verdat of m_vdat	Remove value of verdat in gatcon	G.4.5	E for EU
1581	<i>Check Removed for IENC.</i>				
i1505	For each lokbsn_feature which is not COVERED_BY a DEPARE or a depare feature.	lokbsn feature not covered by a DEPARE or depare feature	Amend objects to ensure lokbsn_is covered by DEPARE or depare	G.4.3	E
i1506	For all features which belong to one lock (lokbsn or lkbspt) not combined to one aggregation area (C_AGGR).	Features of a lock not combined to one C_AGGR	Amend C_AGGR to include all features of the lock	G.4.3, G.4.4	E
i1516	For each lkbspt feature not COVERED_BY a DEPARE or depare feature of geometric primitive area.	lkbspt without DEPARE or depare	Amend DEPARE or depare	G.4.4	E

No.	Check description	Check message	Check solution	Conformity to:	Cat.
1582	<i>No HORACC and VERACC for GRIDRN in Annex 1, Appendix 1.</i>				
1583	<i>Allowed for IENCs.</i>				
1584	For each MORFAC feature object of geometric primitive area where WATLEV is Equal to 2 (always dry) which is not COVERED_BY a LNDARE feature object of geometric primitive area.	Area MORFAC object with WATLEV = 2 not covered by a LNDARE object.	Amend MORFAC object or LNDARE object as required.	G.3.12	E
i1508	For each MORFAC feature COVERED_BY more than one SEAARE feature.	MORFAC object covered by more than one SEAARE.	Remove one SEAARE	G.3.13	E
1585	<i>Allowed for IENCs.</i>				
1586	<i>Allowed for IENCs.</i>				
i1509	For each ponton feature not OVERLAPS a DEPARE or depare feature.	ponton object not overlaps DEPARE or depare.	Amend DEPARE or depare to overlap ponton.	G.3.11	W
1587	<i>Allowed for IENCs.</i>				
i1510	For each hulkes feature not COVERED_BY by a DEPARE or depare feature.	hulkes object not covered by DEPARE or depare.	Amend DEPARE or depare to cover hulkes.	G.3.14	W
	<i>Check removed.</i>				
1589	<i>n.a. for IENCs.</i>				
1590	For each LNDRGN feature object that is DISJOINT from a LNDARE feature object.	LNDRGN not covered by LNDARE object.	Ensure LNDRGN object is covered by or contains a LNDARE object.	B.E, D.2.2	W
1591	<i>No LNDELV in Annex 1, Appendix 1.</i>				
1592	For each COALNE feature object which is COINCIDENT with a LNDRGN feature object where CATLND is Equal to 2 (marsh) AND CATCOA for the COALNE feature object is Not equal to 8 (marshy shore).	Invalid value of QUAPOS or CATCOA for a COALNE object adjacent to a LNDRGN where CATLND = 2.	Amend value of CATCOA or QUAPOS as required for COALNE object.	Logical consistency	W

No.	Check description	Check message	Check solution	Conformity to:	Cat.
1593	<i>No NATCON and NATQUA for SLOGRD in Annex 1, Appendix 1.</i>				
1594	<i>No NATCON and NATQUA for SLOTOP in Annex 1, Appendix 1.</i>				
1595	For each SLOTOP feature object where CATSLO is Equal to 6 (cliff) AND is COINCIDENT with a COALNE object.	SLOTOP object where CATSLO = 6 coincides with a COALNE object.	Remove SLOTOP object. Only COALNE with CATCOA = 1 (steep coast) should be encoded.	Logical consistency	W
	<i>Check removed.</i>				
1597	For each RIVERS feature object which EQUALS a SEAARE feature object.	RIVERS object equals a SEAARE object.	Amend SEAARE object.	D.1.1, D.1.2	E
1598	<i>No RAPIDS in Annex 1, Appendix 1.</i>				
1599a	<i>No RAPIDS in Annex 1, Appendix 1.</i>				
1599b	<i>No RAPIDS in Annex 1, Appendix 1.</i>				
1600	<i>No WATFAL in Annex 1, Appendix 1.</i>				
1601	<i>No VERACC and VERDAT for LAKARE in Annex 1, Appendix 1.</i>				
1602	For each LAKARE feature object which EQUALS a SEAARE feature object.	LAKARE object equals SEAARE object.	Amend objects to remove overlap.	D.1.5	W
	<i>Check removed.</i>				
1604	<i>No CATLND 15 in Annex 1, Appendix 1.</i>				
1605	<i>No ICEARE in Annex 1, Appendix 1.</i>				
1606	<i>No ICEARE in Annex 1, Appendix 1.</i>				
1607a	<i>No CATVEG 7 in Annex 1, Appendix 1.</i>				
1607b	<i>No CATVEG 7 in Annex 1, Appendix 1.</i>				
1608	<i>No VERACC and VERDAT for VEGATN in Annex 1, Appendix 1.</i>				

No.	Check description	Check message	Check solution	Conformity to:	Cat.
1609	For each CANALS feature object which EQUALS a SEAARE object.	CANALS object equals SEAARE object.	Remove SEAARE object or amend objects to remove overlap.	D.1.1, D.1.3	W
1610	<i>No VERACC for RAILWY in Annex 1, Appendix 1.</i>				
1611	<i>Allowed for IENCs.</i>				
	<i>Check removed.</i>				
1613	<i>Allowed for IENCs.</i>				
1614	For each TUNNEL feature object which COVERS any non-hydrographic object (for this check hydrographic objects are DEPARE, DEPCNT, DRGARE and LNDARE).	TUNNEL object contains non Hydrographic object.	Remove objects within TUNNEL object which are unnecessary.	G.1.7	W
	<i>Check removed.</i>				
1616	<i>Allowed for IENCs.</i>				
1617	For each DAMCON feature object of geometric primitive area which is not COVERED_BY a LNDARE feature object of geometric primitive area.	DAMCON not covered by LNDARE.	Ensure DAMCON object is covered by a LNDARE object.	G.4.2	C
1618	<i>Allowed for IENCs.</i>				
1619	For each DYKCON feature object of geometric primitive area which is not WITHIN a LNDARE feature object of geometric primitive area.	DYKCON area object not covered by LNDARE object.	Ensure DYKCON object is covered by a LNDARE object.	G.2.1	E
1620	For each edge of a DYKCON feature object which is COINCIDENT with both a LNDARE feature object AND a DEPARE, depare or DRGARE or UNSARE feature object of geometric primitive area AND is not COINCIDENT with a SLCONS or slcons feature object of geometric primitive line where CATSLC is not Present.	DYKCON object not enclosed by SLCONS or slcons object where it forms the boundary between water and land.	Add SLCONS_ or slcons object to ensure boundary between land and water is shown.	G.2.1	E
	<i>Check removed.</i>				
	<i>Check removed.</i>				

No.	Check description	Check message	Check solution	Conformity to:	Cat.
1623	For each bridge feature object which OVERLAPS OR CROSSES a DEPARE, depare or DRGARE feature object AND the supports are not encoded with PYLONS feature objects where CATPYL is Equal to 4 (bridge pylon/tower) OR 5 (bridge pier).	bridge object over navigable water with supports not encoded using a valid PYLONS object/attribute combination.	Ensure bridge supports are encoded using PYLONS objects with CATPYL = 4 (bridge pylon/tower) or 5 (bridge pier).	G.1.10	E
i1511	For all features which belong to one bridge (pylons, lights, notice marks, sistat) not combined to one aggregation area (C_AGGR).	Features of a bridge not combined to one C_AGGR	Amend C_AGGR to include all features of the bridge	G.1, N.1.1, O.1.2, O.3.2, R.2.1	W
i1512	For each bridge feature, that has an attribute value for verdat Equal to that given in the Vertical Datum subfield (VDAT) of the Data Set Parameter field (DSPM) or in the verdat attribute of the Meta object m_vdat.	verdat populated with equal value as VDAT or verdat of m_vdat	Remove value of verdat in bridge	G.1	E
i1557	For each notmrk feature that is a bridge notmrk (catnmk=12,13,44,45,46,47 or 50) where ORIENT is not Present. If the notmrk with attribute catnmk = 50 (value name E.1) is not positioned at a bridge, then ORIENT is not required.	bridge notice mark without ORIENT value	Amend ORIENT	O.3.2	E
	<i>Check removed.</i>				
1625	For each AIRARE or RUNWAY feature object associated using a C_AGGR collection object.	AIRARE object or RUNWAY object associated using C_AGGR.	Encode association using C_ASSO not C_AGGR.	E.2.1	W
1626	<i>No CONVIS for AIRARE in Annex 1, Appendix 1.</i>				
1627	<i>Allowed for IENCs.</i>				
1628	<i>No VERACC and VERDAT for PRDARE in Annex 1, Appendix 1.</i>				
1629	<i>No VERACC and VERDAT for BUAARE in Annex 1, Appendix 1.</i>				
1630	<i>Allowed for IENCs.</i>				

No.	Check description	Check message	Check solution	Conformity to:	Cat.
1631	No VERACC and VERDAT for BUISGL in Annex 1, Appendix 1.				
1632	No VERACC and VERDAT for SILTNK in Annex 1, Appendix 1.				
1633	No VERACC and VERDAT for LNDMRK in Annex 1, Appendix 1.				
1634	No VERACC and VERDAT for FNCLNE in Annex 1, Appendix 1.				
1635	No VERACC and VERDAT for FORSTC in Annex 1, Appendix 1.				
1636	Allowed for IENCs.				
1637	For each PYLONS feature object of geometric primitive area where WATLEV is Equal to 1 (partly submerged at high water) OR 2 (always dry) which is not COVERED_BY a LNDARE feature object of geometric primitive area.	Area PYLONS object with WATLEV = 1, 2 or 6 not covered by a LNDARE object.	Ensure area PYLONS object is covered by a LNDARE object.	G.1.10	E
	Check renumbered 1023.				
1639	No VERDAT for DEPCNT in Annex 1, Appendix 1.				
1640	No VERDAT for SOUNDG in Annex 1, Appendix 1.				
1641	For each UWTRC and uwtrc feature object which INTERSECTS a SOUNDG feature object (horizontal component only).	UWTRC or uwtrc shares position with SOUNDG object.	Remove object that is not required.	J.1.1	E
1642	No VERDAT and SOUACC for DEPARE in Annex 1, Appendix 1.				
	Check removed.				
1644	n.a for IENCs.				
	Check removed.				
1646	No DRVAL2 for DRGARE in Annex 1, Appendix 1.				
1647	No VERDAT for DRGARE in Annex 1, Appendix 1.				
	Check removed.				

No.	Check description	Check message	Check solution	Conformity to:	Cat.
1649	<i>No SOUACC for DRGARE in Annex 1, Appendix 1.</i>				
1650	<i>No SWPARE in IENCs.</i>				
1651	<i>No SWPARE in IENCs.</i>				
1652	<i>No SWPARE in IENCs.</i>				
1653	<i>No SWPARE in IENCs.</i>				
1654	<i>No SWPARE in IENCs.</i>				
1655	<i>No SWPARE in IENCs.</i>				
1656	<i>No VERDAT for UWTROC in Annex 1, Appendix 1.</i>				
1657	<i>Check removed for IENC.</i>				
1658	<i>Allowed in IENCs.</i>				
1659a	For each WRECKS feature object where VALSOU is notNull AND EXPSOU is Equal to 1 (within the range of depth of the surrounding depth area) OR is not Present AND VALSOU is Less than or equal to the DRVAL1 OR Greater than DRVAL2 of the DEPARE or depare feature object it OVERLAPS OR is COVERED_BY.	VALSOU for WRECKS object with EXPSOU = 1 or not present is outside of the range of the underlying DEPARE object.	Populate an appropriate value of EXPSOU for the WRECKS object.	J.2.1	E
1659b	For each WRECKS feature object where VALSOU is notNull AND EXPSOU is Equal to 1 (within the range of depth of the surrounding depth area) OR is not Present AND VALSOU is Less than or equal to the DRVAL1 OR Greater than DRVAL2 of the DRGARE feature object it OVERLAPS OR is COVERED_BY AND DRVAL2 is notNull AND Not equal to DRVAL1.	VALSOU for WRECKS object with EXPSOU = 1 or not present is outside of the range of the underlying DRGARE object.	Populate an appropriate value of EXPSOU for the WRECKS object.	J.2.1	E

No.	Check description	Check message	Check solution	Conformity to:	Cat.
1660	For each WRECKS feature object where VALSOU is notNull AND EXPSOU is Equal to 2 (shoaler than the range of depth of the surrounding depth area) AND VALSOU is Greater than the DRVAL1 of the DEPARE, depare or DRGARE feature object it OVERLAPS OR is COVERED_BY AND DRVAL1 is notNull.	WRECKS object where EXPSOU = 2 and VALSOU is greater than the DRVAL1 of the underlying DEPARE/ depare/ DRGARE object.	Populate an appropriate value of EXPSOU for the WRECKS object.	J.2.1	E
1661a	For each WRECKS feature object where VALSOU is notNull AND EXPSOU is Equal to 3 (deeper than the range of depth of the surrounding depth area) AND VALSOU is Less than or equal to DRVAL2 of the DEPARE or depare feature object it OVERLAPS OR is COVERED_BY AND DRVAL2 is notNull.	WRECKS object where EXPSOU = 3 and VALSOU is less than DRVAL2 of the underlying DEPARE or depare object.	Populate an appropriate value of EXPSOU for the WRECKS object.	J.2.1	E
	<i>DRGARE does not have DRVAL2 in the Annex 1, Appendix 1.</i>				
1661c	For each WRECKS feature object where EXPSOU is Equal to 3 (deeper than the range of depth of the surrounding depth area) AND VALSOU is Less than or equal to the DRVAL1 of the DRGARE feature object it OVERLAPS OR is COVERED_BY.	WRECKS object where EXPSOU= 3 and VALSOU is less than DRVAL1 of the underlying DRGARE object.	Populate an appropriate value of EXPSOU for the WRECKS object.		E
	<i>Check removed.</i>				
i1548	For each WRECKS feature where CATWRK is not Present and attribute SCAMIN is Not 22000 (EU) or 45000 (US).	Mandatory attributes CATWRK and SCAMIN of WRECKS object not present.	Populate CATWRK and SCAMIN with correct values	J.2.1	E
i1549	For each WRECKS feature where WATLEV is Equal to 3 (always under water/submerged) and VALSOU is not Present.	Missing VALSOU	Populate VALSOU	J.2.1	E
i1515	For each hrbsn feature that OVERLAPS a LNDARE feature of geometric primitive area.	hrbsn object on LNDARE	Amend limits of LNDARE	G.3.10	E

No.	Check description	Check message	Check solution	Conformity to:	Cat.
i1523	For each wtwprf feature that has an attribute value for verdat Equal to that given in the Vertical Datum subfield (VDAT) of the Data Set Parameter field (DSPM) or in the verdat attribute of the Meta object m_vdat.	verdat populated with equal value as VDAT or verdat of m_vdat	Remove value of verdat in wtwprf	I.3.5	E
i1524	For each wtwprf feature that has an attribute value for HEIGHT without an attribute value for reflev.	HEIGHT without reflev	Populate reflev	I.3.5	E
i1537	For each boylat feature that has an attribute value for marsys equal to that given in the marsys attribute of the Meta object m_nsys.	marsys populated with equal value as marsys of m_nsys	Remove value of marsys in boylat	O.1.2	E
i1545	For each tisdge feature Not associated (using the collection object C_ASSO) with the other features of the facility.	tisgde not associated	Create C_ASSO for all features of the facility	T.1.1	W
1664	<i>Allowed for IENCs.</i>				
1665a	For each OBSTRN feature object where VALSOU is notNull AND EXPSOU is Equal to 1 (within the range of depth of the surrounding depth area) OR not Present AND VALSOU is Less than or equal to DRVAL1 OR Greater than DRVAL2 of the DEPARE or depare feature object it OVERLAPS, CROSSES OR is COVERED_BY.	VALSOU for OBSTRN object with EXPSOU = 1 or not present is outside of the range of the underlying DEPARE or depare object.	Populate an appropriate value of EXPSOU for the OBSTRN object.	J.3.1	E
1665b	For each OBSTRN feature object where VALSOU is notNull AND EXPSOU is Equal to 1 (within the range of depth of the surrounding depth area) OR not Present AND VALSOU is Less than or equal to DRVAL1 of the DRGARE feature object it OVERLAPS, CROSSES OR is COVERED_BY.	VALSOU for OBSTRN object with EXPSOU = 1 or not present is outside of the range of the underlying DRGARE object.	Populate an appropriate value of EXPSOU for the OBSTRN object.	J.3.1	E

No.	Check description	Check message	Check solution	Conformity to:	Cat.
1666	For each OBSTRN feature object where VALSOU is notNull AND EXPSOU is Equal to 2 (shoaler than the range of depth of the surrounding depth area) AND VALSOU is Greater than the DRVAL1 of the DEPARE, depare or DRGARE feature object it OVERLAPS, CROSSES OR is COVERED_BY AND DRVAL1 is notNull.	OBSTRN object where EXPSOU = 2 and VALSOU is greater than DRVAL1 of the underlying DEPARE/ depare/ DRGARE object.	Populate an appropriate value of EXPSOU for the OBSTRN object.	J.3.1	E
1667a	For each OBSTRN feature object where VALSOU is notNull AND EXPSOU is Equal to 3 (deeper than the range of depth of the surrounding depth area) AND VALSOU is Less than or equal to DRVAL2 of the DEPARE or depare feature object it OVERLAPS, CROSSES OR is COVERED_BY AND DRVAL2 is notNull.	OBSTRN object where EXPSOU = 3 and VALSOU is less than DRVAL2 of the underlying DEPARE or depare object.	Populate an appropriate value of EXPSOU for the OBSTRN object.	J.3.1	E
1667b	<i>No DRVAL2 for DRGARE in Annex 1, Appendix 1.</i>				
1667c	For each OBSTRN feature object where EXPSOU is Equal to 3 (deeper than the range of depth of the surrounding depth area) AND VALSOU is Less than or equal to the DRVAL1 of the DRGARE feature object it OVERLAPS, CROSSES OR is COVERED_BY.	OBSTRN object where EXPSOU = 3 and VALSOU is less than DRVAL1 of the underlying DRGARE object.	Populate an appropriate value of EXPSOU for the OBSTRN object.	J.3.1	E
1668	<i>No PRODCT for OBSTRN in Annex 1, Appendix 1.</i>				
1669	For each OBSTRN feature object where the attribute values do not correspond to the table below.	OBSTRN object with illogical attribute value combinations.	Amend attributes in accordance with the logical values defined in the table.	J.3.1	E
	VALSOU	WATLEV	QUASOU		
	Unknown	3, 4, 5 OR Null	2 OR not Present		
1 OR 2		not Present			

No.	Check description		Check message	Check solution	Conformity to:	Cat.
	< 0	4	6, 8 OR not Present			
		4	7			
	0	5	6, 8 OR not Present			
	> 0	3	6, 8 OR not Present			
		3	7			
1670	For each WRECKS or OBSTRN feature object of geometric primitive area which COVERS a WRECKS or OBSTRN feature object of geometric primitive point AND the values of EXPSOU, QUASOU, VALSOU and WATLEV of the area feature object are Not equal to the values of the shallowest point feature object.		Point WRECKS or OBSTRN object within area WRECKS or OBSTRN object have attribute values not reflected for the area object.	Ensure area WRECKS or OBSTRN object attribute values reflect the values of the shallowest point object.	J.2.1, J.3.1	W
1671	For each feature object of geometric primitive line which is COINCIDENT with an area feature object of the same feature object class AND has the same attribute values (excluding attributes SORIND, SORDAT and SCAMIN).		Line object touching area object of the same class with the same attribute values except SORIND, SORDAT and SCAMIN.	Remove unnecessary object.	Logical consistency	W
1672	For each feature object of geometric primitive point which is COVERED_BY an area feature object of the same class AND has the same attribute values AND is not a LNDARE, OBSTRN or WRECKS feature object.		Point object within an area object of the same class with the same attribute values.	Remove duplicate object or amend attributes accordingly.	Logical consistency	E
1673a	For each SBDARE feature object where NATSUR values are not separated by a comma or slash (without spaces).		NATSUR values not separated by a comma or slash.	Insert comma or slash for NATSUR value as required.	J.4.1	E
1673b	For each SBDARE feature object where NATSUR starts or ends with a comma or slash.		NATSUR starts or ends with a comma or slash.	Remove unnecessary comma or slash from NATSUR value.	J.4.1	W

No.	Check description	Check message	Check solution	Conformity to:	Cat.
1673c	For each SBDARE feature object where NATSUR contains ',', OR '/'.	Consecutive comma or slash within NATSUR.	Remove unnecessary comma or slash from NATSUR value.	J.4.1	W
1673d	For each SBDARE feature object where NATSUR contains commas or slashes AND the total of these does Not equal number of commas and slashes contained in NATQUA.	The number of commas and slashes in NATSUR is different from the number of commas and slashes in NATQUA.	Ensure appropriate commas or slashes are used to separate values.	J.4.1	W
1673e	For each SBDARE feature object where NATSUR contains '9/ '.	NATSUR contains '9/ ' (Rock is encoded as the surface layer, it should be underlying).	Remove or amend inappropriate NATSUR contents.	J.4.1	W
	<i>No WATLEV for BDARE in Annex 1, Appendix 1.</i>				
1675	<i>No VERACC for SNDWAV in Annex 1, Appendix 1.</i>				
	<i>Check removed.</i>				
1677	For each MORFAC feature object where BOYSHP is Present AND CATMOR is Not equal to 7 (mooring buoy).	MORFAC object with BOYSHP without CATMOR = 7.	Set value of CATMOR to 7(mooring buoy) or remove BOYSHP for MORFAC.	G.3.12	E
1678	<i>Allowed for IENCs.</i>				
1679	For each feature object where attributes of types enumerated ('E'), float ('F'), integer ('I') or code string ('A') have more than one value.	More than one value present for attributes of the following types; enumerated ('E'), float ('F'), integer ('I') or code string ('A').	Remove unnecessary attribute values.		C
	<i>Check removed.</i>				
1681	For each RECTRC feature object of geometric primitive line where ORIENT is notNull AND TRAFIC is Equal to 1 (inbound) OR 2 (outbound) OR 3 (one-way) AND the bearing of the line is more than 5 degrees Greater than OR Less than the value of ORIENT.	RECTRC where ORIENT does not correspond to the bearing of the line.	Populate an appropriate value of ORIENT consistent with the geometry of the RECTRC object.	L.1.2	C

No.	Check description	Check message	Check solution	Conformity to:	Cat.
1682	<i>Not required in Annex 1, Appendix 2.</i>				
1683	<i>Not required in Annex 1, Appendix 2.</i>				
1684	<i>Not required in Annex 1, Appendix 2.</i>				
1685a	<i>Not required in Annex 1, Appendix 2.</i>				
1685b	<i>Not required in Annex 1, Appendix 2.</i>				
1686	<i>Not required in Annex 1, Appendix 2.</i>				
1687	<i>Not required in Annex 1, Appendix 2.</i>				
1688	<i>Not required in Annex 1, Appendix 2.</i>				
1689	<i>Not required in Annex 1, Appendix 2.</i>				
1690	<i>Not required in Annex 1, Appendix 2.</i>				
1691	<i>No DWRTPT in IENCs.</i>				
1692	<i>No DWRTPT in IENCs.</i>				
1693	<i>No DWRTPT in IENCs.</i>				
1694	<i>No DWRTCL in IENCs.</i>				
1695	<i>No DWRTCL in IENCs.</i>				
1696	<i>No RCRTCL in IENCs.</i>				
1697	<i>No RCRTCL in IENCs.</i>				
1698	<i>No DRVAL2 and VERDAT for TWRTPT in Annex 1, Appendix 1.</i>				
1699	<i>No VERDAT for FAIRWY in Annex 1, Appendix 1.</i>				
1700	<i>No TESARE in IENCs.</i>				
1701	<i>No VERDAT for CBLSUB in Annex 1, Appendix 1.</i>				
1702	<i>No STATUS 4 for CBLSUB in Annex 1, Appendix 1.</i>				
1703	<i>Allowed for IENCs.</i>				

No.	Check description	Check message	Check solution	Conformity to:	Cat.
1704	For each cblohd feature object where VERCLR is not Present.	cblohd object without value of VERCLR	Populate VERCLR for cblohd object.	G.1.8	E
	<i>Check removed.</i>				
	<i>Covered by i2000.</i>				
1707	<i>Allowed for IENCs.</i>				
1708	<i>No VERACC and VERDAT for PIPSOL in Annex 1, Appendix 1.</i>				
1709	<i>No STATUS 4 for PIPSOL in Annex 1, Appendix 1.</i>				
	<i>Check removed.</i>				
	<i>Check removed.</i>				
1712	<i>No STATUS for pipohd in Annex 1, Appendix 1.</i>				
1713	<i>Allowed for IENCs.</i>				
	<i>Check removed.</i>				
1715	<i>No VERACC and VERDAT for OFSPLF in Annex 1, Appendix 1.</i>				
1716	<i>No VERACC for OSPARE in Annex 1, Appendix 1.</i>				
1717	<i>No VERACC for FSHFAC in Annex 1, Appendix 1.</i>				
1718	<i>No VERDAT for MARCUL in Annex 1, Appendix 1</i>				
1719	For each MARCUL feature object where the attribute values do not correspond to the table below. [For each specific case, when QUASOU is encoded, it should contain one or more values selected from the list of allowed values given in the table.]	Illogical attribute combination for MARCUL.	Amend attributes in accordance with the logical values defined in the table.	M.4.7	W
	WATLEV	VALSOU	QUASOU		
	1, 2, 5 OR 7	not Present	not Present		
	4	< 0	1, 3, 4, 6, 7, 8, 9 OR not Present		
		not Present OR Null	2 OR not Present		
	5	0	1, 3, 4, 6, 8, 9 OR not Present		
		not Present OR Null	2 OR not Present		

No.	Check description	Check message	Check solution	Conformity to:	Cat.
	3	> 0	1, 3, 4, 6, 7, 8, 9 OR not Present		
		Null	2 OR not Present		
	Null	Null	2 OR not Present		
1720	No ICEARE in Annex 1, Appendix 1.				
1721	No RADRFL in Annex 1, Appendix 1.				
1722a	For each navigational aid equipment feature object which is not a slave to a navigational aid structure object OR another navigational aid equipment object.	Equipment object which is not a slave of a structure object or another equipment object.	Amend equipment object to slave.	N.1, O.1, O.2, O.4, P.1, Q.1	W
1722b	For each DAYMAR and daymar feature object that EQUALS another structure feature object AND is Not a slave to a structure feature object.	DAYMAR or daymar marked as structure object where another structure object exists.	Amend DAYMAR or daymar object to slave.	O.2.1, O.2.6, O.2.7, O.2.8	W
1723	For each feature object of geometric primitive point forming the same navigational aid which does not reference the same spatial object.	Object forming a navigational aid does not point to the same spatial object.	Ensure all components of the navigational aid point to the same spatial object.	N.1, O.1, O.2, O.4, P.1, Q.1	C
1724	For each navigational aid equipment feature object where OBJNAM is Equal to the OBJNAM of the structure feature object.	OBJNAM on navigational aid equipment object repeats that of the structure object.	Remove repeated OBJNAM value.	O.1, O.2, O.4, P.1	W
1725	<i>n.a. for IENCs.</i>				
1726	If the M_COVR meta object where CATCOV is Equal to 1 AND is Not equal to the combined coverage of m_nsys meta objects where marsys is notNull.	Data coverage not completely covered by m_nsys_objects with a value for marsys.	Ensure complete coverage of m_nsys objects with marsys populated.	C.1.1, C.1.3	C

No.	Check description	Check message	Check solution	Conformity to:	Cat.
1727	For each m_nsys meta object where marsys is notNull which OVERLAPS or is WITHIN another meta m_nsys_object where marsys is notNull.	m_nsys objects with marsys values overlap.	Amend limits of m_nsys objects to remove overlap.	C.1.3	C
1728	For each m_nsys meta object where ORIENT is notNull which OVERLAPS or is WITHIN another meta m_nsys object where ORIENT is notNull.	m_nsys objects with ORIENT values overlap.	Amend limits of m_nsys objects to remove overlap.	C.1.3	E
1729	For each feature object forming part of a BCNXXX, bcnxxx, boyxxx or BOYXXX feature object AND marsys is Not equal to 9 (no system) OR 10 (other system) where the attributes for structure, top mark and lights do not conform to the value of MARSYS or marsys of the feature object or the m_nsys meta object it is COVERED_BY.	Component of a navigational aid does not conform to the system defined by the MARSYS/marsys attribute of the underlying m_nsys_object.	Ensure navigational aid attributes conform to the system encoded in MARSYS or marsys.	C.1.3	E
1730	<i>No VERACC and VERDAT in Annex 1, Appendix 1 for BCNCAR.</i>				
1731	<i>No VERACC and VERDAT in Annex 1, Appendix 1 for BCNISD.</i>				
1732	<i>No VERACC and VERDAT in Annex 1, Appendix 1 for BCNLAT.</i>				
1733	<i>No VERACC and VERDAT in Annex 1, Appendix 1 for BCNSAW.</i>				
1734	<i>No VERACC and VERDAT in Annex 1, Appendix 1 for BCNSPP.</i>				
1735a	For each BCNXXX, boyxxx, BOYXXX feature object where MARSYS or marsys is Present AND is Equal to the value of marsys on the m_nsys meta object it is COVERED_BY.	Value of MARSYS or marsys on BCNXXX, boyxxx or BOYXXX object is the same as the value on m_nsys object.	Remove MARSYS/marsys from BCNXXX, boyxxx or BOYXXX object.	O.1, O.2	E

No.	Check description	Check message	Check solution	Conformity to:	Cat.
1735b	No MARSYS for LIGHTS in Annex 1, Appendix 1.				
1736	No VERACC and VERDAT for DAYMAR in Annex 1, Appendix 1.				
1737	No VERACC and VERDAT for BOYCAR in Annex 1, Appendix 1.				
1738	No BOYINB in Annex 1, Appendix 1.				
1739	No VERACC for BOYISD in Annex 1, Appendix 1.				
1740	No VERACC for BOYLAT in Annex 1, Appendix 1.				
1741	No VERACC for BOYSPP in Annex 1, Appendix 1.				
1742	No VERACC for BOYSAW in Annex 1, Appendix 1.				
	Check removed.				
1744	No LITVES in Annex 1, Appendix 1.				
1745	No LIFLT in Annex 1, Appendix 1.				
1746	No such attributes of TOPMAR in Annex 1, Appendix 1.				
1747	No RETRFL in Annex 1, Appendix 1.				
	Check removed.				
1749	rNo VERACC for LIGHTS in Annex 1, Appendix 1.				
1750	For each LIGHTS feature object which is a slave to a BOYXXX or boyxxx feature object AND HEIGHT is Present.	HEIGHT populated for a LIGHTS object which is slave to a buoy object.	Remove HEIGHT from LIGHTS object.	Logical consistency	E
1751	For each LIGHTS feature object where ORIENT is Present AND CATLIT does Not contain value 1 (directional function).	ORIENT populated without CATLIT = 1.	Remove ORIENT or populate appropriate value of CATLIT for LIGHTS object.	N.1	E

No.	Check description	Check message	Check solution	Conformity to:	Cat.
1752	For each LIGHTS feature object where LITCHR is Equal to 1 (fixed) AND SIGGRP, SIGPER or SIGSEQ is Present.	SIGGRP, SIGPER or SIGSEQ populated for LIGHTS object where LITCHR = 1.	Remove SIGGRP, SIGPER or SIGSEQ, not applicable to fixed lights.	N.1	E
	<i>Check removed.</i>				
1754	<i>No VERDAT for LIGHTS in Annex 1, Appendix 1.</i>				
1755	<i>No VERDAT for LIGHTS in Annex 1, Appendix 1.</i>				
1756	For each LIGHTS feature object where CATLIT Contains (4) [leading light] AND does not contain the value 1 (directional function) AND ORIENT is present.	ORIENT present for non-directional leading LIGHTS object.	Remove ORIENT from LIGHTS object.	N.1	E
1757	<i>No CATLIT 19 in Annex 1, Appendix 1.</i>				
1758	<i>No CATLIT 17 in Annex 1, Appendix 1.</i>				
1759	<i>No RDOSTA in Annex 1, Appendix 1.</i>				
1760	<i>No VERACC and VERDAT for RADSTA in Annex 1, Appendix 1.</i>				
1761	<i>No RDARFL in Annex 1, Appendix 1.</i>				
1762	<i>No RDARFL in Annex 1, Appendix 1.</i>				
	<i>Check removed.</i>				
1764	For each feature object where STATUS is Equal to 1 (permanent) AND PERSTA or PEREND is Present.	PERSTA or PEREND populated for an object with STATUS = 1.	Amend STATUS or remove PERSTA/PEREND	Logical consistency	E
1765a	If the cell contains both M_QUAL and M_ACCY meta objects AND their combined coverage is Not equal to the M_COVR objects with CATCOV Equal to 1 (coverage available).	M_QUAL or M_ACCY do not provide full coverage.	Amend M_QUAL or M_ACCY objects to provide full coverage.	No RDARFL in Annex 1, Appendix 1	W

No.	Check description	Check message	Check solution	Conformity to:	Cat.
1765b	For each M_QUAL meta object that CONTAINS, OVERLAPS OR is WITHIN a M_ACCY meta object.	M_QUAL and M_ACCY objects overlap.	Amend M_QUAL or M_ACCY objects to remove overlap.	Logical consistency	W
1766	For each PICREP, TXTDSC and NTXTDS attribute that contains more than one file name.	PICREP, TXTDSC or NTXTDS contains more than one file name.	Amend value of PICREP, TXTDSC or NTXTDS to only contain a single file name.	B	E
1767	<i>No WATLEV for SBDARE in Annex 1, Appendix 1.</i>				
1768	<i>n.a. for IENCs.</i>				
1769	<i>No EXPSOU for SOUNDG in Annex 1, Appendix 1.</i>				
1770a	<i>No EXPSOU for SOUNDG in Annex 1, Appendix 1.</i>				
1770b	<i>No EXPSOU for SOUNDG in Annex 1, Appendix 1.</i>				
1770c	<i>No EXPSOU for SOUNDG in Annex 1, Appendix 1.</i>				
1771	For each edge which is COINCIDENT with a DEPCNT feature object AND two DEPARE feature objects AND VALDCO is Not equal to the minimum DRVAL2.	Illogical value of VALDCO of a DEPCNT object between two DEPARE objects.	Amend VALDCO to a logical value for DEPCNT object.	Logical consistency	W
1772a	For each UWTRC and uwtrc feature object where VALSOU is notNull AND EXPSOU is Equal to 1 (within the range of depth of the surrounding depth area) OR not Present AND VALSOU is Less than or equal to DRVAL1 OR Greater than DRVAL2 of the DEPARE or depare feature object it is COVERED_BY.	VALSOU for UWTRC or uwtrc object with EXPSOU = 1 (within the range of depth of the surrounding depth area) or not present is outside the depth range of the underlying DEPARE object.	Populate appropriate value of EXPSOU for UWTRC/uwtrc object.	J.1.1	E

No.	Check description	Check message	Check solution	Conformity to:	Cat.
1772b	For each UWTRC and uwtrc feature object where VALSOU is notNull AND EXPSOU is Equal to 1 (within the range of depth of the surrounding depth area) OR not Present AND VALSOU is Less than or equal to DRVAL1 of the DRGARE feature object it is COVERED_BY.	VALSOU for UWTRC object with EXPSOU = 1 (within the range of depth of the surrounding depth area) or not present is outside the depth range of the underlying DRGARE object.	Populate appropriate value of EXPSOU for DRGARE object.	J.1.1	E
1773	For each UWTRC and uwtrc feature object where VALSOU is notNull AND EXPSOU is Equal to 2 (shoaler than the range of depth of the surrounding depth area) AND VALSOU is Greater than the value of DRVAL1 of the DEPARE, depare or DRGARE feature object it is COVERED_BY AND DRVAL1 is notNull.	UWTRC or uwtrc object with EXPSOU = 2 (shoaler than the range of depth of the surrounding depth area) and a VALSOU value deeper than the DRVAL1 of the underlying DEPARE or DRGARE object.	Remove EXPSOU or amend to EXPSOU = 1 (within the range of depth of the surrounding depth area) for UWTRC/uwtrc object.	J.1.1	W
1774a	For each UWTRC and uwtrc feature object where VALSOU is notNull AND EXPSOU is Equal to 3 (deeper than the range of depth of the surrounding depth area) AND the VALSOU is Less than or equal to DRVAL2 of the DEPARE or depare feature object it is COVERED_BY AND DRVAL2 is notNull.	UWTRC or uwtrc object with EXPSOU = 3 (deeper than the range of depth of the surrounding depth area) and a VALSOU value less than or equal to the DRVAL2 value of the underlying DEPARE or depare object.	Remove EXPSOU or amend to EXPSOU = 1 (within the range of depth of the surrounding depth area) for UWTRC/uwtrc object.	J.1.1	E
1774b	<i>No DRVAL2 for DRGARE in Annex 1, Appendix 1.</i>				

No.	Check description	Check message	Check solution	Conformity to:	Cat.	
1774c	For each UWTRC and uwtrc feature object where VALSOU is notNull AND EXSPOU is Equal to 3 (deeper than the range of depth of the surrounding depth area) AND VALSOU is Less than or equal to the DRVAL1 of the DRGARE feature object it is COVERED_BY.	UWTRC or uwtrc object with EXPSOU= 3 (deeper than the range of depth of the surrounding depth area) and with a VALSOU value less than or equal to the DRVAL1 of the underlying DRGARE object.	Amend EXPSOU = 2 (shoaler than the range of depth of the surrounding depth area) for UWTRC/uwtrc object.	J.1.1	E	
1775	For each navigational aid equipment feature object which is COVERED_BY a DEPARE, depare, DRGARE or UNSARE AND does not have a navigational aid structure feature object as a master AND the geometry of which is not COVERED_BY a bridge, CBLOHD, cblohd, COALNE, CONVYR, convyr, DAMCON, (with CATDAM Equal to 3 (flood barrage)), FLODOC, flodoc, LNDARE, MORFAC, PIPOHD, pipohd, PONTON, ponton, PYLONS, slcons or SLCONS feature object.	Equipment object within DEPARE, DRGARE or UNSARE without an appropriate supporting structure object or underlying object.	Ensure equipment object is encoded with an appropriate structure object or underlying object.	N.1, O.1, O.2	W	
1776	For each LIGHTS feature object where the value of LITCHR and SIGGRP are notNull AND the combination of values is not as listed in the table below.	Values of LITCHR and SIGGRP are not consistent.	Amend attributes in accordance with the logical values defined in the table.	N.1	W	
	LITCHR					SIGGRP
	6					(1)
	7					(1)
	9					()
	10					()
	11					()
	28					()

No.	Check description	Check message	Check solution	Conformity to:	Cat.									
1777	For each collection object which references feature objects which do not exist in the cell.	Collection object references objects which do not exist within the cell.	Remove invalid references.		E									
1778	For each LIGHTS feature object where CATLIT contains the value 1 (directional function) AND the value of the angle between SECTR1 and SECTR2 is Greater than 10.	LIGHTS object with CATLIT = 1 (directional function) with a sector arc greater than 10 degrees.	Amend SECTR1 or SECTR2, or remove CATLIT = 1 (directional function) for LIGHTS object.	N.1 and Annex 1, Appendix 1	W									
1779	For each DEPARE and depare feature object where DRVAL1 is Equal to DRVAL2.	DRVAL1 is equal to DRVAL2 for a DEPARE or depare object.	Amend DRVAL1 or DRVAL2 to logical values for DEPARE/depare object.	I.1 and Logical consistency	W									
1780	For each SBDARE feature object where NATSUR and NATQUA are notNull AND the combination of values are not as listed in the table below.	Illogical combination of NATSUR and NATQUA.	Amend NATSUR or NATQUA for SBDARE object in accordance with the logical values defined in the table.	Logical consistency	W									
						NATQUA	1	2	3	4	8	9	10	
						NATSUR								
						1								
						2								
						3								
						4	x	x	x					
						5								
						6								
						7								
						8								
						9								
18														

No.	Check description	Check message	Check solution	Conformity to:	Cat.
1781	For each BUISGL or LNDMRK feature object which is part of a Master to Slave relationship AND references a LIGHTS feature object as slave AND CATLIT is Not equal to 6 (air obstruction light) OR 8 (flood light) OR 9 (strip light) AND FUNCTN does not contain value 33 (light support).	BUISGL or LNDMRK object with a slave LIGHTS object without FUNCTN = 33 (light support)	Set FUNCTN to 33 (light support) for BUISGL or LNDMRK object.	E.1, F.2	W
1782	<i>No SWPARE in Annex 1, Appendix 1.</i>				
1783a	For each feature object of geometric primitive area where WATLEV or watlev is Equal to 4 (covers and uncovers) AND OVERLAPS OR is WITHIN a DEPARE or depare feature object where DRVAL1 is Greater than or equal to 0.	Area object with illogical value of WATLEV or watlev which is shoaler than the DRVAL1 value of the underlying DEPARE or depare object.	Populate appropriate value of WATLEV/watlev.	Logical consistency	E
1783b	For each feature object of geometric primitive area where WATLEV or watlev is Equal to 5 (awash) AND OVERLAPS OR is WITHIN a DEPARE or depare feature object where DRVAL1 is Greater than 0.	Area object with illogical value of WATLEV or watlev which is shoaler than the DRVAL1 value of the underlying DEPARE or depare object.	Populate appropriate value of WATLEV/watlev.	Logical consistency	E
1784	For each spatial object where the value of HORDAT, POSACC or QUAPOS is Null.	HORDAT, POSACC or QUAPOS populated with an unknown value.	Remove attribute from spatial object or populate with a known value.	Logical consistency	W
1785	For each feature object where CONDTN is Equal to 4 (wingless) AND CATLMK is Not equal to 18 (windmill) OR 19 (windmotor).	Object other than windmill or windmotor with CONDTN = 4 (wingless).	Remove value of CONDTN or use an appropriate LNDMRK object.	Logical consistency	W

No.	Check description	Check message	Check solution	Conformity to:	Cat.
1786	For each feature object of geometric primitive area where WATLEV or watlev is Equal to 2 (always dry) AND is not COVERED_BY a LNDARE feature object of geometric primitive area.	Area object with WATLEV or watlev = 2 not covered by a LNDARE object.	Amend WATLEV/watlev value or ensure object is on land.	Logical consistency	W
1787	For each NAVLNE feature object which is COINCIDENT with a RECTRC feature object AND the values of ORIENT which are Not equal OR reciprocal.	ORIENT values for NAVLNE and RECTRC objects sharing an edge are not equal or reciprocal.	Ensure values of ORIENT for NAVLNE and RECTRC agree or are reciprocal.	Logical consistency	E
1788	For each NAVLNE feature object which is COINCIDENT with a RECTRC feature object AND is not part of the same C_AGGR collection object.	NAVLNE and RECTRC objects share an edge but are not aggregated using C_AGGR.	Aggregate NAVLNE and RECTRC objects using C_AGGR object.	N.1.3	W
1789a	For each RECTRC feature object of geometric primitive line where ORIENT is notNull AND TRAFIC is Equal to 4 (two-way) AND the bearing of the line is more than 5 degrees Greater than OR Less than the value (or reciprocal value) of ORIENT.	RECTRC where the orientation of the geometry is not consistent with the value of ORIENT.	Populate an appropriate value of ORIENT consistent with the geometry of the RECTRC object.	Logical consistency	C
1789b	For each NAVLNE feature object where ORIENT is notNull AND the bearing of the line is more than 5 degrees Greater than OR Less than the value (or reciprocal value) of ORIENT.	NAVLNE where the orientation of the geometry is not consistent with the value of ORIENT.	Populate an appropriate value of ORIENT consistent with the geometry of the NAVLNE object.	Logical consistency	C
1790a	For each LIGHTS feature object where ORIENT is notNull AND SECTR1 OR SECTR2 is notNull.	LIGHTS object where ORIENT and SECTR1 or SECTR2 is populated.	Remove values of SECTR1 and SECTR2 or ORIENT from LIGHTS object.	Logical consistency	E

No.	Check description	Check message	Check solution	Conformity to:	Cat.
1790b	For each LIGHTS feature object where ORIENT is notNull AND it is aggregated to a RECTRC or NAVLNE feature object in a C_AGGR collection object.	LIGHTS object where ORIENT is populated and is aggregated with a NAVLNE or RECTRC object within a C_AGGR collection object.	Set ORIENT to Null for LIGHTS object.	Logical consistency	E
1790c	For each LIGHTS feature object where ORIENT is notNull AND the associated structure feature object is aggregated to a RECTRC or NAVLNE feature object in a C_AGGR collection object.	LIGHTS object where ORIENT is populated and the associated structure feature object is aggregated with a NAVLNE or RECTRC object within a C_AGGR collection object.	Set ORIENT to Null for LIGHTS object.	Logical consistency	E
1791a	For each NAVLNE feature object where CATNAV is Equal to 3 (leading line bearing a recommended track) AND is not COINCIDENT with a RECTRC where CATTRK is Equal to 1 (based on a system of fixed marks).	NAVLNE object with CATNAV = 3 (leading line bearing a recommended track) does not share the geometry of a RECTRC object with CATTRK = 1 (based on a system of fixed marks).	Encode RECTRC object with CATTRK = 1 (based on a system of fixed marks) coincident with NAVLNE object.	Logical consistency	E
1791b	For each RECTRC feature object where CATTRK is Equal to 1 (based on a system of fixed marks) AND is not COINCIDENT with a NAVLNE where CATNAV is Equal to 3 (leading line bearing a recommended track).	RECTRC object with CATTRK = 1 (based on a system of fixed marks) does not share the geometry of a NAVLNE object with CATNAV = 3 (leading line bearing a recommended track).	Encode NAVLNE object with CATNAV = 3 (leading line bearing a recommended track) coincident with RECTRC object.	Logical consistency	E

No.	Check description	Check message	Check solution	Conformity to:	Cat.
1792	If the cell crosses the 180° meridian.	Cell crosses the 180° meridian.	Split the cell at the 180° meridian.	Encoding Bulletin EB18	C
1793	For each Master to Slave relationship which references more than one LIGHTS feature object AND all of the LIGHTS feature objects are encoded with LITVIS is Equal to 7 (obscured).	Group of LIGHTS objects where all are LITVIS = 7 (obscured).	Confirm values of LITVIS for LIGHTS objects or encode primary light.	Logical consistency	E
1794	For each LIGHTS feature object where CATLIT is equal to 1 (directional function) AND is a slave in a Master to Slave relationship AND the master feature object is any of BOYXXX or MORFAC (where CATMOR is Equal to 7 (mooring buoy)).	Directional light is a slave to a BOYXXX, MORFAC master object (with CATMOR = 7 (mooring buoy)).	Amend master to a logical object or remove value of CATLIT for LIGHTS object.	Logical consistency	E
1795a	For each feature object which is a slave in a Master to Slave relationship AND where DATSTA OR PERSTA attributes are notNull AND the values of DATSTA OR PERSTA are Less than the values of DATSTA OR PERSTA encoded on the master object.	Temporal attributes on a slave object extend beyond those on the master object.	Populate appropriate temporal attributes on master/slave objects.	Logical consistency	C
1795b	For each feature object which is a slave in a Master to Slave relationship AND where PEREND OR DATEND attributes are notNull AND the values of PEREND OR DATEND are Greater than the values of PEREND OR DATEND encoded on the master object.	Temporal attributes on a slave object extend beyond those on the master object.	Populate appropriate temporal attributes on master/slave objects.	Logical consistency	C
	<i>Check removed.</i>				
1797	For each of the feature object class, geometry and attribute combinations in the table below.		Object, geometry and attribute combinations which do not display in Inland ECDIS.	Remove objects which do not display in Inland ECDIS or use alternative encoding.	E
	Object	Geometry	Attributes		
	GRIDRN	P			
	RUNWAY	P			

No.	Check description	Check message	Check solution	Conformity to:	Cat.
1798	For each value of INFORM OR NINFOM which contains more than 300 characters.	INFORM or NINFOM contains more than 300 characters.	Amend value of INFORM or NINFOM or use TXTDSC or NTXTDS if appropriate.		E
1799	For each bridge feature object where VERCCL or VERCOP are notNull AND CATBRG is Not equal to 4 (lifting bridge) OR 5 (bascule bridge) OR 7 (draw bridge).	bridge object has values of VERCCL or VERCOP without appropriate value of CATBRG.	Ensure appropriate value of CATBRG is populated for bridge object.	Logical consistency	W
1800	For each bridge feature object where VERCLR is notNull AND CATBRG is Equal to 4 (lifting bridge) OR 5 (bascule bridge) OR 7 (draw bridge).	VERCLR populated for bridge object with an inappropriate value of CATBRG.	Ensure appropriate value of CATBRG is populated.	Logical consistency	W
	<i>Check removed.</i>				
	<i>Check removed.</i>				
1803	For each Master to Slave relationship where referenced feature objects have been populated with different values of SCAMIN.	Objects which are in a Master to Slave relationship with different values of SCAMIN.	Amend values of SCAMIN to agree.	Logical consistency	W
1804	For each OBSTRN, UWTRC, uwtrc or WRECKS feature object of geometric primitive point which TOUCHES an edge of a DEPARE, depare, DRGARE or UNSARE feature object.	Point object touches an edge between Group 1 objects.	Amend Group 1 object geometry so that it does not touch the point object.		C
1805	<i>Allowed for IENCs.</i>				
1806	For each CTNARE feature object of geometric primitive area which is COINCIDENT with a DEPCNT feature object.	Area CTNARE object shares geometry with DEPCNT.	Amend the CTNARE object geometry so that it is not coincident with the DEPCNT object.	Visibility	W

No.	Check description	Check message	Check solution	Conformity to:	Cat.
1807	For each BOYXXX feature object OR MORFAC feature object where CATMOR is Equal to 7 (mooring buoy) which is COVERED_BY a FLODOC, HULKES, LNDARE, PONTON or SLCONS feature object where WATLEV is Equal to 2 (always dry).	A floating navigational aid captured over land.	Reposition object over water feature.	Logical consistency	W
1808	<i>n.a. for IENCs.</i>				
	<i>Check removed.</i>				
	<i>Check removed.</i>				
i1552	For each DEPARE and depare feature with QUASOU=8 (reported) and neither DRVAL1 nor DRVAL2 Present.	DEPARE or depare with reported depth, but without depth value.	Populate DRVAL1 and/or DRVAL2 of DEPARE/depare	Logical consistency	E
i1553	For each curent feature with none of the velocity attributes (curvhw, curvlw, curvmw, curvow) Present	curent object without velocity information	Populate at least one of the attributes curvhw, curvlw, curvmw, curvow of curent	H.1.1, logical consistency	W
i1554	For each curent feature of geometric primitive area with value for attribute direction of impact (dirimp) Not Present	curent area object without direction of impact	Populate dirimp of curent	H.1.1	W
i1555	For each curent feature of geometric primitive point with value of attribute ORIENT Not Present	curent point object without ORIENT	Populate ORIENT of curent	H.1.1	W
i1556	For each curent feature with water level name attribute Present AND the corresponding velocity attribute Not Present: hignam without curvhw lownam without curvlw meanam without curvmw othnam without curvow	curent feature without velocity information for an encoded water level	Populate curvhw if hignam is encoded, curvlw if lownam is encoded, curvmw if meanam is encoded, curvow if othnam is encoded	H.1.1	E

3.5 Checks relating to allowable attribute values for particular feature object classes

No.	Check description	Check message	Check solution	Conformity to:	Cat.
i2000	For each feature object where an attribute of type "L" (list) or type "E" (enumerated) is Present AND contains a value that is not listed in the Annex 1, Appendix 1 for the given feature object class.	Attribute value which is not permitted on an object.	Remove disallowed attribute value.	Annex 1, Appendix 1	E

ANNEX 5
COMPARISON OF THE STRUCTURES OF THE STANDARD FOR MARITIME ECDIS AND OF ES-RIS

Maritime ECDIS	ES-RIS	OPEN ECDIS FORUM https://ienc.openecdis.org
<p>REF#IMO-MSC232 revised Performance Standards for ECDIS, December 2006</p> <p>Appendix 1: Reference documents</p> <p>Appendix 2: SENC Information available for display during route planning and route monitoring</p> <p>Appendix 3: Navigational elements and parameters</p> <p>Appendix 4: Areas for which special conditions exist</p> <p>Appendix 5: Alarms and indicators</p> <p>Appendix 6: Back-up requirements</p> <p>Appendix 7: Raster Chart Display System (RCDS), mode of operation</p>	<p>Part I, Chapter 1: General provisions and references</p> <p>Part I, Chapter 2: General requirements and specifications of Inland ECDIS</p> <p>Part I, Chapter 3: System configurations (Figures)</p>	
<p>REF#IHO-S57: Transfer Standard for Digital Hydrographic Data, Edition 3.1, Supplement No 2, June 2009</p> <p>Part 1: General Introduction</p> <p>Part 2: Theoretical Data Model</p> <p>Part 3: Data Structure</p>	<p>Part I, Chapter 4: Data Standard for IENCs</p>	
<p>Appendix A: IHO Object catalogue</p> <p>Introduction</p> <p>Chapter 1: Object Classes</p> <p>Chapter 2: Attributes</p> <p>Annex B: Attributes/Object Classes Cross Reference</p>		<p>IENC Feature Catalogue</p> <p>Bathymetric IENC Feature Catalogue</p>

Maritime ECDIS	ES-RIS	OPEN ECDIS FORUM https://ienc.openecdis.org
Appendix B: Product specifications Appendix B.1: ENC Product specification Annex A: Use of the Object Catalogue for ENC Annex B: Example of Cyclic Redundancy Check (CRC) Coding Appendix B.2: IHO Object Catalogue Data Dictionary Product Specification		Product Specification for IENCs Product Specification for bathymetric IENCs IENC Encoding Guide
REF# IHO-S62 ENC Producer Codes, Edition 2.5, December 2009		Codes for Producers and Waterways
REF# IHO-S52 Specification for Chart Content and Display Aspects of ECDIS, Edition 6, March 2010 Annex A: IHO ECDIS presentation library Annex B: Procedure for initial calibration of colour displays Annex C: Procedure for maintaining the calibration of displays Appendix 1: Guidance on updating the electronic chart Annex A: Definitions and acronyms Annex B: Current updating practice for paper charts Annex D: Estimate of data volume	Part I, Chapter 6: Presentation Standard for Inland ECDIS	Presentation Library for Inland ECDIS Look-up tables Symbols Conditional Symbology Procedures
REF# IEC-61174 Edition 3.0 : ECDIS - Operational and Performance Requirements, Methods of Testing and Required Test Results, 2008-09	Part V	
REF# IHO-S32 Appendix 1 : Hydrographic Dictionary – Glossary of ECDIS-Related Terms	Part 0, Chapter 2: Definitions	

***ANNEX 6
(LEFT VOID)***

***ANNEX 7
(LEFT VOID)***

***ANNEX 8
(LEFT VOID)***

European Committee for drawing up Standards in the field of Inland Navigation
(CESNI)

Edition 2025/1

**EUROPEAN STANDARD FOR RIVER INFORMATION SERVICES
ANNEXES**

Annexes 9 to 18

ANNEX 9

DIGITAL INTERFACE SENTENCES FOR INLAND AIS

1. Input sentences

The serial digital interface of the AIS is supported by existing REF#IEC-61162 sentences. The detailed descriptions for the digital interface sentences are found in REF#IEC-61162.

In addition the following digital interface sentences are defined for Inland AIS mobile station.

2. Inland waterway static vessel data

This sentence is used to change settings, which are not covered by SSD and VSD.

\$PIWWSSD,cccccccc,xxxx,x.x,x.x,x.x,x.x,x.x,x.x,x.x*hh<CR><LF>

field 1 2 3 4 5 6 7 8 9 10 11

Field	Format	Description
1	cccccccc	ENI
2	xxxx	Inland vessel type according to Annex 10
3	x.x	Length of vessel 0 to 800,0 metre
4	x.x	Beam of vessel 0 to 100,0 metre
5	x	Quality of speed information 1 = high or 0 = low
6	x	Quality of course information 1 = high or 0 = low
7	x	Quality of heading information 1 = high or 0 = low
8	x.x	B value for internal reference position (distance reference point to stern)
9	x.x	C value for internal reference position (distance reference point to port side)
10	x.x	B value for external reference position (distance reference point to stern)
11	x.x	C value for external reference position (distance reference point to port side)

3. Inland waterway voyage data

This sentence is used to enter inland navigation voyage vessel data into an Inland AIS mobile station. For setting the inland voyage related data the sentence \$PIWWIVD with the following content is used.

\$PrWWIVD,x,x,x,x,x,x,x,xxx,xxxx,xxx,x.x,x.x,x.x,x.x*hh<CR><LF>

field 1 2 3 4 5 6 7 8 9 10 11 12 13

Field	Format	Description
1	x	See REF#ITU-R1371 Msg 23 reporting interval settings, default setting: 0
2	x	Number of blue cones: 0-3, 4 = B-Flag, 5 = default = unknown
3	x	0 = not available = default, 1 = loaded, 2 = unloaded, rest not used
4	x.x	Static draught of vessel 0 to 20,00 metres, 0 = unknown = default, rest not used
5	x.x	Air draught of vessel 0 to 40,00 metres, 0 = unknown = default, rest not used
6	x	Number of assisting tugboats 0-6, 7 = default = unknown, rest not used
7	xxx	Number of crew members on board 0 to 254, 255 = unknown = default, rest not used
8	xxxx	Number of passengers on board 0 to 8190, 8191 = unknown = default, rest not used
9	xxx	Number of shipboard personnel on board 0 to 254, 255 = unknown = default, rest not used
10	x.x	Convoy extension to bow in (metre.decimetre = resolution in dm)
11	x.x	Convoy extension to stern in (metre.decimetre = resolution in dm)
12	x.x	Convoy extension to port side in (metre.decimetre = resolution in dm)
13	x.x	Convoy extension to starboard side in (metre.decimetre = resolution in dm)

In case of null fields the corresponding configuration setting shall not be changed.

ANNEX 10

INLAND VESSEL AND CONVOY TYPES

This correspondence table is based on an excerpt of the 'Codes for Types of Means of Transport' according to recommendation 28 of UNECE, revision 3¹ (2010) and the maritime ship types as defined in REF#ITU-R1371 'Technical characteristics for a universal shipborne automatic identification system using time division multiple access in the VHF maritime mobile band'.

Inland vessel and convoy type		Maritime ship type	
code	Vessel name	1st digit	2nd digit
8000	Vessel, type unknown	9	9
8010	Motor freighter	7	9
8020	Motor tanker	8	9
8021	Motor tanker, liquid cargo, type N	8	0
8022	Motor tanker, liquid cargo, type C	8	0
8023	Motor tanker, dry cargo as if liquid (e.g. cement)	8	9
8030	Container vessel	7	9
8040	Gas tanker	8	0
8050	Motor freighter, tug	7	9
8060	Motor tanker, tug	8	9
8070	Motor freighter with one or more vessels alongside	7	9
8080	Motor freighter with tanker	8	9
8090	Motor freighter pushing one or more freighters	7	9
8100	Motor freighter pushing at least one tank-vessel	8	9
8110	Tug, freighter	7	9
8120	Tug, tanker	8	9
8130	Tug, freighter, coupled	3	1
8140	Tug, freighter/tanker, coupled	3	1
8150	Freightbarge	9	9
8160	Tankbarge	9	9
8161	Tankbarge, liquid cargo, type N	9	0
8162	Tankbarge, liquid cargo, type C	9	0
8163	Tankbarge, dry cargo as if liquid (e.g. cement)	9	9

¹ The latest revision is REF#UNECE-R28 (see Part 0, Chapter 3).

Inland vessel and convoy type		Maritime ship type	
code	Vessel name	1st digit	2nd digit
8170	Freightbarge with containers	8	9
8180	Tankbarge, gas	9	0
8210	Pushtow, one cargo barge	7	9
8220	Pushtow, two cargo barges	7	9
8230	Pushtow, three cargo barges	7	9
8240	Pushtow, four cargo barges	7	9
8250	Pushtow, five cargo barges	7	9
8260	Pushtow, six cargo barges	7	9
8270	Pushtow, seven cargo barges	7	9
8280	Pushtow, eighth cargo barges	7	9
8290	Pushtow, nine or more barges	7	9
8310	Pushtow, one tank/gas barge	8	0
8320	Pushtow, two barges at least one tanker or gas barge	8	0
8330	Pushtow, three barges at least one tanker or gas barge	8	0
8340	Pushtow, four barges at least one tanker or gas barge	8	0
8350	Pushtow, five barges at least one tanker or gas barge	8	0
8360	Pushtow, six barges at least one tanker or gas barge	8	0
8370	Pushtow, seven barges at least one tanker or gas barge	8	0
8380	Pushtow, eight barges at least one tanker or gas barge	8	0
8390	Pushtow, nine or more barges at least one tanker or gas barge	8	0
8400	Tug, single	5	2
8410	Tug, one or more tows	3	1
8420	Tug, assisting a vessel or linked combination	3	1
8430	Pushboat, single	9	9
8440	Passenger vessel, ferry, red cross vessel, cruise vessel	6	9
8441	Ferry	6	9
8442	Red cross vessel	5	8
8443	Cruise vessel	6	9

Inland vessel and convoy type		Maritime ship type	
code	Vessel name	1st digit	2nd digit
8444	Passenger vessel without accommodation	6	9
8445	Day-trip high speed vessel	6	9
8446	Day-trip hydrofoil vessel	6	9
8447	Sailing cruise vessel	6	9
8448	Sailing passenger vessel without accommodation	6	9
8450	Service vessel, police patrol, port service	9	9
8451	Service vessel	9	9
8452	Police patrol vessel	5	5
8453	Port service vessel	9	9
8454	Navigation surveillance vessel	9	9
8460	Vessel, work maintenance craft, floating derrick, cable-vessel, buoy- vessel, dredge	3	3
8470	Object, towed, not otherwise specified	9	9
8480	Fishing boat	3	0
8490	Bunkervessel	9	9
8500	Barge, tanker, chemical	8	0
8510	Object, not otherwise specified	9	9
1500	General cargo Vessel maritime	7	9
1510	Unit carrier maritime	7	9
1520	Bulk carrier maritime	7	9
1530	Tanker	8	0
1540	Liquefied gas tanker	8	0
1850	Pleasure craft, longer than 20 metres	3	7
1900	Fast vessel	4	9
1910	Hydrofoil	4	9
1920	Catamaran fast	4	9

ANNEX 11
(INFORMATIVE) BLOCK DIAGRAM OF AIS

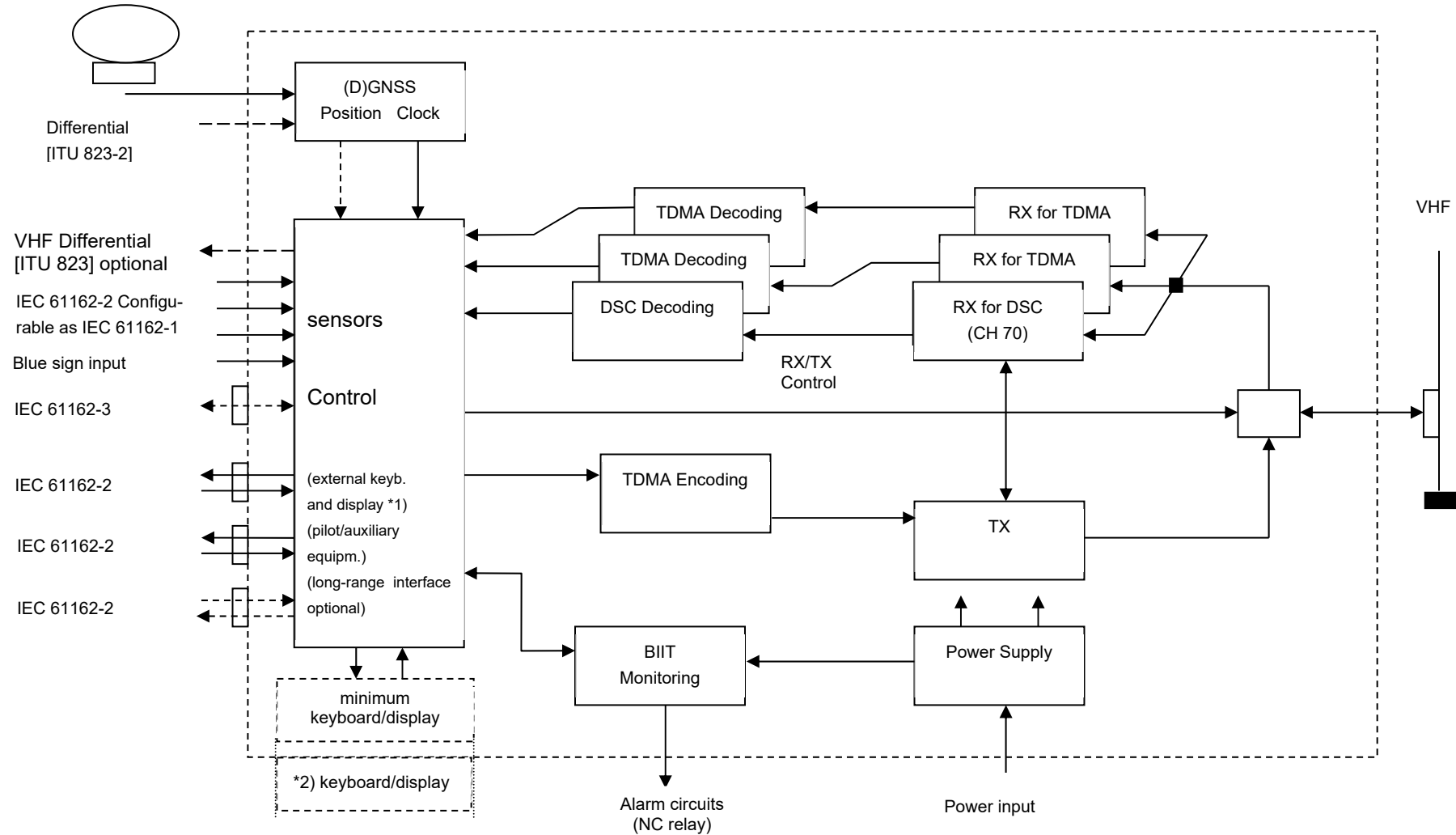

*1) The external keyboard/display may be e.g. a radar, ECDIS or dedicated devices.

*2) The internal keyboard/display may be optionally

ANNEX 12 (NORMATIVE) AIS INTERFACE OVERVIEW

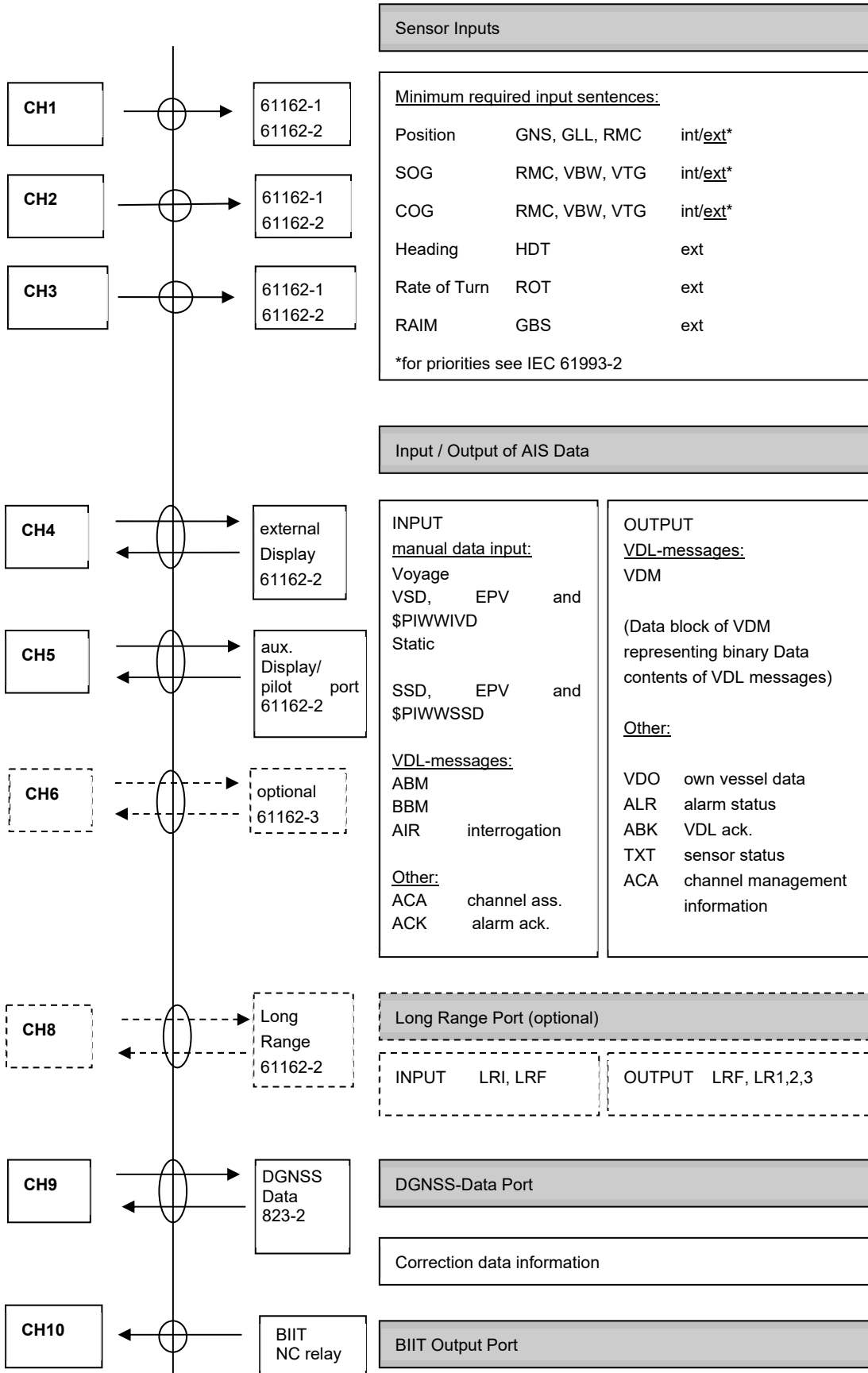

ANNEX 13
(NORMATIVE) ADDITIONAL PI PORT SENTENCES FOR INLAND AIS

1. Inland Waterway voyage data

\$PIWWIVD,x,x,x,x,x,x,x,x,xxx,xxxx,xxx,x.x,x.x,x.x,x.x*hh<CR><LF>

field 1 2 3 4 5 6 7 8 9 10 11 12 13

Field	Format	Description
1	x	See REF#ITU-R1371 message 23 for Reporting interval settings, default setting: 0
2	x	Number of blue cones: 0-3, 4=B-Flag, 5=default=unknown
3	x	0=not available=default, 1=loaded, 2=unloaded, rest not used
4	x.x	Static draught of vessel 0 to 20,00 meters, 0=unknown=default, rest not used
5	x.x	Air draught of vessel 0 to 40,00 meters, 0=unknown=default, rest not used
6	x	Number of assisting tugboat 0-6, 7=default=unknown, rest not used
7	xxx	Number of crew members on board 0 to 254, 255=unknown=default, rest not used
8	xxxx	Number of passengers on board 0 to 8190, 8191=unknown=default, rest not used
9	xxx	Number of shipboard personnel on board 0 to 254, 255=unknown=default, rest not used
10	x.x	Convoy extension to bow in (meter.decimeter = resolution in dm)
11	x.x	Convoy extension to stern in (meter.decimeter = resolution in dm)
12	x.x	Convoy extension to port side in (meter.decimeter = resolution in dm)
13	x.x	Convoy extension to starboard side in (meter.decimeter = resolution in dm)

In case of null fields, the corresponding configuration setting shall not be changed.

2. Inland Waterway Static Vessel data

This sentence is used to change settings, which are not covered by SSD and VSD.

\$PIWWSSD,ccccccc,xxxx,x.x,x.x,x.x,x.x,x.x,x.x,x.x*x*hh<CR><LF>

field 1 2 3 4 5 6 7 8 9 10 11

Field	Format	Description
1	ccccccc	ENI
2	xxxx	Inland vessel and convoy type (see Annex 10)
3	x.x	Length of vessel 0 to 800,0 meter
4	x.x	Beam of vessel 0 to 100,0 meter
5	x	Quality of speed information 1=high or 0=low
6	x	Quality of course information 1=high or 0=low
7	x	Quality of heading information 1=high or 0=low
8	x.x	B value for internal reference position (distance reference point to stern)
9	x.x	C value for internal reference position (distance reference point to port side)
10	x.x	B value for external reference position (distance reference point to stern)
11	x.x	C value for external reference position (distance reference point to port side)

ANNEX 14 VESSEL DIMENSIONS

Figure 14-1
Parameters and the usage to calculate the dimensions for both RFM 10 and message 5

Input parameters using IWWSSD: (own vessel)
Password protected
BI (dm) and LS (dm)
CI (dm) and BS (dm)

Input parameters using SSD:
(own vessel)
Password protected
AI (=A_{SSD}), BI (=B_{SSD}), CI (=C_{SSD}), DI (=D_{SSD}) (dm)

Input parameters using EPV and IWWIVD:
(convoy extension)
Not password protected
EA (dm)
EB (dm)
EC (dm)
ED (dm)

Calculated internally:
Using IWWSSD
 $AI (dm) = LS - BI$
 $DI (dm) = BS - CI$
 $BC (dm) = BS + EC + ED$
 $LC (dm) = LS + EA + EB$

Using SSD
 $LC (dm) = AI + EA + BI + EB$
 $BC (dm) = CI + EC + DI + ED$

$A (m) = AI + EA$ (rounded upwards)
 $B (m) = BI + EB$ (rounded upwards)
 $C (m) = CI + EC$ (rounded upwards)
 $D (m) = DI + ED$ (rounded upwards)

Output Msg 5:

A (m)
B (m)
C (m)
D (m)

Output RFM 10:

LC (dm)
BC (dm)

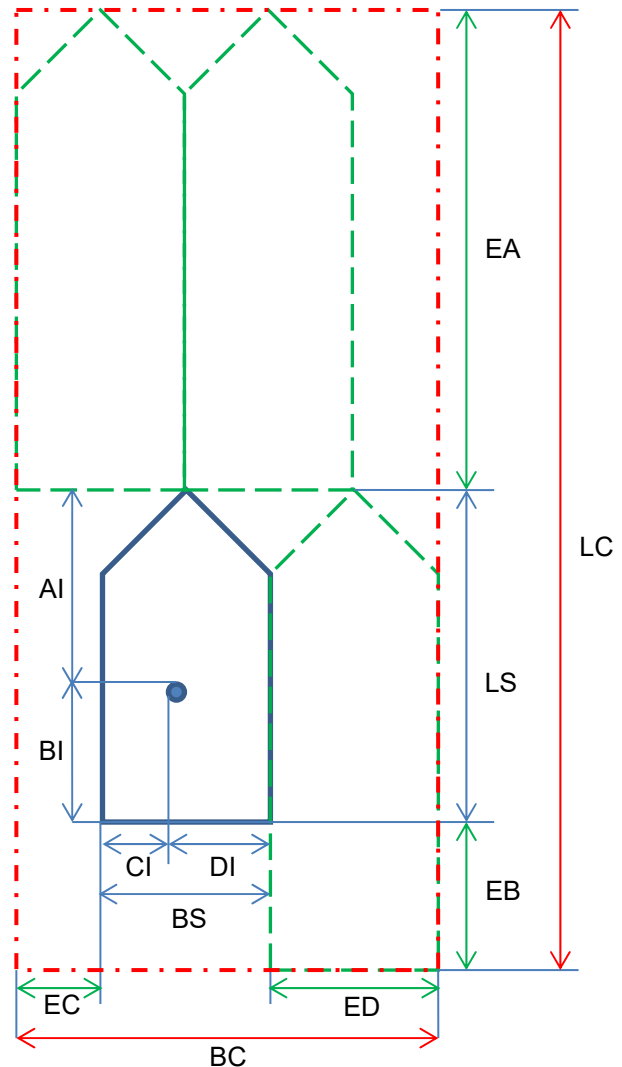

ANNEX 15 INLAND AIS MESSAGES

TABLE OF CONTENTS

1.	OVERVIEW OF INLAND APPLICATION SPECIFIC MESSAGES (ASM).....	475
2.	OPTIONAL APPLICATION SPECIFIC MESSAGES SENT FROM INLAND AIS MOBILE STATIONS.....	476
2.1	CONVOY MESSAGE (INLAND SPECIFIC MESSAGE FI 11)	476
2.2	INLAND CAPABILITY REPLY FROM EXTERNAL APPLICATION (INLAND SPECIFIC MESSAGE FI 4).....	477
2.3	ESTIMATED TIME OF ARRIVAL (ETA) MESSAGE (INLAND SPECIFIC MESSAGE FI 21).....	478
3.	OPTIONAL APPLICATION SPECIFIC MESSAGES SENT FROM AIS SHORE STATIONS.....	480
3.1	CONTROL MESSAGE (INLAND SPECIFIC MESSAGE (FI 1)	480
3.2	INLAND CAPABILITY INTERROGATION TO EXTERNAL APPLICATION (INLAND SPECIFIC MESSAGE FI 3).....	482
3.3	REQUESTED TIME OF ARRIVAL (RTA) MESSAGE (INLAND SPECIFIC MESSAGE FI 22)	483
3.4	PRESENT BRIDGE CLEARANCE MESSAGE (INLAND SPECIFIC MESSAGE FI 25)	484
3.5	WATER LEVEL MESSAGE (INLAND SPECIFIC MESSAGE FI 26)	486
3.6	SIGNAL STATION MESSAGE (INLAND SPECIFIC MESSAGE FI 41).....	487
3.7	GEOGRAPHIC NOTICE (INLAND SPECIFIC MESSAGE FI 42)	492
3.8	ISRS TEXT MESSAGE (INLAND SPECIFIC MESSAGE FI 44).....	511
Appendix 1	Convoy formation codes (Distributed separately)	

Index of tables

TABLE 15-1 OVERVIEW OF INLAND AIS ASM	475
TABLE 15-2 CONVOY MESSAGE REPORT	476
TABLE 15-3 INLAND CAPABILITY REPLY	477
TABLE 15-4 ETA REPORT	478
TABLE 15-5 LIST OF VIRTUAL MMSI NUMBERS	479
TABLE 15-6 CONTROL REPORT	480
TABLE 15-7 INLAND CAPABILITY INTERROGATION	482
TABLE 15-8 REQUESTED TIME OF ARRIVAL	483
TABLE 15-9 PRESENT BRIDGE CLEARANCE MESSAGE.....	484
TABLE 15-10 WATER LEVEL MESSAGE.....	486
TABLE 15-11 SIGNAL STATION MESSAGE.....	487
TABLE 15-12 GEOGRAPHIC NOTICE MESSAGE (BROADCASTED MESSAGE).....	492
TABLE 15-13 GEOGRAPHIC NOTICE MESSAGE (ADDRESSED MESSAGE).....	494
TABLE 15-14 NUMBER OF SUB-AREA TRANSMITTED	496
TABLE 15-15 SUB-AREAS.....	496
TABLE 15-16 CIRCLE OR ACCURATE POLYLINE/POLYGON	498
TABLE 15-17 RECTANGLE OR LINE OR POINT	500
TABLE 15-18 SECTOR.....	501
TABLE 15-19 POLYLINE.....	503
TABLE 15-20 ASSOCIATED TEXT.....	506
TABLE 15-21 NOTICE DESCRIPTION.....	506
TABLE 15-22 ISRS TEXT MESSAGE DESCRIPTION (BROADCAST MESSAGE).....	511
TABLE 15-23 ISRS TEXT MESSAGE DESCRIPTION (ADDRESSED MESSAGE).....	512

Index of figures

FIGURE 15-1 SIGNAL FORMS	490
FIGURE 15-2 LIGHT STATUS	491
FIGURE 15-3 CIRCLE DIAGRAM	499
FIGURE 15-4 CODING OF POINT, POLYLINES AND POLYGONS USING CIRCLE SUB-AREAS.....	499
FIGURE 15-5 RECTANGLE DIAGRAM	501
FIGURE 15-6 SECTOR DESCRIPTION	502
FIGURE 15-7 EXAMPLE OF A SINGLE POLYLINE (AREA SHAPE = 3, LINK = 0).....	504
FIGURE 15-8 GRAPHIC DEPICTION OF (1) ICE BOUNDARY BETWEEN SEA ICE AND OPEN WATER, AND (2) RECOMMENDED ROUTE THROUGH THE SEA ICE AREA.....	505
FIGURE 15-9 A GRAPHIC DEPICTION OF A STORM FRONT MESSAGE.....	505

1. Overview of Inland Application Specific Messages (ASM)

Table 15-1
Overview of Inland AIS ASM

FI ¹	Version	Name of regional function message	Sent by	Broadcast	Addressed	Implemented in Inland AIS station
1	1	Control Message	Shore	X		
3	0	Inland Capability Interrogation	Shore		X	
4	0	Inland Capability Interrogation reply	Vessel		X	
10	.. ²	Inland Vessel static and voyage related data	Vessel	X		X
11	0	Convoy Message	Vessel	X		
21	.. ²	ETA at lock/bridge/Terminal	Vessel		X	
22	.. ²	RTA at lock/bridge/Terminal	Shore		X	
25	2	Present Bridge Clearance	Shore	X		
26	0	Water level	Shore	X		
41	1	Signal Station	Shore	X		
42	0	Geographic Notice	Shore	X	X	
44	1	ISRS Text message	Shore	X	X	
55	.. ²	Inland number of persons on board	Vessel	X	X	X

1 FI ranges: 1-9 = system messages, 10-19 = general ship-borne use, 20-39 = VTS/VTM use, 40-54 = AtoN use, 55-63 = Search and Rescue use

2 no version indicator available

2. Optional Application Specific Messages sent from Inland AIS mobile stations
- 2.1 Convoy Message (Inland specific message FI 11)

Table 15-2
Convoy message report

Parameter	Bits	Description	
Message ID	6	Identifier for Message 8; always 8	
Repeat Indicator	2	Used by the repeater to indicate how many times a message has been repeated. Default = 0; 3 = do not repeat any more	
Source ID	30	MMSI number	
Spare	2	Not used, should be set to zero, reserved for future use	
Binary data	Application Identifier	16	DAC = 200, FI = 11
	Version indicator	3	The version number of the message default = 0, other values for future use
	Formation Code	9	Bit- coded convoy formation type (see formation code XML)
	ENI (Barge 1)	27	Bit-coded ENI 0 = default = not used, 11111111 to 99999999, other values not used
	Load condition (Barge 1)	2	0 = unknown = default, 1 = loaded, 2 = unloaded, 3 = loaded with dangerous cargo
	ENI (Barge 2)	27	Bit-coded ENI 0 = default = not used, 11111111 to 99999999, other values not used
	Load condition (Barge 2)	2	0 = unknown = default, 1 = loaded, 2 = unloaded, 3 = loaded with dangerous cargo
	Spare	n ¹	Not used. Should be set to zero, reserved for future use
Total	max 424	Occupies 1 or 2 slots	

Additional information / usage notes

- a) The message shall be sent by vessels only.
- b) The control status of the message is default off.
- c) The timeout should be 18 minutes (3 times the reporting rate).
- d) The reporting rate should be 6 minutes.

¹ This need to be calculated depending on the number of barges.

- e) The input of the loading status is optional.
- f) Additional barge information (ENI and loading condition) can be added as necessary.
- g) The application creating the convoy message shall check that the formation code and the number of barge data (ENI and loading status) transmitted in the message match.
- h) Up to three barges can be transmitted in a single-slot message.
- i) Up to ten barges can be transmitted in a two-slot message.
- j) The XML file provided in Appendix 1 provides the details how to interpret the convoy code.
- k) The timeout cannot be set by the control message.
- l) The reporting rate cannot be set by the control message.

2.2 Inland Capability reply from external application (Inland specific message FI 4)

**Table 15-3
Inland Capability Reply**

Parameter	Bits	Description	
Message ID	6	Identifier for Message 6; always 6, ack needed	
Repeat Indicator	2	Used by the repeater to indicate how many times a message has been repeated. See REF#ITU-R1371a; § 4.6.1, 0-3; 0 = default; 3 = do not repeat any more	
Source ID	30	MMSI number of source station	
Sequence number	2	0 – 3; see REF#ITU-R1371a, § 5.3.1.	
Destination MMSI	30	MMSI number of destination station.	
Retransmit flag	1	Retransmit Flag. 0 = no retransmission = default; 1 = retransmitted.	
Spare	1	Not used, should be set to zero, reserved for future use	
Binary data	Designated Area Code	10	DAC=200
	Function Identifier	6	FI=4
	Version indicator	3	The version number of the message default = 0, other values for future use
	Provided DAC code	10	DAC (default = 200)
	FI availability	192	FI capability table, triplets of three consecutive bits should be used for every FI, in the order FI 0, FI 1, ... FI 63. The use of bits per triplet: xxx per FI: 000 = FI (ASM) is not implemented = default 001 to 111 = value for "version of ASM" (value = version number as provided in the ASM + 1); example: value 001 = FI (ASM) is implemented in version 0, value 111 = FI (ASM) is implemented in version 7 or 8
	Spare	59	Not used, should be set to zero, reserved for future use
Total	352	2 slot message	

Additional information / usage notes:

- a) The message shall be sent by vessels only.
- b) The control status of the message is default on.
- c) The reporting rate should be on event.
- d) The timeout is undefined.
- e) This broadcast message from vessel is always available and cannot be influenced by the control message.

2.3 Estimated Time of Arrival (ETA) message (Inland specific message FI 21)

**Table 15-4
ETA report**

Parameter	Bit	Description	
Message ID	6	Identifier for Message 8; always 8	
Repeat Indicator	2	Used by the repeater to indicate how many times a message has been repeated. Default = 0; 3 = do not repeat any more	
Source ID	30	MMSI number of source station	
Sequence Number	2	0 – 3	
Destination ID	30	MMSI number of destination station	
Retransmit Flag	1	Retransmit Flag should be set upon retransmission: 0 = no retransmission = default; 1 = retransmitted.	
Spare	1	not used. Should be set to zero, reserved for future use	
Binary data	Application Identifier	16	DAC = 200 FI = 21
	UN country code	12	2*6 Bit characters, "00"= unknown; characters 1 and 2 of the ISRS Location Code
	UN location code	18	3*6 Bit characters, "000"= unknown; characters 3 to 5 of the ISRS Location Code
	Fairway section code	30	5*6 Bit characters, "00000"= unknown; characters 6 to 10 of the ISRS Location Code
	Object reference code	30	5*6 Bit characters, "00000"= unknown; characters 11 to 15 of the ISRS Location Code
	Fairway hectometre	30	5*6 Bit characters, "00000"= unknown; characters 16 to 20 of the ISRS Location Code
	ETA at lock/bridge/terminal	20	Estimated Time of Arrival; MMDDHHMM UTC Bits 19 - 16: month; 1 - 12; 0 = not available = default; Bits 15 - 11: day; 1 - 31; 0 = not available = default; Bits 10 - 6: hour; 0 - 23; 24 = not available = default; Bits 5 - 0: minute; 0 - 59; 60 = not available = default
	number of assisting tugboats	3	0 - 6, 7 = unknown = default
	Air draught	12	0 - 4000 (other values not used), in 1/100m, 0 = default = not used
	Spare	5	Not used. Should be set to zero, reserved for future use
Total	248	occupies 2 slots	

Table 15-5
List of virtual MMSI numbers

V-MMSI	Country
002039991	Austria
n.a.	Belgium
n.a.	Bulgaria
n.a.	Germany
n.a.	Moldova
002268000	France
n.a.	Croatia
n.a.	Hungary
n.a.	The Netherlands
n.a.	Italy
n.a.	Luxembourg
n.a.	Poland
n.a.	Romania
n.a.	Slovak Republic
n.a.	Switzerland
n.a.	Czech Republic
n.a.	Ukraine
n.a.	Russian Federation
n.a.	Serbia

Additional information / usage notes

- a) The message shall be sent by vessels only.
- b) The control status of the message is default on.
- c) The reporting rate should be on event.
- d) The timeout is undefined.
- e) An acknowledgement by the RTA message (Inland ASM FI 22) should be received within 15 minutes. If not, the ETA message should be repeated once. After an additional 15 minutes the user is notified that no answer has been received.

- f) A virtual MMSI number matching the country of the destination addressed by the ETA (see Table 15-5) shall be used for each country. Each national AIS network shall route messages addressed to other countries or different national AIS networks using this virtual MMSI number or based on the ISRS Location Code in the ASM (UN country code, UN location code, fairway section code, Object code and fairway hectometre)
- g) Should no virtual MMSI number be available, the ETA message shall be sent to the closest AIS Base Station
- h) UN country code, UN location code, fairway section code, Object code and fairway hectometre shall be derived from the ISRS Location Code as part of the RIS Index published in the European Reference Data Management System (ERDMS).
- i) The ETA shall always be transmitted in UTC but for input and display converted into local time at the destination.
- j) The air draught shall be the minimum (e.g. with lowered wheelhouse / antenna mast) static air draught at speed = 0.

Optional information content from shore through Application Specific Messages

Inland AIS ASM DAC = 200 FI = 1 (Control Message), DAC = 200 FI = 3 (Inland Capability Interrogation), DAC = 200 FI = 22 (RTA at lock/bridge/terminal), DAC = 200 FI = 25 (Present Bridge Clearance), DAC = 200 FI = 26 (Water level), DAC = 200 FI = 41 (Signal Station), DAC = 200 FI = 42 (Geographic notice) and DAC = 200 FI = 44 (ISRS Text message) are optional messages. If supported they shall be received on the vessel but displayed and handled by an external application, such as Inland ECDIS (see (f), (g), (h), (i), (j), (k), (l) and (m)).

3. Optional Application Specific Messages sent from AIS shore stations

3.1 Control Message (Inland specific message (FI 1))

**Table 15-6
Control Report**

Parameter	Bit	Description	
Message ID	6	Identifier for Message 8; always 8	
Repeat Indicator	2	Used by the repeater to indicate how many times a message has been repeated. Default = 0; 3 = do not repeat any more	
Source ID	30	MMSI number	
Spare	2	Not used, should be set to zero, reserved for future use	
Binary data	Application Identifier	16	DAC = 200, FI = 1
	Version indicator	3	The version number of the message = 1, values 2 to 7 for future use
	UN country code	12	2*6 Bit characters, "00"= unknown; characters 1 and 2 of the ISRS Location Code
	Fairway section code	30	5 x 6 bit characters, "00000"= unknown; characters 6 to 10 of the ISRS Location Code

Parameter	Bit	Description
Fairway kilometre Start	12	Start kilometre of the fairway section where the control message applies bit coded numerical value, 0-4000, 4095 = the whole fairway section, other values not used
Fairway kilometre End	12	End kilometre of the fairway section where the control message applies bit coded numerical value, 0-4000, 4095 = the whole fairway section, other values not used
Application Identifier of controlled ASM	16	DAC and FI of the shipborne ASM to be controlled DAC = 200, FI = XX
Timeout Value	11	Timeout of the Control Message in minutes bit coded numerical value, 0 = forever until disabled message has been received, 1-2047 timeout in minutes, default = 120
Reporting Interval	8	Reporting interval of the controlled ASM in minutes Bit coded numerical value, 0 = default = default value specified for the controlled ASM, 1-255 reporting interval
Enable-Disable	1	0 = Disable message, default 1 = Enable message
Spare	7	Not used. Should be set to zero, reserved for future use
Total	168	Occupies 1 slot

Additional information / usage notes

- a) The message shall be sent from shore only.
- b) The reporting rate should be on event.
- c) The timeout is defined in the message.
- d) The reporting rate depends on the conditions.
- e) Each ASM from a vessel in this inventory has a default "on" or "off" value. This value regulates whether that message shall be broadcast or not prior to the receipt of a relevant Control Message.
- f) The responsibility for initiating/withholding the broadcasting of an ASM from a vessel resides with the external application (e.g. Inland ECDIS). ASMs which are implemented in the Inland AIS station cannot be controlled by this message.
- g) Each Control Message can control one specific ASM (DAC + FI). If more than one ASM has to be controlled, multiple Control Messages are needed.
- h) A Control Message can only control the ASM behaviour for one country, given by the UN country code.
- i) A Control Message can optionally be geographically limited to a specific waterway (fairway section code) or a specific fairway section, defined by start and end waterway-kilometre.

- j) The competent authority has to define the timeout value for the Control Message. By setting the timeout value to 0 the message will never time out. That means the value is stored and will only be changed if a contrary Control Message is received.
- k) The Control message can set or change the reporting rate of the controlled ASM. The reporting rate defined in the Control Message precedes any default setting given in this inventory document.
- l) The Control Message does not apply for responses to the Interrogation on specific IFM (IFM2) and not for responses to the Inland Capability Interrogation (DAC200/FM 3).

3.2 Inland Capability Interrogation to external application (Inland specific message FI 3)

Table 15-7
Inland Capability Interrogation

Parameter	Bit	Description	
Message ID	6	Identifier for Message 6; always 6, ack needed	
Repeat Indicator	2	Used by the repeater to indicate how many times a message has been repeated. See REF#ITU-R1371a, § 4.6.1; 0-3; 0 = default; 3 = do not repeat any more	
Source ID	30	MMSI number of source station	
Sequence number	2	0 – 3; see REF#ITU-R1371a, § 5.3.1.	
Destination MMSI	30	MMSI number of destination Inland AIS station.	
Retransmit flag	1	Retransmit Flag. 0 = no retransmission = default; 1 = retransmitted.	
Spare	1	not used, should be set to zero, reserved for future use	
Binary data	Designated Area Code	10	DAC=200
	Function Identifier	6	FI=3
	Version indicator	3	The version number of the message default = 0, other values for future use
	Requested DAC code	10	DAC (default = 200)
	Spare	67	Not used, should be set to zero, reserved for future use
Total	168	1 slot	

Additional information / usage notes

- a) The message shall be sent from shore only.
- b) The reporting rate should be on event.
- c) The timeout for this message is undefined.

3.3 Requested Time of Arrival (RTA) message (Inland specific message FI 22)

Table 15-8
Requested Time of Arrival

Parameter	Bit	Description	
Message ID	6	Identifier for Message 6; always 6	
Repeat Indicator	2	Used by the repeater to indicate how many times a message has been repeated. Default = 0; 3 = do not repeat any more	
Source ID	30	MMSI number of source station	
Sequence Number	2	0 - 3	
Destination ID	30	MMSI number of destination station	
Retransmit Flag	1	Retransmit Flag should be set upon retransmission: 0 = no retransmission = default; 1 = retransmitted.	
Spare	1	not used, should be set to zero, reserved for future use	
Binary data	Application Identifier	16	DAC = 200, FI = 22
	UN country code	12	2*6 Bit characters, "00"= unknown; characters 1 and 2 of the ISRS Location Code
	UN location code	18	3*6 Bit characters, "000"= unknown; characters 3 to 5 of the ISRS Location Code
	Fairway section code	30	5*6 Bit characters, "00000"= unknown; characters 6 to 10 of the ISRS Location Code
	Object reference code	30	5*6 Bit characters, "00000"= unknown; characters 11 to 15 of the ISRS Location Code
	Fairway hectometre	30	5*6 Bit characters, "00000"= unknown; characters 16 to 20 of the ISRS Location Code
	RTA at lock/bridge/terminal	20	Recommended Time of Arrival; MMDDHHMM UTC Bits 19 - 16: month; 1 - 12; 0 = not available = default; Bits 15 - 11: day; 1 - 31; 0 = not available = default; Bits 10 - 6: hour; 0 - 23; 24 = not available = default; Bits 5 - 0: minute; 0 - 59; 60 = not available = default
	Lock/bridge/terminal status	2	0 = operational 1 = limited operation 2 = out of order 3 = unknown
	spare	2	not used. Should be set to zero, reserved for future use
Total	232	occupies 2 slots	

Additional information / usage notes

- a) The message shall be sent from shore only.
- b) The reporting rate should be on event.
- c) The timeout for this message is undefined.
- d) In response to an ETA message, the RTA shall be sent within 15, maximum 30 minutes after receipt of the initial ETA message.
- e) An RTA message might also be initiated by a shore application alone, e.g. a lock, to notify the vessel for which the message is intended of the requested time of arrival. An optional ETA message may be sent from vessel to shore to confirm the proposed RTA. If the vessel agrees with the RTA, the time of arrival in the ETA answer shall match the RTA. In this case no further confirmation RTA is expected.
- f) UN country code, UN location code, fairway section code, Terminal code and fairway hectometre shall be derived from the ISRS Location Code as part of the RIS Index published in the European Reference Data Management System (ERDMS).
- g) The RTA shall always be transmitted in UTC but for input and display converted into local time at the destination.

3.4 Present Bridge Clearance message (Inland specific message FI 25)

Table 15-9
Present Bridge Clearance message

Parameter	Bit	Description	
Message ID	6	Identifier for Message 8; always 8	
Repeat Indicator	2	Used by the repeater to indicate how many times a message has been repeated. Default = 0; 3 = do not repeat any more	
Source ID	30	MMSI number	
Spare	2	Not used, should be set to zero, reserved for future use	
Binary data	Application Identifier	16	DAC = 200, FI = 25
	Version indicator	3	The version number of the message = 1, values 2 to 7 for future use
	UN country code	12	2*6 Bit characters, "00"= unknown; characters 1 and 2 of the ISRS Location Code
	Fairway section code	30	5 x 6 bit characters, "00000"=unknown; characters 6 to 10 of the ISRS Location Code
	Object reference code	30	5*6 Bit characters, "00000"=unknown; characters 11 to 15 of the ISRS Location Code
	Fairway hectometre	17	Bit coded numerical value 1-99999, 0=unknown, other values not used, derived from character 16 to 20 of the ISRS Location Code
	Bridge Clearance	14	From water surface to lowest point of the bridge in the fairway [in cm] bit coded numerical value 1-9999, 0=unknown, other values not used

Parameter	Bit	Description
Minutes of the day	11	Absolute time of measurement in minutes since UTC midnight 0-1439, 2047=unknown=default, other values not used
Accuracy	5	Bit coded numerical value indicating the accuracy of the bridge clearance 0=unknown, 1-30 = accuracy (+/-) in cm is better than the given value, 31=accuracy worse than +/- 30 cm
Total	178	Occupies 2 slots

Additional information / usage notes

- a) The message shall be sent from shore only.
- b) The reporting rate should be 10 minutes.
- c) The timeout for this message should be 60 minutes.
- d) This message should only be sent by a competent/waterway authority from shore only.
- e) The ISRS Location Code indicates the position of the bridge opening and shall allow the match with the IECDIS display. It consists of UN country code, fairway section code, Object code and fairway hectometre as published in the ISRS Location Code as part of the RIS Index published in the European Reference Data Management System (ERDMS).
- f) The bridge clearance value is the actual measured distance from the water surface to the lowest part of the bridge opening according to the width of the fairway.
- g) The "minutes of the day" provide the absolute time of measurement in minutes since UTC midnight and therefore allow an unambiguous transmission of the age of the data up to 24 hours.
- h) It is recommended that the values transmitted are not older than 1 hour.
- i) If accuracy information is provided it has to be subtracted from the given actual bridge clearance in worst case. It must by no means seen as indication of additional actual bridge clearance.

3.5 Water Level message (Inland specific message FI 26)

Table 15-10
Water Level message

Parameter	Bits	Description
Message ID	6	Identifier for Message 8; always 8
Repeat Indicator	2	Used by the repeater to indicate how many times a message has been repeated. Default = 0; 3 = do not repeat any more
Source ID	30	MMSI number
Spare	2	Not used, should be set to zero. Reserved for future use.
Application Identifier	16	DAC = 200 IF = 26
Version indicator	3	The version number of the message default = 0, other values for future use
UN country code	12	2*6 Bit characters, "00"=unknown; characters 1 and 2 of the ISRS Location Code
Gauge ID 1	11	National unique ID of gauge, "object code" in RIS Index Characters 12 to 15 of the ISRS code. 1-2047, 0 = default = unknown
Water level reference 1	3	0=value of gauge=default, 1=relative to RIS Index reference value 1, 2=relative to RIS Index reference value 2, 3=relative to RIS Index reference value 3; 4=relative to zero point in RIS Index, other values reserved for future use
Water level value 1	17	-65535 to 65535 cm (as per 2's complement), -65536=unknown=default
Gauge ID 2	11	National unique ID of gauge in RIS Index 1-2047, 0 = default = unknown
Water level reference 2	3	0=value of gauge=default, 1=relative to RIS Index reference value 1, 2=relative to RIS Index reference value 2, 3=relative to RIS Index reference value 3; 4=relative to zero point in RIS Index, other values reserved for future use
Water level value 2	17	-65535 to 65535 cm (as per 2's complement), -65536=unknown=default
Gauge ID 3	11	National unique ID of gauge in RIS Index 1-2047, 0 = default = unknown
Water level reference 3	3	0=value of gauge=default, 1=relative to RIS Index reference value 1, 2=relative to RIS Index reference value 2, 3=relative to RIS Index reference value 3; 4=relative to zero point in RIS Index, other values reserved for future use

Parameter	Bits	Description
Water level value 3	17	-65535 to 65535 cm (as per 2's complement), -65536=unknown=default
Spare	4	
Total	168	Occupies 1 slot

Additional information / usage notes

- a) The message shall be sent from shore only.
- b) The reporting rate should be 5-15 minutes.
- c) The timeout for this message should be 18 minutes.
- d) This message should be sent from shore only, to give water level information to all vessels in a certain area. The message should be sent at regular intervals.
- e) The UN country code and the national unique gauge ID shall be derived from the RIS Index of published in the European Reference Data Management System (ERDMS).
- f) The water level data shall only be broadcasted for gauge stations which are included in the European RIS Index.
- g) Consequently the message shall only be displayed on board if it can be successfully linked to the RIS Index gauge object(s).

3.6 Signal Station message (Inland specific message FI 41)

Table 15-11
Signal Station Message

Parameter	Bit	Description	
Message ID	6	Identifier for Message 8; always 8	
Repeat Indicator	2	Used by the repeater to indicate how many times a message has been repeated. Default = 0; 3 = do not repeat any more	
Source ID	30	MMSI number	
Spare	2	Not used, should be set to zero, reserved for future use	
Binary data	Application Identifier	16	DAC = 200, FI = 41
	Version indicator	3	The version number of the message = 1, values 2 to 7 for future use
	UN country code	12	2*6 Bit characters, "00"=unknown; characters 1 and 2 of the ISRS Location Code
	Fairway section code	30	5 x 6 bit characters, "00000"=unknown; characters 6 to 10 of the ISRS Location Code
	Object reference code - type of signal station	3	0-7; 0 = default = unknown, 1 = sistat_8 (Bridge), 2 = sistat_6 (Lock), 3 = sistat_10 (Traffic), 3 = sistat_2 (Port), other values reserved for future use, characters 13 and 14 of the ISRS Location Code

Parameter	Bit	Description
Object reference code - number of signal station	4	0-16; 0-9 = number of signal station, 10 = default = unknown, other values not used, character 15 of the ISRS Location Code
Fairway hectometre	17	Bit coded numerical value 1-99999, 0=unknown, other values not used, derived from character 16 to 20 of the ISRS Location Code
Signal form	4	0-15, 0 = unknown = default, 1-14 signal form according to Figure 15-2
Orientation of signal	9	0-511, 0 – 359 = orientation in degrees, 511 = not available = default, other values not used
Direction of impact	3	1 = upstream, 2 = downstream, 3 = to the left bank, 4 = to the right bank, 0 = unknown = default, other values not used
Light 1 Status	3	Status (1 to 7) of up to 9 lights per signal according to Figure 15-3, 0 = default = unknown, 8-9 not used, 000000000 = default, 777777777 maximum, other values not used
Light 2 Status	3	Status (1 to 7) of light 2 of the signal station. Value 0 = default = unknown/light not relevant for this signal form.
Light 3 Status	3	Status (1 to 7) of light 3 of the signal station. Value 0 = default = unknown/light not relevant for this signal form.
Light 4 Status	3	Status (1 to 7) of light 4 of the signal station. Value 0 = default = unknown/light not relevant for this signal form.
Light 5 Status	3	Status (1 to 7) of light 5 of the signal station. Value 0 = default = unknown/light not relevant for this signal form.
Light 6 Status	3	Status (1 to 7) of light 6 of the signal station. Value 0 = default = unknown/light not relevant for this signal form.
Light 7 Status	3	Status (1 to 7) of light 7 of the signal station. Value 0 = default = unknown/light not relevant for this signal form.
Light 8 Status	3	Status (1 to 7) of light 8 of the signal station. Value 0 = default = unknown/light not relevant for this signal form.
Light 9 Status	3	Status (1 to 7) of light 9 of the signal station. Value 0 = default = unknown/light not relevant for this signal form.
Total	168	occupies 1 slot

Additional information / usage notes

- a) The message shall be sent from shore only
- b) The reporting rate should be 1-2 minutes and on change

- c) The timeout for this message should be 4 minutes
- d) This message should only be sent by a competent authority from shore only. The message should be sent at regular intervals.
- e) The ISRS Location Code indicates the position of the signal on the Inland ECDIS display. It consists of UN country code, fairway section code, Object code and fairway hectometre, and is derived from the RIS Index as published in the ERDMS.
- f) The object code is used in a reduced way. The first two characters of the ISRS Location Code for signal stations, which are always "Si", are not transmitted. The type of the traffic signal station and its number, according to the RIS Index encoding guide, are transmitted separately using the codification given in the table below. The IENC application has to recover the ISRS Location Code and match it with the ISRS Location Code in the Inland ECDIS, taking into consideration that the UN location code is missing.
- g) The light status is coded from left to right from light signal 1 to 9.

Reference tables:

The examples show a grey background in a square of a fixed size of about 3 mm x 3 mm at all display scales with a "post" like it is used for the present static signal in the presentation library. The white point in the centre of the post indicates the position and the post itself allows the user to read the direction of impact. (At a lock, for example, there are often signals for vessels leaving the lock chamber and vessels entering the lock chamber on the inner and the outer side of the door construction) However, the manufacturer of the display software can design the shape of the symbol and the background colour.

The status of a traffic signal can be "No light", "white", "yellow", "green", "red", "white flashing" and "yellow flashing".

For harmonized display an SVG library is provided.

Figure 15-1
Signal forms

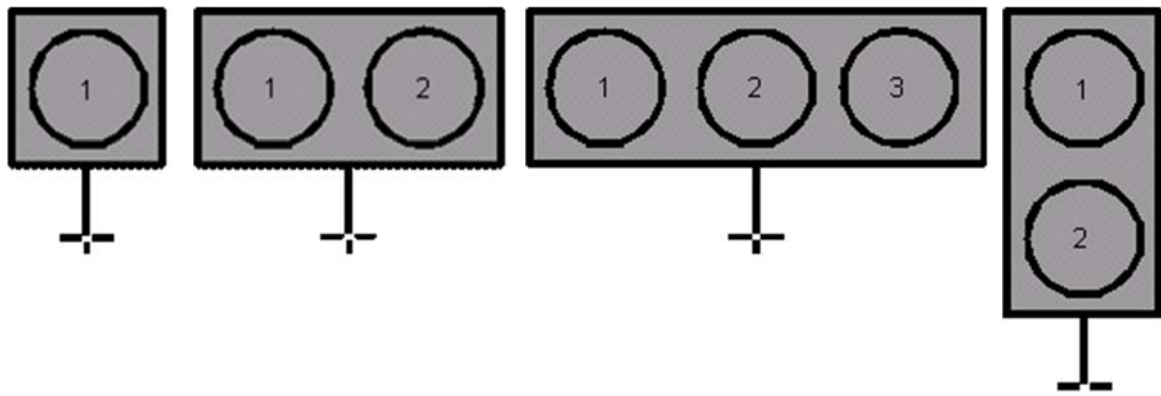

Form 1

Form 2

Form 3

Form 4

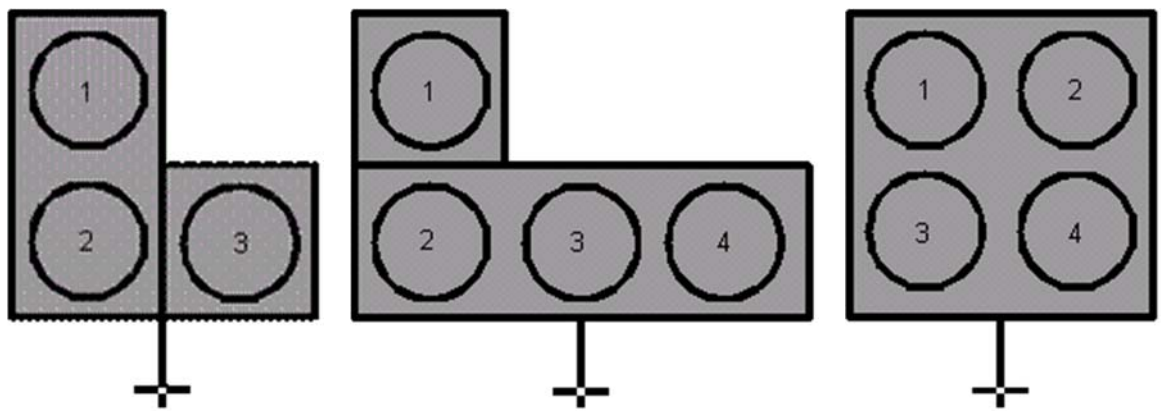

Form 5

Form 6

Form 7

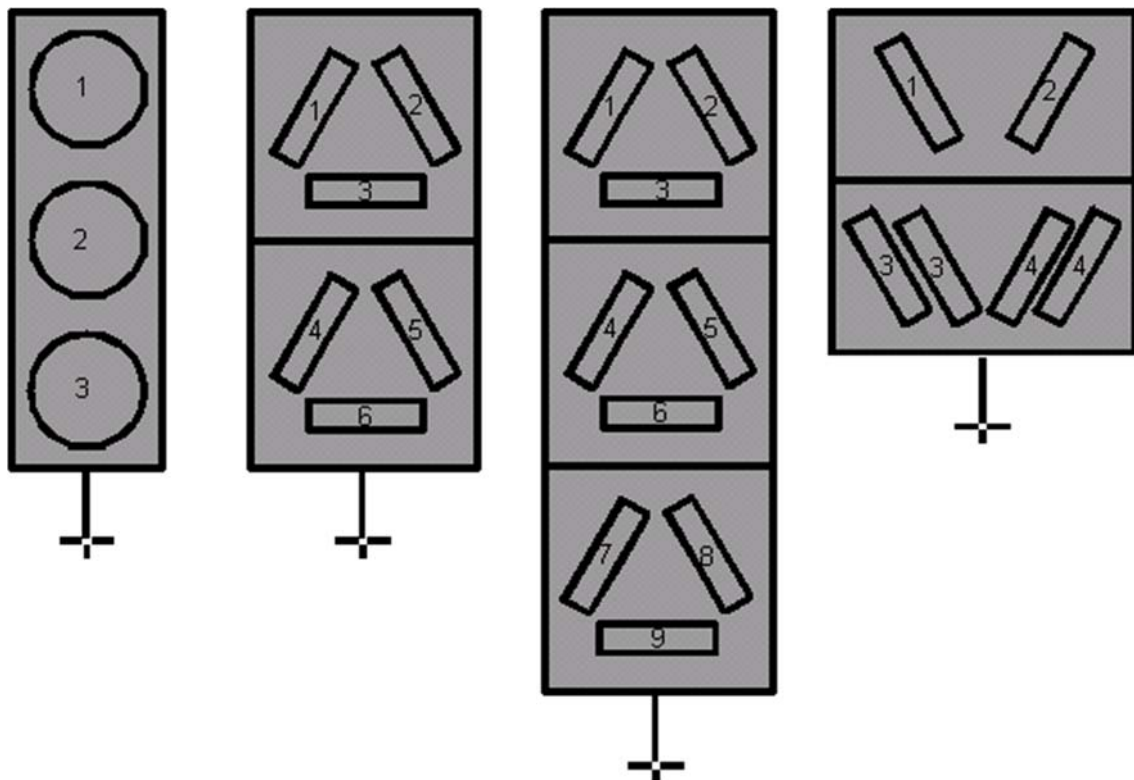

Form 8

Form 9

Form 10

Form 11

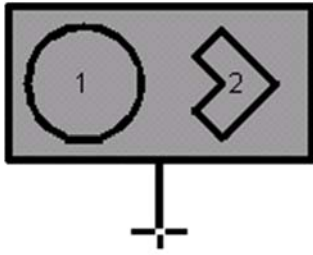

Form 12

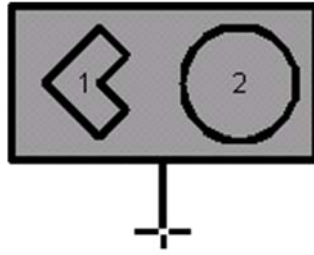

Form 13



Form 14

For each of these signals there are a lot of possible combinations of lights. It is required to use a number to indicate the kind of signal and

a number for each light on a signal to indicate its status

- 1 = no light,
- 2 = white,
- 3 = yellow,
- 4 = green,
- 5 = red,
- 6 = white flashing and
- 7 = yellow flashing.

**Figure 15-2
Light Status**

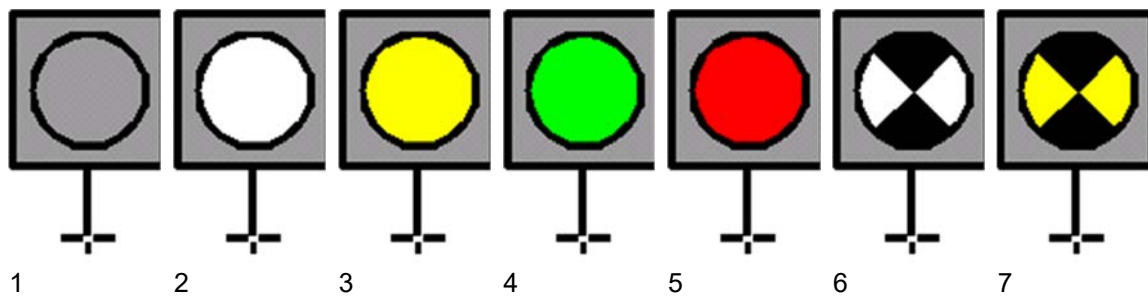

Example: Signal form: 6, light status: 544400000

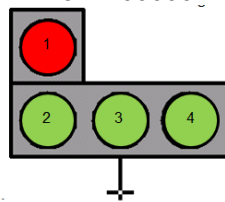

3.7 Geographic Notice (Inland specific message FI 42)

**Table 15-12
Geographic Notice message (Broadcasted Message)**

Parameter		Bit	Description	
Message ID		6	Identifier for Message 8; always 8	
Repeat Indicator		2	Used by the repeater to indicate how many times a message has been repeated. Default = 0; 3 = do not repeat any more	
Source ID		30	MMSI number	
Spare		2	not used, should be set to zero, reserved for future use	
Binary data	Designated Area Code		DAC=200	
	Function Identifier		FI=42	
	Version indicator		3	The version number of the message default = 0, rest for future use
	Spare		3	not used, should be set to zero, reserved for future use
	Message Linkage ID		10	A source specific running number, unique across all binary messages equipped with Message Linkage ID. Used to link additional information to the message by a Text Description message. The Message Linkage ID and the source MMSI uniquely identify the sent message. 1 – 1,023; 0 = not available = default.
	Notice Description		7	Notice Description as per Table 15-21 Set to 0 – 127 according to description. If 127, there must be associated text (see Table 15-20).
	Start time of area	UTC month	4	UTC month of the Area start. 1 – 12; 0 = UTC month not available = default; 13 – 15 (reserved for future use).
		UTC day	5	UTC day of the Area start. 1 – 31; 0 = UTC day not available = default.
		UTC hour	5	UTC hour of the Area start. 0 – 23; 24 = UTC hour not available = default; 25 – 31 (reserved for future use).
		UTC minute	6	UTC minute of the Area start. 0 – 59; 60 = UTC minute not available = default; 61 – 63 (reserved for future use.)
Duration		18	Minutes until end of Geographic Notice, measured from start date and time of Geographic Notice. Maximum duration is 262,142 minutes (182.04 days). 0 = cancel Geographic Notice; 1 – 262,142; 262,143 = undefined = default.	

Parameter	Bit	Description
Action	1	Action parameter: 0 = Advisement; 1 = Directive;
Spare	2	not used, should be set to zero, reserved for future use.
Sub-area 1	96	Area description, structured as in Table 15-16 to Table 15-20 A short text description may be associated with the areas using Sub-area 5: Associated text. 2-slot message.
Sub-area 2	96	optional additional area, structured as in 2-slot message.
Sub-area 3	96	optional additional area, structured as in Table 15-16 to Table 15-20 2-slot message.
Sub-area 4	96	optional additional area, structured as in Table 15-16 to Table 15-20 3-slot message.
Sub-area 5	96	optional additional area, structured as in Table 15-16 to Table 15-20 3-slot message.
Sub-area 6	96	optional additional area, structured as in Table 15-16 to Table 15-20 4-slot message.
Sub-area 7	96	optional additional area, structured as in Table 15-16 to Table 15-20 4-slot message.
Sub-area 8	96	optional additional area, structured as in Table 15-16 to Table 15-20 5-slot message.
Sub-area 9	96	optional additional area, structured as in Table 15-16 to Table 15-20 5-slot message.
Total	216-984	2-5 slot message

**Table 15-13
Geographic Notice message (Addressed Message)**

Parameter		Bit	Description	
Message ID		6	Identifier for Message 6; always 6, ack needed	
Repeat Indicator		2	Used by the repeater to indicate how many times a message has been repeated. (See REF#ITU-R1371a, § 4.6.1). 0-3; 0 = default; 3 = do not repeat any more. Set to 0 (default).	
Source ID		30	MMSI number of source station	
Sequence number		2	0 – 3; see REF#ITU-R1371a, § 5.3.1.	
Destination MMSI		30	MMSI number of destination station.	
Retransmit flag		1	Retransmit Flag. 0 = no retransmission = default; 1 = retransmitted.	
Spare		1	not used, should be set to zero, reserved for future use	
Binary data	Designated Area Code		DAC=200	
	Function Identifier		FI=42	
	Version indicator		3	The version number of the message default = 0, rest for future use
	Spare		3	not used, should be set to zero, reserved for future use
	Message Linkage ID		10	A source specific running number, unique across all binary messages equipped with Message Linkage ID. Used to link additional information to the message by a Text Description message. The Message Linkage ID and the source MMSI uniquely identify the sent message. 1 – 1,023; 0 = not available = default.
	Notice Description		7	Notice Description as per Table 15-21 Set to 0 – 127 according to description. If 127, there must be associated text (see Table 15-20)
	Start time of area	UTC month	4	UTC month of the Area start. 1 – 12; 0 = UTC month not available = default; 13 – 15 (reserved for future use).
		UTC day	5	UTC day of the Area start. 1 – 31; 0 = UTC day not available = default.
		UTC hour	5	UTC hour of the Area start. 0 – 23; 24 = UTC hour not available = default; 25 – 31 (reserved for future use).
		UTC minute	6	UTC minute of the Area start. 0 – 59; 60 = UTC minute not available = default; 61 – 63 (reserved for future use.)

Parameter	Bit	Description
Duration	18	Minutes until end of Geographic Notice, measured from start date and time of Geographic Notice. Maximum duration is 262,142 minutes (182.04 days). 0 = cancel Geographic Notice; 1 – 262,142; 262,143 = undefined = default.
Action	1	Action parameter: 0 = Advisement; 1 = Directive;
Spare	2	not used, should be set to zero, reserved for future use
Sub-area 1	96	Area description, structured as in Table 15-16 to Table 15-20 A short text description may be associated with the areas using Sub-area 5: Associated text. 2-slot message.
Sub-area 2	96	optional additional area, structured as in Table 15-16 to Table 15-20 2-slot message.
Sub-area 3	96	optional additional area, structured as in Table 15-16 to Table 15-20 2-slot message.
Sub-area 4	96	optional additional area, structured as in Table 15-16 to Table 15-20 3-slot message.
Sub-area 5	96	optional additional area, structured as in Table 15-16 to Table 15-20 3-slot message.
Sub-area 6	96	optional additional area, structured as in Table 15-16 to Table 15-20 4-slot message.
Sub-area 7	96	optional additional area, structured as in Table 15-16 to Table 15-20 4-slot message.
Sub-area 8	96	optional additional area, structured as in Table 15-16 to Table 15-20 5-slot message.
Sub-area 9	96	optional additional area, structured as in Table 15-16 to Table 15-20 5-slot message.
Total	248-1016	2-5 slot message

Table 15-14
Number of sub-area transmitted

Number of sub-areas transmitted	1	2	3	4	5	6	7	8	9
Number of bits used for a broadcast message	216	312	408	504	600	696	792	888	984
Number of slots used for a broadcast message	2	2	3	3	3	4	4	5	5
Number of bits used for an addressed message	248	344	440	536	632	728	824	920	1016
Number of slots used for an addressed message	2	2	3	3	4	4	5	5	5

Table 15-15
Sub-areas

Value	Area Shape	Table for Definition
0	Circle or accurate polyline/polygon	Table 15-16
1	Rectangle	Table 15-17
2	Sector	Table 15-18
3	Polyline	Table 15-19
4	Polygon	Table 15-19
5	Associated text	Table 15-20
6-7	Reserved	--

Additional information / usage notes

- a) The message shall be sent from shore only. The reporting rate depends on the conditions.
- b) The timeout for this message should be 3 times the reporting rate, but max. 30 minutes
- c) The information is time-dependent (i.e., has start date/time and duration). If a Geographic Notice (except for a cancellation message – Notice Description 126) is received without a valid start date/time and duration then it should be discarded.
- d) When the current month is December and the notice start month is January, the notice start year shall be the current year plus one; the notice start year shall be the current year in all other cases.
- e) The message may be transmitted prior to the start time/date to allow for advance notice. To avoid confusion, it should not be transmitted more than one day in advance.
- f) The message should not be transmitted beyond the designated end date/time except for a cancellation message. A cancellation message can be transmitted before the designated end date/time using the same Message Linkage ID with a Notice Description of 126 (cancellation), a Duration = 0, and start time fields all set to “not available.”

- g) Presentation software should automatically remove the Geographic Notice from the display after the end date/time or upon receipt of a cancellation message.
- h) Up to 5-slot messages can be created, but messages with more than three slots should be avoided. Messages with more slots are less likely to be received due to RF noise or packet collision.
- i) A circular sub-area (Type 0) with a zero radius (scale factor should also be set to 0) is a point that can be used as a node in a polyline/polygon. This is used when more precision is needed than is possible using the points in the polyline/polygon subarea (the trade-off is more subareas and a longer message). If several points are submitted within one Geographic Notice, the link field shall be used to indicate if the points are related to a polyline(s) or polygon(s).
- j) Polyline/polygon sub-areas (Type 3 or 4) must follow immediately after a circle/point sub-area (Type 0 sub-area with 0 radius) in the same Geographic Notice message. The point defines the start of the line segments. If more than five points are needed for a polyline/polygon, then additional polyline/polygon sub-areas can be used. However, they must follow immediately after the first polygon sub-area and be contained in the same Geographic Notice message.
- k) The polyline/polygon sub-area (Type 3 or 4) should be used to create a polyline/polygon. However, if more precision is needed to specify the points in the polyline/polygon then the circle/point sub-area (Type 0 with radius set to zero) can be used, one sub-area per point. All points (sub-areas of Type 0) must occur in sequence and be contained within the same message. The polyline/polygon is formed by connecting the points.
- l) Polylines could be formed with a mixture of subarea type 0 and type 3 but shall start with subarea type 0. The link indicator shall be 1 whereas the last points/polyline link indicator shall be 0.
- m) Polygon could be formed with a mixture of subarea type 0 and type 4 but shall start with subarea type 0. The link indicator shall be 2 whereas the last points/polyline link indicator shall be 0. The last point (subarea type 0) or last point of the polygon (subarea type 4) shall be connected to the first point of the shape (closing the shape)
- n) Distances and bearings between points in the Geographic Notice should be calculated using Rhumb lines not Great Circles.
- o) The Message Linkage ID and the source MMSI can be used to link additional text (e.g., a separate Linked Text message). This information must be included in both the Geographic Notice and additional Linked Text message.
- p) The total area defined by one Geographic Notice (one Message Linkage ID) is the union of all of the sub-areas contained in the message.
- q) If the same Message Linkage ID and source MMSI are retransmitted with different sub-areas and/or times the presentation software should replace the old Area with the new.
- r) The Message Linkage ID must be unique across all ASMs to which it applies. In this way, the Message Linkage ID and Source MMSI are connected to the same text message.

- s) A message version number is encoded as part of the message; If the received version number is different than what the display system has been programmed for, a message should be displayed to the operator indicating the mismatch in the version.
- t) All directions are relative to True North, all positions are WGS-84 Datum, and all distance calculations should be in accordance with REF#IEC-61993-2 Annex G.

3.7.1 Defining circles and accurate polyline/polygon

Table 15-16
Circle or accurate polyline/polygon

Parameter	Bits	Description
Geographic Notice: Sub-area shape 0	Area Shape	3 Defines the shape of the area. Set to 0 for Circle, or accurate polyline/polygon.
	Scale Factor	2 Scale factor. This is a multiplier for the dimensions of the shape. 1 (default), 10, 100, & 1,000 (scale factor = 10n where n=decimal value of scale factor). 0 = 1x (default), 1 = 10x; 2 = 100x; 3 = 1000x.
	Longitude	28 Longitude of the center in 1/10,000 minute ($\pm 180^\circ$). East = positive, West = negative (as per 2's complement); 181° (6791AC0h) = not available = default.
	Latitude	27 Latitude of the center in 1/10,000 minute ($\pm 90^\circ$). North = positive, South = negative (as per 2's complement); 91° (3412140h) = not available = default.
	Precision	3 Precision of the Lat/Long. Data to be truncated to the number of decimal places specified in this parameter. 0-4 decimal places. Default = 4 (no truncation). 5-6 = Reserved; 7 = Do not use.
	Radius	12 Defines the size of the circular area. This is the radius of the circle in meter increments. 0 = point (default); (scale factor should also be set to 0 in this case) 1 – 4,095 m. This is multiplied by the scale factor to give a maximum size of 4,095 m (4.095 km).
	Link	2 Defines the possible link of the sub message 0 = single point / end point of polygon/polyline (default) 1 = start/additional point of polyline 2 = start/additional point of polygone 3 = unused
	Spare	19 not used, should be set to zero, reserved for future use
Total	96	96 bit subarea

Figure 15-3
Circle diagram

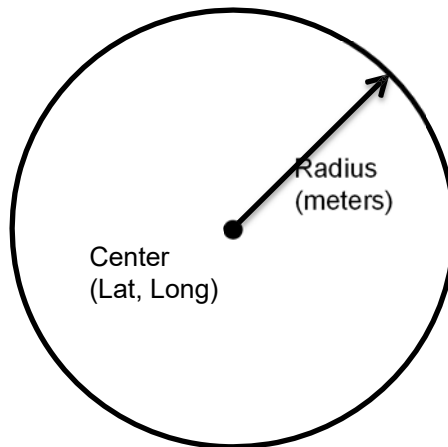

Figure 15-4
Coding of point, polylines and polygons using circle sub-areas

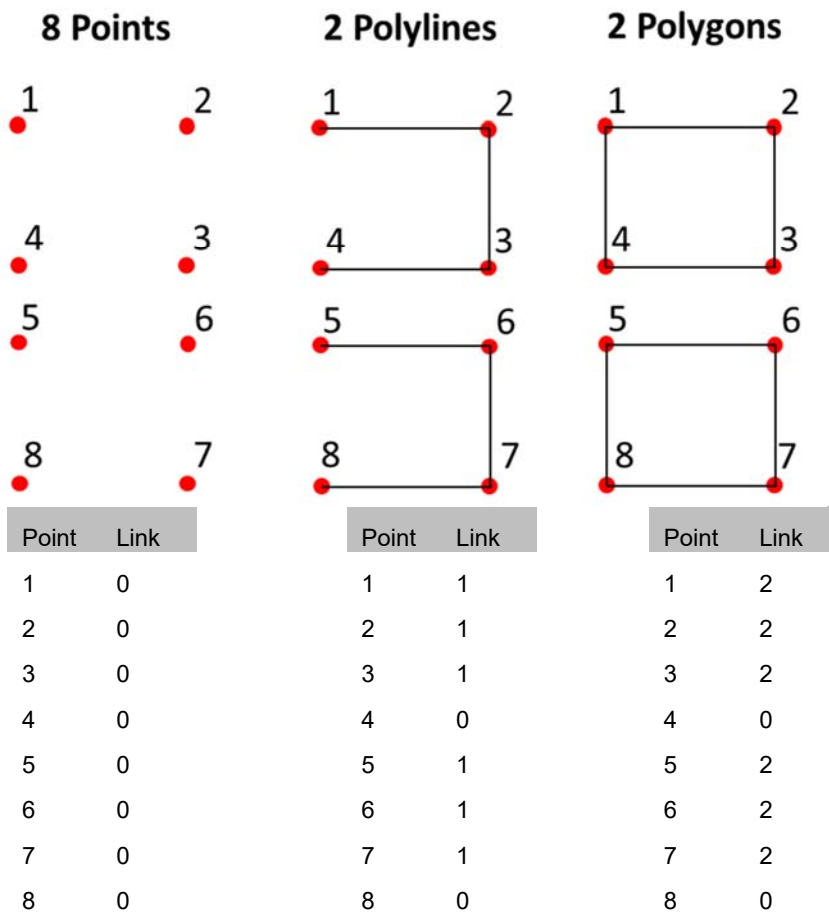
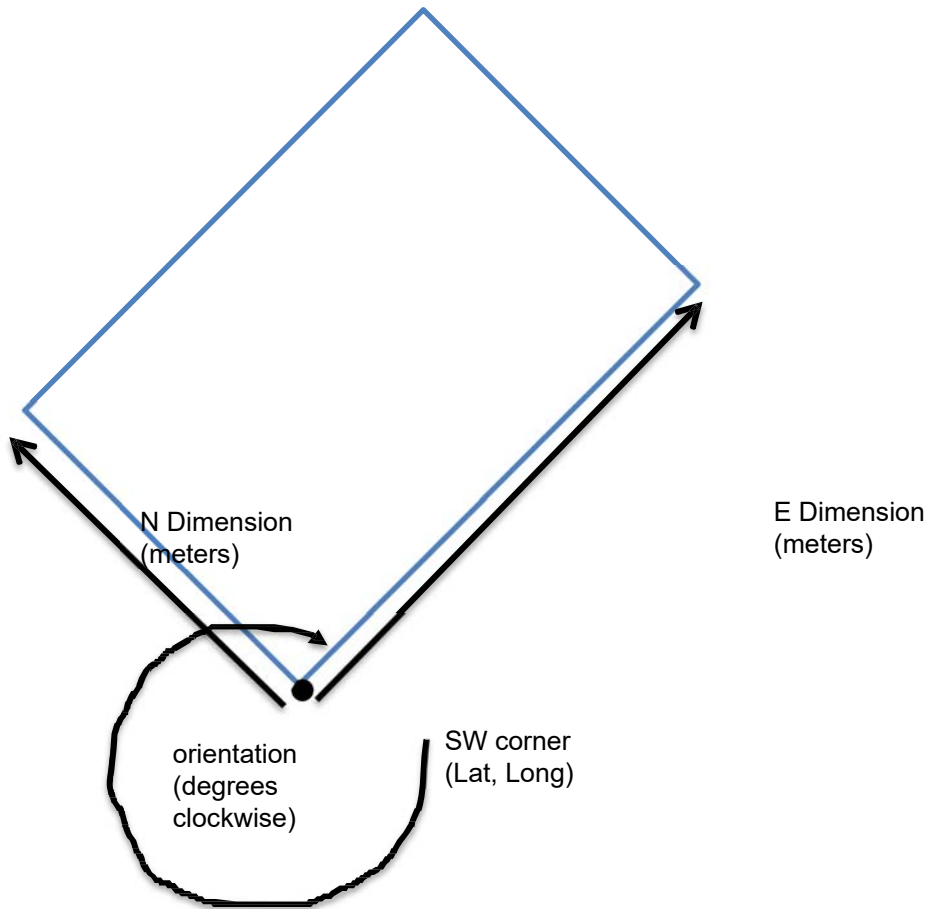

Table 15-17
Rectangle or line or point

	Parameter	Bits	Description
Geographic Notice: Sub-area shape 1	Area Shape	3	Defines the shape of the area. Set to 1 for Rectangle.
	Scale Factor	2	Scale factor. This is a multiplier for the dimensions of the shape. 1 (default), 10, 100, & 1,000 (scale factor = 10n where n=decimal value of scale factor). 0 = 1x (default); 1 = 10x; 2 = 100x; 3 = 1000x.
	Longitude	28	Longitude of the corner point*1 in 1/10,000 minute ($\pm 180^\circ$). East = positive, West = negative (as per 2's complement); 181° (6791AC0h) = not available = default.
	Latitude	27	Latitude of the corner point *1 in 1/10,000 minute ($\pm 90^\circ$). North = positive, South = negative (as per 2's complement); 91° (3412140h) = not available = default.
	Precision	3	Precision of the Lat/Long. Data to be truncated to the number of decimal places specified in this parameter. 0-4 decimal places. Default = 4 (no truncation). 5-6 = Reserved; 7 = Do not use.
	E dimension	8	Box dimension East from the corner point in meter increments. This is multiplied by the scale factor to give a maximum dimension of 255,000m (255 km). 0=line North-South (default); 1 – 255 * scale factor meters.
	N dimension	8	Box dimension North from the corner point in meter steps. This is multiplied by the scale factor to give a maximum dimension of 255,000m (255 km). 0=line East-West (default); 1 - 255 * scale factor meters.
	Orientation	9	Rotation of area in degree steps. Area is rotated clockwise this number of degrees about the position above. 0 = no rotation = default; 1 - 359 = rotation in degrees; 360 – 511 (reserved for future use).
	Spare	8	not used, should be set to zero, reserved for future use
	Total	96	96 bit subarea

**Figure 15-5
Rectangle Diagram**



3.7.2 Defining Sectors

**Table 15-18
Sector**

	Parameter	Bits	Description
Geographic Notice: Sub-area shape 2	Area Shape	3	Defines the shape of the area. Set to 2 for Sector.
	Scale Factor	2	Scale factor. This is a multiplier for the dimensions of the shape. 1 (default), 10, 100, & 1,000 (scale factor = 10 ⁿ where n=decimal value of scale factor). 0 = 1x (default); 1 = 10x; 2 = 100x, 3 = 1000x.
	Longitude	28	Longitude of the center in 1/10,000 minute ($\pm 180^\circ$). East = positive, West = negative (as per 2's complement); 181° = not available = default.
	Latitude	27	Latitude of the center in 1/10,000 minute ($\pm 90^\circ$). North = positive, South = negative (as per 2's complement); 91° = not available = default.

Parameter	Bits	Description
Precision	3	Precision of the Lat/Long. Data to be truncated to the number of decimal places specified in this parameter. 0-4 decimal places. Default = 4 (no truncation). 5-6 = Reserved; 7 = Do not use.
Radius	12	Defines the size of the sector. This is the radius of the sector in meter increments. 1 – 4,095 m. This is multiplied by the scale factor to give a maximum size of 4,095 m (4.095 km).
Left boundary	9	Orientation of the left boundary edge of the sector. This is in degree steps measured clockwise from true North about the center point. 0 = no rotation = default; 1-359 = rotation in degrees; 360-511 (reserved for future use).
Right boundary	9	Orientation of the right boundary edge of the sector. This is in degree steps measured clockwise from true North about the center point. Total sector area is the area measured from the left boundary clockwise to the right boundary. 0 = no rotation = default; 1-359 = rotation in degrees; 360-511 (reserved for future use)
Spare	3	not used, should be set to zero, reserved for future use
Total	96	96 bit subarea

**Figure 15-6
Sector description**

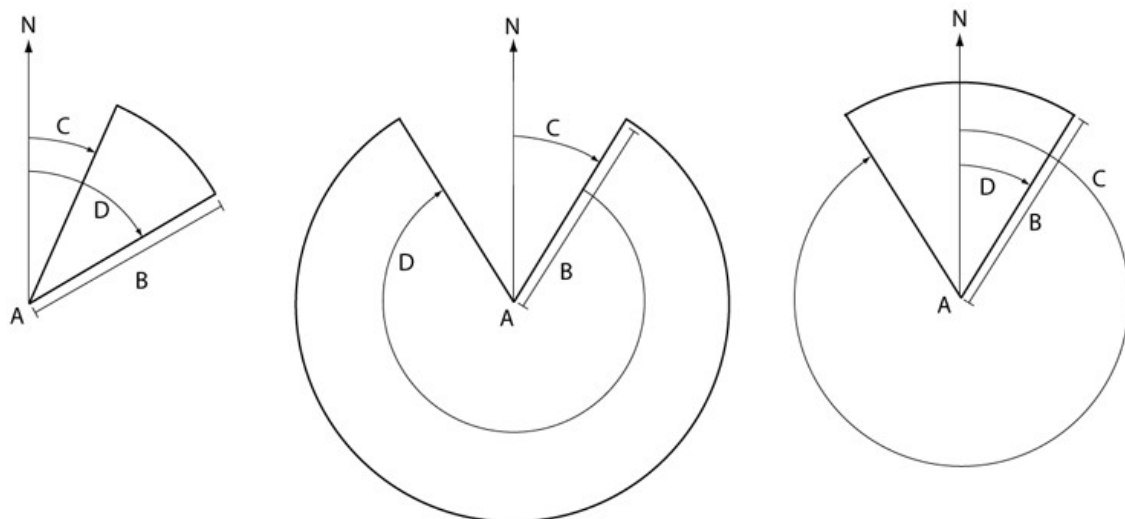

- A) Center point,
- B) Sector radius,
- C) Sector bearings from center point, left boundary,
- D) Sector bearings from center point, right boundary

3.7.3 Defining polylines and (way)points

Table 15-19
Polyline

	Parameter	Bits	Description
Geographic Notice: Sub-area shape 3 (polyline) or 4 (polygon)	Area Shape	3	Defines the shape of the area. Set to 3 for Polyline (open area or line) or set to 4 for Polygon (closed area). The initial point (point 0) is defined by an Area Shape = 0 (Circle, point or accurate polyline/polygon). Or could be added to a previous Polyline/Polygon To close the polygon shape, connect the last defined point back to the initial point (Point 0).
	Scale Factor	2	Scale factor. This is a multiplier for the dimensions of the shape. 1 (default), 10, 100, & 1,000 (scale factor = 10n where n=decimal value of scale factor). 0 = 1x (default); 1 = 10x; 2 = 100x; 3 = 1000x.
	Point 1 Angle	10	True bearing (in half-degree steps) from Point 0 to Point 1 or from the last Point in a Polyline/Polygon directly preceding this Polyline/Polygon to Point 1 in this Polyline/Polygon. Degrees bearing = decimal value (0-719)/2; 720 = not available (no point) = default; 721 – 1,023 (not for use).
	Point 1 distance	11	Distance (in meters) from Point 0 or from the last Point in a Polyline/Polygon directly preceding this Polyline/Polygon to Point 1 in this Polyline/Polygon. Multiply by the scale factor to give a maximum of 2,047 m (2.047 km). 0 = default (no point); 1- 2047 * scale factor meters.
	Point 2 Angle	10	True bearing (in half-degree steps) from Point 1 to Point 2 Degrees bearing = decimal value (0-719)/2; 720 = not available (no point) = default; 721 – 1,023 (not for use).
	Point 2 distance	11	Distance (in meters) from Point 1 to Point 2. Multiply by the scale factor to give a maximum of 2,047m (2,047 km). 0 = default (no point); 1- 2047 * scale factor meters.
	Point 3 Angle	10	True bearing (in half-degree steps) from Point 2 to Point 3 Degrees bearing = decimal value (0-719)/2; 720 = not available (no point) = default; 721 – 1,023 (not for use).
	Point 3 distance	11	Distance (in meters) from Point 2 to Point 3. Multiply by the scale factor to give a maximum of 2,047m (2.047 km). 0 = default (no point); 1- 2047 * scale factor meters.
	Point 4 Angle	10	True bearing (in half-degree steps) from Point 3 to Point 4 Degrees bearing = decimal value (0-719)/2; 720 = not available (no point) = default; 721 – 1,023 (not for use).

Parameter	Bits	Description
Point 4 distance	11	Distance (in meters) from Point 3 to Point 4. Multiply by the scale factor to give a maximum of 2,047m (2.047 km). 0 = default (no point); 1- 2047 * scale factor meters.
Link	2	Defines the possible link of the sub message 0 = single polyline/polygon and/or end point of polygon/polyline (default) 1 = start/additional point of polyline 2 = start/additional point of polygon 3 = unused
Spare	5	not used, should be set to zero, reserved for future use
Total	96	96 bit subarea

Figure 15-7
Example of a single polyline (Area Shape = 3, Link = 0)

Area Notice

Sub-Area: Point (0)
Radius: 0
"Initial Point 0"

Sub-Area: Polyline (3)
Point 1:
Point 1 Angle
Point 1 Distance
Point 2:
Point 2 Angle
Point 2 Distance
Point 3:
Point 3 Angle
Point 3 Distance

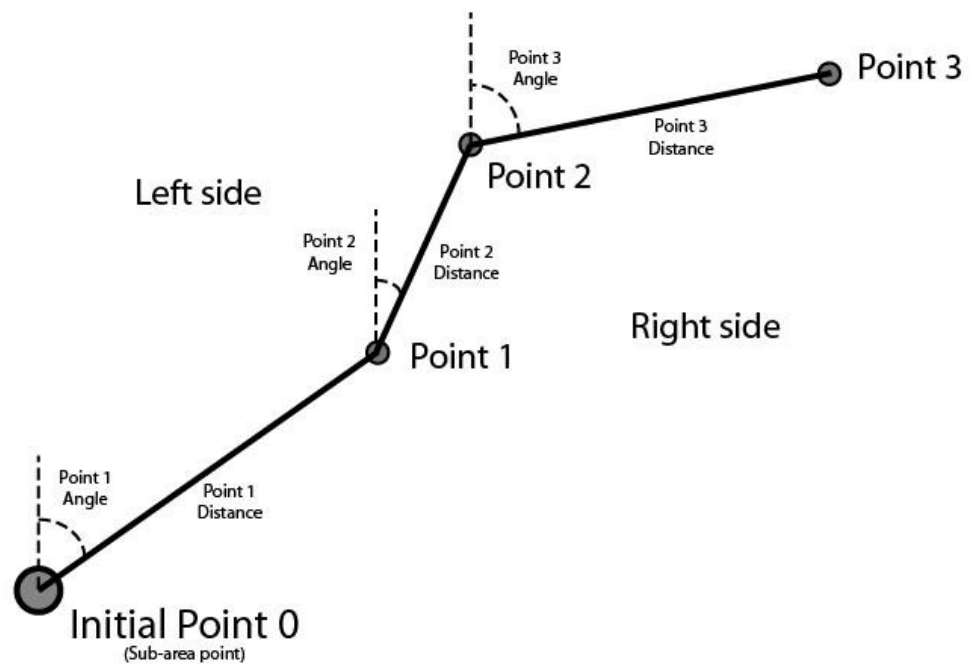

The Figure 15-7 is the graphic description of a waypoint/polyline, showing angle and distance between points. If one side of a polyline is to be a boundary (e.g., edge of ice area), this is defined by the left side of the line in order of sequence from the initial sub-area point (Point 0).

Figure 15-8
Graphic depiction of (1) ice boundary between sea ice and open water,
and (2) recommended route through the sea ice area

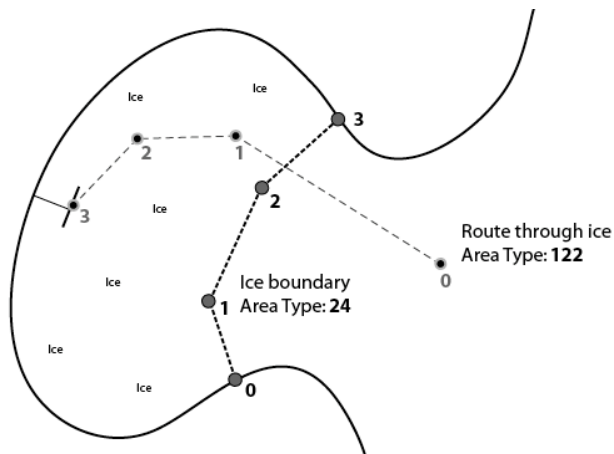
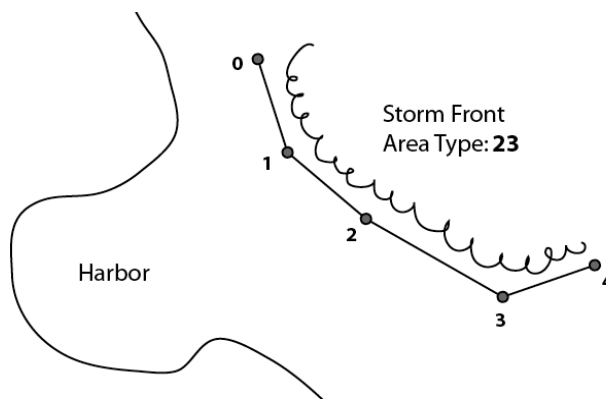

Figure 15-9
A graphic depiction of a storm front message



3.7.4 Associating text to geographical areas

**Table 15-20
Associated Text**

	Parameter	Bits	Description
Geographic Notice: Sub-area	Area Shape	3	Defines the shape of the area. Set to 5 for Associated Text. This text is associated with the area defined in this binary message. Multiple Associated Text sub-areas are glued together in the order they appear in the message.
	Text	90	Fifteen 6-Bit ASCII characters, 6 Bit ASCII characters as per Table 47 in REF#ITU-R1371. If less than 15 characters are required, then the remainder of the field should be filled with "@" characters (set bits to 0). On the IECDIS the @ characters at the end should not be displayed.
	Spare	3	not used, should be set to zero, reserved for future use
	Total	96	96 bit subarea

**Table 15-21
Notice Description**

Value	Description
0	Caution: Marine mammal habitat
1	Caution: Marine mammals in area - reduce speed
2	Caution: Marine mammals in area - stay clear
3	Caution: Marine mammals in area - report sightings
4	Caution: Protected Habitat - reduce speed
5	Caution: Protected habitat - stay clear
6	Caution: Protected habitat - no fishing or anchoring
7	Caution: Derelicts (drifting objects)
8	Caution: Traffic congestion
9	Caution: Marine event or regatta
10	Caution: Divers down
11	Caution: Swim area
12	Caution: Dredge operations
13	Caution: Survey operations
14	Caution: Underwater operation
15	Caution: Seaplane operations
16	Caution: Fishery - nets in water

Value	Description
17	Caution: Cluster of fishing vessels
18	Caution: Fairway closed
19	Caution: Harbor closed
20	Caution: Submerged pipeline or cable
21	Caution: Unmanned vehicle operation
22	Caution: other (define in associated text field)
23	Environmental Caution: Storm front (line squall)
24	Environmental Caution: Hazardous sea ice i.e. icebergs and growlers
25	Environmental Caution: Storm warning (storm cell or line of storms)
26	Environmental Caution: High wind
27	Environmental Caution: High waves
28	Environmental Caution: Restricted visibility (fog, rain, etc)
29	Environmental Caution: Strong currents
30	Environmental Caution: Heavy icing
31	Environmental Caution: Oil or other hazardous substance in area
32	Environmental Caution: other (define in associated text field)
33	Restriction: Fishing prohibited
34	Restriction: Entry approval required prior to transit
35	Restriction: Entry prohibited
36	Restriction: Active military OPAREA
37	Restriction: Firing - danger area
38	Restriction: Drifting mines
39	Restriction: other (define in associated text field)
40	Anchorage: Anchorage open
41	Anchorage: Anchorage closed
42	Anchorage: Anchoring prohibited
43	Anchorage: Deep draft anchorage
44	Anchorage: Shallow draft anchorage
45	Anchorage: Vessel transfer operations
46	Anchorage: other (define in associated text field)

Value	Description
47	Ice Report: Ice Edge
48	Ice Report: New Ice (<10cm ocean < 5 cm lake)
49	Ice Report: Young Ice (10-30cm)
50	Ice Report: Thin 1st year ice (30-70cm ocean, 5-15 cm lake)
51	Ice Report: Medium 1st year ice (70-120cm ocean, 15-30 cm lake)
52	Ice Report: Thick 1st year ice (120-200 cm ocean, 30-70 cm lake)
53	Ice Report: Old /very thick ice (>200cm ocean, > 70 cm lake)
54	Ice Report: Undetermined or unknown thickness
55	Reserved for Future Use
56	Security Alert - Implement USA MARSEC Level 1
57	Security Alert - Implement USA MARSEC Level 2
58	Security Alert - Implement USA MARSEC Level 3
59	Reserved for Future Use
60	Reserved for Future Use
61	Reserved for Future Use
62	Reserved for Future Use
63	Reserved for Future Use
64	Distress: Vessel disabled and adrift
65	Distress: Vessel sinking
66	Distress: Vessel abandoning ship
67	Distress: Vessel requests medical assistance
68	Distress: Vessel flooding
69	Distress: Vessel fire/explosion
70	Distress: Vessel grounding
71	Distress: Vessel collision
72	Distress: Vessel listing/capsizing
73	Distress: Vessel under assault
74	Distress: Person overboard
75	Distress: SAR area
76	Distress: Pollution response area

Value	Description
77	Distress: other (define in associated text field)
78	Reserved for Future Use
79	Reserved for Future Use
80	Instruction: Contact VTS at this point/juncture
81	Instruction: Contact Port Administration at this point/juncture
82	Instruction: Do not proceed beyond this point/juncture
83	Instruction: Await instructions prior to proceeding beyond this point/juncture
84	Instruction: Proceed to this location – await instructions
85	Instruction: Clearance granted – proceed to berth/lock
86	Instruction: other (define in associated text field)
87	Reserved for Future Use
88	Information: Pilot boarding position
89	Information: Icebreaker waiting area
90	Information: Places of refuge
91	Information: Position of icebreakers
92	Information: Location of response units
93	Information: VTS active target
94	Information: Rogue or suspicious vessel
95	Information: Vessel requesting non-distress assistance
96	Information: other (define in associated text field)
97	Chart Feature: Submerged object / sunken vessel (describe in associated text field)
98	Chart Feature: Semi-submerged object
99	Chart Feature: Shoal area
100	Chart Feature: Shoal area due north
101	Chart Feature: Shoal area due east
102	Chart Feature: Shoal area due south
103	Chart Feature: Shoal area due west
104	Chart Feature: Channel obstruction
105	Chart Feature: Reduced vertical clearance
106	Chart Feature: Bridge/Gate/Lock/other closed

Value	Description
107	Chart Feature: Bridge/Gate/Lock/other partially open (opening)
108	Chart Feature: Bridge/Gate/Lock/other fully open
109	Chart Feature: Bridge/Gate/Lock/other partially closed (closing)
110	Chart Feature: Bridge/Gate/Lock/AtoN/other inoperative or not working properly
111	Chart Feature: other (define in associated text field)
112	Report from vessel: Icing info
113	Report from vessel: Intended route
114	Report from vessel: other (define in associated text field)
115	Reserved for Future Use
116	Reserved for Future Use
117	Reserved for Future Use
118	Reserved for Future Use
119	Reserved for Future Use
120	Route: Recommended Route
121	Route: Alternative Route
122	Route: Recommended Route through ice
123	Route: other (define in associated text field)
124	Reserved for Future Use
125	Other – Define in associated text field
126	Cancellation – cancel area as identified by Message Linkage ID
127	Undefined (default)

3.8 ISRS Text message (Inland specific message FI 44)

Table 15-22
ISRS Text message description (Broadcast Message)

Parameter	Bit	Description	
Message ID	6	Identifier for Message 8; always 8	
Repeat Indicator	2	Used by the repeater to indicate how many times a message has been repeated. Default = 0; 3 = do not repeat any more	
Source ID	30	MMSI number	
Spare	2	not used, should be set to zero, reserved for future use	
Binary data	Application Identifier	16	DAC = 200, FI = 44
	Version indicator	3	The version number of the message = 1, values 2 to 7 for future use
	UN country code	12	2*6 Bit characters, "00"= unknown; characters 1 and 2 of the ISRS Location Code
	Fairway section code	30	5 x 6 bit characters, "00000"= unknown; characters 6 to 10 of the ISRS Location Code
	Object reference code	30	5*6 Bit characters, "00000"= unknown; characters 11 to 15 of the ISRS Location Code
	Fairway hectometre	17	bit coded numerical value 1-99999, 0=unknown, other values not used, derived from character 16 to 20 of the ISRS Location Code
	Text	210- 432	35 to 72 x 6-Bit ASCII as defined in REF#ITU-R1371
	Spare	max 7	Not used for data and should be set to zero. Spare bits are needed to maintain byte boundaries. NOTE 1 – When a 6-Bit spare is needed to satisfy the 8-bit byte boundary rule, the 6-Bit spare will be interpreted as a valid 6-Bit character (all zeros is the "@" character).
Total	360-584	Occupies 2 to 3 slots	

Table 15-23
ISRS Text message description (Addressed Message)

Parameter	Bit	Description	
Message ID	6	Identifier for Message 6; always 6	
Repeat Indicator	2	Used by the repeater to indicate how many times a message has been repeated. Default = 0; 3 = do not repeat any more	
Source ID	30	MMSI number	
Sequence Number	2	0 – 3	
Destination ID	30	MMSI number	
Retransmit Flag	1	Retransmit Flag should be set upon retransmission: 0 = no retransmission = default; 1 = retransmitted.	
Spare	1	not used, should be set to zero, reserved for future use	
Binary data	Application Identifier	16	DAC = 200, FI = 44
	Version indicator	3	The version number of the message = 1, values 2 to 7 for future use
	UN country code	12	2*6 Bit characters, "00"=unknown; characters 1 and 2 of the ISRS Location Code
	Fairway section code	30	5 x 6 bit characters, "00000"=unknown; characters 6 to 10 of the ISRS Location Code
	Object reference code	30	5*6 Bit characters, "00000"=unknown; characters 11 to 15 of the ISRS Location Code
	Fairway hectometre	17	bit coded numerical value 1-99999, 0=unknown, other values not used, derived from character 16 to 20 of the ISRS Location Code
	Text	180-402	30 to 67 x 6-bit ASCII as defined in REF#ITU- R1371
Spare	max 7	Not used for data and should be set to zero. Spare bits are needed to maintain byte boundaries. NOTE 1 – When a 6 or 7-Bit spare is needed to satisfy the 8-bit byte boundary rule, the 6-Bit spare will be interpreted as a valid 6 Bit character (all zeros is the "@" character).	
Total	360-584	Occupies 2 to 3 slots	

Additional information / usage notes

- a) The message shall be sent from shore only
- b) The reporting rate should be 6 minutes
- c) The timeout for this message should be 18 minutes
- d) Spare bits shall be used as necessary to maintain byte boundaries.
- e) If an ISRS text message shall be deleted, then the text parameter shall be filled with two @ ASCII characters in a row as the first two characters.
- f) Either the local language where the river is situated or the applicable international language should be used.
- g) The ISRS Location Code indicates the position of the text and shall allow the match with the Inland ECDIS display. It consists of UN country code, fairway sectioncode, Object code and fairway hectometre and is derived from the RIS Index as published in the ERDMS.

Appendix 1 Convoy formation codes (Distributed separately)

***ANNEX 16
(LEFT VOID)***

***ANNEX 17
(LEFT VOID)***

***ANNEX 18
(LEFT VOID)***

European Committee for drawing up Standards in the field of Inland Navigation
(CESNI)

Edition 2025/1

**EUROPEAN STANDARD FOR RIVER INFORMATION SERVICES
ANNEXES**

Annexes 19 to 27

ANNEX 19

ELECTRONIC REPORTING DATA DEFINITIONS

TABLE OF CONTENTS

1.	INTRODUCTION	525
2.	DATA DESCRIPTIONS	525
2.1	Primitive data types.....	525
2.1.1	Boolean (BOOL)	525
2.1.2	Integers (POSINT)	526
2.1.3	Decimal floating point (FLOAT)	526
2.1.4	Text fields (TEXT).....	526
2.1.5	Date and Time (DATE, TIME, DATETIME)	527
2.2	Single-value data types	527
2.2.1	Dimensions (DIM_C and DIM_H)	528
2.2.2	Volume (VOLM)	528
2.2.3	Weight (WEIGHT_K and WEIGHT_T).....	528
2.2.4	Power (POW_KW).....	528
2.2.5	Country or nationality (CNTRY_2 and CNTRY_3)	529
2.2.6	UNECE location code (UNLC).....	529
2.2.7	Fairway section code (FWSEC).....	529
2.2.8	Forward to Authority (FWDAUTH).....	529
2.2.9	Message identifier (IDMESS)	530
2.2.10	Test Scenario (SCENAR)	530
2.2.11	Universally Unique Identifier (UUID).....	530
2.3	Multiple-value data types	530
2.3.1	Message Type (MESSTYP).....	531
2.3.2	Message Information (MESSINFO).....	532
2.3.3	Location (LOCID).....	533
2.3.4	Vessel Type (VESSID)	533
2.3.5	Dimensions of Transport (TDIM)	534
2.3.6	Details of Transport (TDET).....	534
2.3.6.1	Transport information (TINFO)	535
2.3.6.2	Transport Reference (TREF).....	536
2.3.6.3	Transport Locations (TLOC).....	536
2.3.6.4	Route Waypoint (WPT).....	536
2.3.7	Party Identification, Name and Address (PARTYID)	537
2.3.8	Contact Party (CONTPARTY)	538
2.3.8.1	Contact Information (CONTINFO).....	538
2.3.8.2	Contact Information details (CONTDDET).....	538
2.3.9	Barge Information (BARGINFO).....	539
2.3.9.1	Power installations on board (POWBY)	539
2.3.10	Container totals (CONTAINTOT).....	540
2.3.11	Consignment (CONSI).....	540
2.3.11.1	Goods Item (GOIT).....	541
2.3.11.2	Non-dangerous goods information (NDGINFO).....	542
2.3.11.3	Dangerous goods Information (DGINFO).....	543
2.3.11.4	Dangerous goods (DGOODS).....	544
2.3.11.5	Hazard Placard (HAZ)	545
2.3.11.6	Good Stowage location information (STOWINFO).....	545
2.3.11.7	Stowage Vessel (STOWV)	546
2.3.11.8	Additional goods information (ADDINFO)	546
2.3.11.9	Distribution of the Cargo (DISTCARGO).....	547

1. Introduction

This annex defines data types to be used in the specification of electronic reporting message types. It aims to define data types that are not specific for a message type but that can be used or could be used in several electronic reporting message types. Data types that are specific to an electronic reporting message type are defined in the annex relating to this message type.

Together with the definition of data types, a set of rules may be given for each data type that will be valid whenever this data type is used.

The data types are defined independently from a format (for example XML). The possible formats for a message type and the specific requirements relative to each possible format are provided in the annex relating to this message type.

2. Data Descriptions

2.1 Primitive data types

Primitive data types are a set of basic data types from which all other data types are constructed. Although the implementation of these primitive data types may vary from one system to another (byte encoding, precision etc.), they are described here in a generic and abstract way. However, these primitive data types shall be implemented consistently in all (more advanced) data types using them and in all ERI message types. For example, a date should always be provided in the same way in all fields representing a date.

The primitive data types are generic, with no particular meaning.

For better clarity, the primitive data types are listed by category. A category may contain one or several primitive data type. Each primitive data type is designated by a code, which will be used as a reference by other data types using this primitive data type.

2.1.1 Boolean (BOOL)

This primitive data type has one of two possible values: true and false. Depending on the implementation, it can be zero/one, true/false etc.

Code	Description
BOOL	Can be either true or false.

In a context when this data type is used as an optional field, unless otherwise specified, the absence of this field shall be considered equivalent to the value "False".

2.1.2 Integers (POSINT)

This primitive data type category represents integers.

Code	Description
POSINT	Positive Integers, ranging from 0 until a maximum integer which is indicated when this data type is used.

Notes:

- Range can vary for this data type.
- The Maximum is indicated in parenthesis after the code of the data type.
- Example: POSINT (99)

2.1.3 Decimal floating point (FLOAT)

This data type represents a floating-point number. Each format may have different implementation for floating-point numbers. As a guideline, the principle of REF#/IEEE-2008754 should be preferred over other alternatives. Floating-point numbers should be encoded with an indication of the sign (positive or negative) and using 32 or 64 bits.

Code	Description
FLOAT	A floating point number.

2.1.4 Text fields (TEXT)

This primitive data type category corresponds to a string of limited length. It can be used in a wide variety of situation, for example when free text is required.

Each primitive data type in this category is bound to a certain set of characters available (the "charset"). Only characters included in the charset may be used in the string. However, the length of the string can be given independently from the primitive data type.

Code	Description
TXT	A string, with a charset: <ul style="list-style-type: none"> - 26 upper case latin letters: [A-Z] - 26 lower case latin letters: [a-z] - 10 digits: [0-9] - 20 special characters: . , - () / = (space) ' + : ? ! " % & * ; < >
TXT_UP	Same as TXT but lower case characters [a-z] are excluded

Notes:

- Maximum length of the string is mandatory and indicated in parenthesis after the code of the data type
 - Example: TXT (32).
- Minimum length of the string is optional and can be specified as a first number before the maximum length, separated by a hyphen.
 - Example: TXT (5-32).

2.1.5 Date and Time (DATE, TIME, DATETIME)

This primitive data type category is used to define a date or a time (or both).

These primitive data types are highly system-dependent, ranging from simple strings to floating numbers representing the number of seconds since a reference date. As a principle, a representation of the date and/or time following REF#ISO-8601 should be preferred over other alternatives.

Code	(indicative) format	Description
DATETIME	YYYY-MM-ddTHH:mmZ	A representation of a date. The date shall include the years in full (4 digits). Unless otherwise specified, the precision of time shall be the minute. Hours and minutes are given with always two digits each (adding a leading "0" when values are smaller than 10). Hours are given in 24 hours format, from 00 to 23.

Notes:

- The format in the table above is only indicative. It is based on the most current use of REF#ISO-8601. In the REF#ISO-8601, the letter "T" is used to separate the date and the time and the letter "Z" in the end indicates the UTC time zone.
- The time zone shall be indicated.

2.2 Single-value data types

The single-value data types are data types that contain only one field. They are different from primitive data types because they are meaningful and can only be used in a certain context. However, they refer directly (and only) to primitive data types for implementation purposes.

2.2.1 Dimensions (DIM_C and DIM_H)

These data types are used whenever a dimension is required. This can be a length, a width, a draught or a height. This can be also a distance. These data types are always represented by positive integers. A dimension measures the distance between two points (or objects) but without indication of origin and destination, thus always positive.

Code	Unit	Primitive data-type	Description
DIM_C	cm	POSINT(99999)	Is used for precise measurements (of a vessel or a convoy for example).
DIM_H	hm	POSINT(99999)	Is used to measure distance along the fairway.

2.2.2 Volume (VOLM)

This data type is used whenever a volume is required. It can be the volume of a container. This data is a positive integer.

Code	Unit	Primitive data-type	Description
VOLM	m ³	POSINT(999999999)	Volume is always given in cubic meter.

2.2.3 Weight (WEIGHT_K and WEIGHT_T)

This data type is used whenever a weight, or a weight capacity is required. It can be the weight of a cargo, the capacity or the dead weight of a vessel or of a container (ie: the maximum weight that can be carried). This data is a positive integer.

Code	Unit	Primitive data-type	Description
WEIGHT_K	kg	POSINT(999999999)	Weight in kilograms
WEIGHT_T	t	POSINT(999999)	Weight in metric tons

2.2.4 Power (POW_KW)

This data type is used whenever a power is required. The power is the amount of energy transferred or converted per unit time.

Code	Unit	Primitive data-type	Description
POW_KW	kW	POSINT(999999)	Power in kilo Watt

2.2.5 Country or nationality (CNTRY_2 and CNTRY_3)

This data type is used whenever a country, or a nationality is required. This data type is a string with all letters in capital.

Code	Unit	Primitive data-type	Description
CNTRY_2	n.a.	TXT_UP(2)	2 letter country code
CNTRY_3	n.a.	TXT_UP(3)	3 letter country code

Note:

- The country codes used shall comply with REF#ISO-3166-1 (alpha-2 or alpha-3).

2.2.6 UNECE location code (UNLC)

This data type is used whenever a location code is required. A location code is represented by a string with all letters in capital and digits, following the codification of UNECE (REF#UNECE-R16 revision 4), see also in Part IV, Article 2.03(9).

Code	Unit	Primitive data-type	Description
UNLC	n.a.	TXT_UP (5)	A location code. See Part IV, Article 2.03(9).

2.2.7 Fairway section code (FWSEC)

This data type is used when a section of a fairway is required. It uses a codification made of letters and digits.

Code	Unit	Primitive data-type	Description
FWSEC	n.a.	TXT_UP (5)	A fairway section code. See Part IV, Article 2.03(10).

2.2.8 Forward to Authority (FWDAUTH)

This data type is used to indicate if a message is allowed to be forwarded to other authorities (than the receiving authority).

Code	Unit	Primitive data-type	Description
FWDAUTH	n.a.	BOOL	This boolean can be used to indicate if the message can be forwarded to other authorities.

2.2.9 Message identifier (IDMESS)

The message identifier is used to relate messages with each other. When a message identifier is created, it should be as unique as possible, both for sender and for receiver. If a message is received and then passed on to another receiver, the original message identifier shall be used. The transitional system shall in this case not generate another message identifier.

Code	Unit	Primitive data-type	Description
IDMESS	n.a	TXT (35)	This is a (unique) identifier for a message.

2.2.10 Test Scenario (SCENAR)

This field can be used to refer to a test scenario. It is used for testing purposes and both the sender, and the receiver should share the test scenario reference in advance.

Code	Unit	Primitive data-type	Description
SCENAR	n.a.	TXT (35)	Reference to a test scenario, which shall be known at the receiving party.

2.2.11 Universally Unique Identifier (UUID)

A UUID is a standardized identifier documented in the ITU-T Recommendation X.667 (or ISO/IEC 9834-8 : 2014 or IETF RFC 4122, all these references having identical content). The UUID format allows 5 methods (called versions) to generate identifiers that are unique across all devices and systems. The 5 methods generate a 128-bit value and they are compatible with each other. The canonical representation consists of a sequence of 36 alphanumeric characters (32 hexadecimal digits and 4 dashes), such as "0b2e113e-a27f-4f8f-b998-cf94b5bee34b".

Code	Unit	Primitive data-type	Description
UUID	n.a.	TXT (36)	Universally unique identifier

2.3 Multiple-value data types

Multiple-value data types are composed of several values (or components). Each component can be either a primitive data-type, a single-value data type or another component.

For the sake of clarity, the components that are used as sub-components of only one (main) component are indicated below the main component.

Only multiple-value data types that may be used in several electronic reporting message types are defined here. The multiple-value data types specific to a given electronic reporting message type are defined in the corresponding annex. Sometimes, generic data types are slightly modified or adapted for some message types. In this case, they will be redefined in the corresponding annex, using the same name.

For each data type, the last column indicates the number of occurrences for a component.

- A fixed number means it is expected to find exactly this number of occurrence(s)
- A range of occurrence means there is a minimum and maximum number of occurrence(s).
- A minimum occurrence of zero means the component is optional and may be absent.

2.3.1 Message Type (MESSTYP)

The Message Type data type aims to indicate the Electronic Reporting Message Type, including the version of the message.

Components	Description	Type of data	Nb
Controlling Agency	International organisation responsible for maintenance of the original message structure (UN/EDIFACT)	TXT_UP (2)	1
Controlling Agency (Level A)	Department of the international organisation responsible for maintenance of the original message structure (UN/EDIFACT).	TXT_UP (4)	1
Syntax Version	The version number of the syntax used in the original message structure (UN/EDIFACT).	POSINT(9)	1
Message Type	The message type (looking at the content)	TXT_UP (6)	1
Message Version	The version number of this message type.	TXT_UP (3)	1
Message Release	The release number of this message version.	TXT_UP (3)	1
Assigned Code	A code used to designate this message in a single string	TXT_UP (6)	1

Note: Some values inside of this data type are designed to provide legacy support with historical message structure such as 'IFTDGN'¹ or 'APERAK'². The original structure of the Electronic Reporting Messages was using UN/EDIFACT format and were maintained by the United Nations. Thus, the information eventually filled in should be interpreted in this context.

¹ IFTDGN: International Forwarding and Transport Dangerous Goods Notification

² APERAK: APplication ERror and AcKnowledgegement message

2.3.2 Message Information (MESSINFO)

The Message Information data type aims in providing postal-like information to send and deliver the message to the correct recipient in an electronic format.

Components	Description	Type of data	Nb
Sender ID	Identification of the sender of the message. This may be a mailbox, a unique name or the unique identifier of a RIS-centre or traffic post.	TXT (25)	1
Recipient ID	Identification of the recipient of the message. This may be a mailbox, a unique name or the unique identifier of a RIS-centre or traffic post.	TXT (25)	1
Date and Time of the message	Date and Time when the message was generated	DATETIME	1
Acknowledgement request	Indicates whether the sender requests an acknowledgement	BOOL	0-1
Test Indicator	Indicates whether the interchange relates to a test message	BOOL	0-1
Message Subtype	Indicate the (sub) type of message	TXT_UP (3-3)	1
Message identifier	Unique identifier for this message. A new identifier shall be created for each message. This identifier may be used by other messages to relate with the current message.	IDMESS	1
Function of message	Describes the purpose of the message (new message, update, cancel etc.)	POSINT (999)	1
Common Denominator	This field can be used to relate several messages of same journey (Common Access Reference). When it is used, it should be as unique as possible to avoid relating messages improperly.	TXT (35)	0-1

Note: The Message Type in MESSINFO is not the same information as the Message Type in MESSTYP. The first can be considered as a subtype of the second.

Instruction to fill data:

- "Acknowledgement Request" and "Test Indicator" are both optional fields.

2.3.3 Location (LOCID)

The Location data type aims to define a location using several components such as its UN/ECE code, and its name. It is used to identify the locations on the vessel's route.

Components	Description	Type of data	Nb
Location code	UN/ECE location code of this location (identifier)	UNLC	1
RIS ID	Identifier of the location in RIS.net	UUID	0-1
Location Name	Full name of the location	TXT(70)	0-1
Terminal Code	UN/ECE location code of the passage point. see Part IV, Article 2.03(11).	UNLC	0-1
Terminal Name	Full name of the terminal	TXT(70)	0-1
Fairway Section Code	The section of the fairway where the location is	FWSEC	0-1
Fairway Hectometre	The hectometre at the centre of the area '00000' means that information is not available	DIM_H	0-1

2.3.4 Vessel Type (VESSID)

The Vessel Type data type provides the IMO or ENI number of a vessel, when available.

Components	Description	Type of data	Nb
Vessel Number	IMO or ENI identification number	TXT(7-8)	1
ID code	Indicates the type of identification number	TXT_UP(3-3)	1
MMSI	Maritime Mobile Service Identity	POSINT(99999999 99)	0-1

Instruction to fill data:

- The Vessel Number shall be 7 digits for IMO indication or 8 digits for unique European vessel identification number (ENI).
- The three letters composing the ID code shall be:
 - 'IMO' for an IMO-number, see Part IV, Article 2.03(2);
 - 'ENI' for a unique European vessel identification number, see Part IV, Article 2.03(3).

2.3.5 Dimensions of Transport (TDIM)

The Dimensions of Transport data type provides the total dimensions of a vessel or a convoy.

Components	Description	Type of data	Nb
Total Length	Total length of the convoy	DIM_C	1
Total Width	Total width of the convoy	DIM_C	1
Draught	Draught of the convoy	DIM_C	1
Maximum Capacity	Maximum capacity of the convoy	WEIGHT_T	1
Height Above the Waterline	Height above the waterline of the transport	DIM_C	0-1

Instruction to fill data:

- If due to legal restriction the Draught of the convoy cannot be submitted, the value of this field shall be '9999'.

2.3.6 Details of Transport (TDET)

The Details of Transport data type provides general and detailed information on the vessel or convoy, including the identification and type of the main vessel, the dimension of the convoy and the planned route.

Components	Type of data	Nb
Transport detail information	TINFO	1
Convoy's Dimensions	TDIM	1
Reference	TREF	0-3
Itinerary	TLOC	1

Note:

- A single vessel without barge is also a convoy in this context.

2.3.6.1 Transport information (TINFO)

The Transport Information data type is used by TDET component and provides details about the vessel and mode of transport.

Components	Description	Type of data	Nb
Voyage number	Voyage number as defined by the sender	TXT(17)	0-1
Mode of Transport	Inland water transport or maritime transport	TXT(1)	1
Means of Transport	Code for ship and convoy types of means of transport from UN/CEFACT	TXT(4)	1
Vessel	Specifications of the vessel (number and type of id)	VESSID	1
Vessel's Name	Name of the vessel	TXT(35)	1
Vessel's Nationality	Registration Country of the vessel	CNTRY_2	0-1
Stage Qualifier	Transport stage code qualifier	TXT(35)	1
Previous Vessel name	Previous name of the vessel (if applicable)	TXT(35)	0-1
Previous Vessel nationality	Previous registration country of the vessel (if applicable)	CNTRY_2	0-1

Instruction to fill data:

- The Mode of Transport shall be:
 - '8' for Inland water transport;
 - '1' for maritime transport.
- The Means of Transport shall refer to the code for ship and convoy types of means of transport, see Part IV, Article 2.03(1).
- If the Vessel's Name is more than 35 characters, the name of the vessel is shortened.
- If the nationality of the means of transport is not known, the 3-digit code of the country of the inspection body that issued the last vessel certificate shall be used.
- The Stage Qualifier shall be '20' for main carriage transport.

2.3.6.2 Transport Reference (TREF)

The Transport Reference data type is used by TDET component and provides the reference number of the transport document.

Components	Description	Type of data	Nb
Ref Qualifier	Reference of Qualifier	TXT(3-3)	1
Ref No	Reference number of the transport document	TXT(35)	1

2.3.6.3 Transport Locations (TLOC)

The Transport Locations data type is used by TDET component and provides the vessel's locations from the port of departure to the port of destination. A time of passage can be attributed to each location on the way.

Components	Description	Type of data	Nb
Port of Departure	The port where the transport starts	LOCID	1
Passage Point	Passage point that has most recently been passed by the vessel	LOCID	0-1
Next Passage Point	Next passage point that will be passed by the vessel	LOCID	0-1
Future Passage Points	Intermediate points on the route	WPT	0-5
Port of Destination	This is the first port where the transport is bound.	LOCID	1
ETD	Estimated Time of Departure	DATETIME	0-1
Passage Time	Passage time, as recorded by the traffic centre	DATETIME	0-1
ETA	Estimated Time of Arrival	DATETIME	0-1

Instruction to fill data:

- The Future Passage Points shall be sorted in the order of passage (with the earliest Route Point Passage Time first).
- The ETA shall be later than the ETD for a voyage.
- The ETD shall be later than the ETA for a visit.

2.3.6.4 Route Waypoint (WPT)

The Route Waypoint data type is used in TLOC. It is composed of a Location and a time of passage. It can be used to describe one point in the vessel's itinerary (achieved or planned).

Components	Description	Type of data	Nb
Route Point	Location on the route of the vessel	LOCID	1
Route Point Passage Time	Time and date of passage in the location	DATETIME	0-1

Instruction to fill data:

- Route Point Passage Time shall correspond to the (estimated) time and date of passage at the location.

2.3.7 Party Identification, Name and Address (PARTYID)

The Party Identification, Name and Address data type provides information on a party, including its role, name, postal address and identification.

Components	Description	Type of data	Nb
Party qualifier	Party function code qualifier	TXT(2)	1
Identification code	EAN number of the party	TXT(35)	0-1
Name	Name of the Party	TXT(35)	1
Street	Name of the Street	TXT(35)	1
City	Name of the City	TXT(35)	0-1
Postal Code		TXT(9)	0-1
Country	Country code	TXT(2-3)	0-1
Reference number	Invoice, VAT or Admin reference number	TXT(35)	0-1

Instruction to fill data:

- The Party qualifier can take the following values:
 - 'MS' for message sender;
 - 'MR' for message receiver;
 - 'CG' for agent/invoice address (for VNF this information is mandatory);
 - 'SF' for sender address (cargo);
 - 'CPE' Boatmaster;
 - 'AM' Authorised official (security officer);
 - 'ST' for destination address (cargo).
- The Identification code is mandatory for notifications to the Port of Rotterdam. Port of Rotterdam. ERI fills this element with '900000000'.

2.3.8 Contact Party (CONTPARTY)

The Contact Party data type identifies a party and provides information to contact it.

Components	Description	Type of data	Nb
Name and Address	Name and address of message sender	PARTYID	1
Contact information	Information needed to contact a party	CONTINFO	0-1

2.3.8.1 Contact Information (CONTINFO)

The Contact information data type is used by CONTPARTY and is used to group contact information for a party.

Components	Description	Type of data	Nb
Job position of the contact	This field is present for legacy purposes and shall be filled with the dummy value 'ERI'	TXT(3)	0-1
Contact details	Communication contact details	CONTDDET	0-4

2.3.8.2 Contact Information details (CONTDDET)

The Contact Information details data types is used by CONTPARTY/CONTINFO and provides the various means to contact a party.

Components	Description	Type of data	Nb
Communication contact	Communication number or E-mail address	TXT(70)	1
Type of communication	Means used for communication which can be: - 'TE' for telephone number; - 'FX' for fax number; - 'EM' for email address; - 'EI' for EDI mailbox.	TXT(2)	1

2.3.9 Barge Information (BARGINFO)

The Barge information data type contains information on a single barge. A convoy is composed of several barges.

Components	Description	Type of data	Nb
Barge ID	Identification number of the barge	VESSID	1
Code	Code for ship and convoy types of means of transport	TXT(4)	1
Name	Name of the barge	TXT(35)	1
Propulsion participation	Indicate if the barge participates in the propulsion	TXT(3)	1
Dimensions	Dimensions of the individual barge	TDIM	1
Total Power	Total power (in kW) of the propulsion system (corresponding to item 28 of the REF#CESNI-ESTRIN-3a)	POW_KW	0-1
Alternative fuel system Indicator	Indicate if there is an alternative fuel system on board	POWBY	1

Instruction to fill data:

- The Propulsion participation shall be:
 - “BRY” for vessel participating in the propulsion;
 - “BRN” for vessel not participating in the propulsion.

2.3.9.1 Power installations on board (POWBY)

The Power installations on board data type is used by TDET/TINFO component and indicates eventually the presence on board of one or several propulsion or auxiliary systems, which are intended to be used with alternative source of energy.

Components	Description	Type of data	Nb
LNG Indicator	Liquefied/liquid natural gas installation indicator	BOOL	0-1
CNG indicator	Compressed natural gas installation indicator	BOOL	0-1
Methanol indicator	Methanol installation indicator	BOOL	0-1
Compressed hydrogen indicator	Compressed hydrogen installation indicator	BOOL	0-1
Liquified hydrogen indicator	Liquified hydrogen installation indicator	BOOL	0-1
Accumulators installation indicator	Accumulators with a total capacity exceeding 500 kWh	BOOL	0-1

Instruction to fill data:

- As an example, an LNG Indicator set to true, and a Methanol indicator set to true means that there is an LNG system and a methanol system on board and that both may be used as propulsion or auxiliary systems.
- If the vessel or convoy uses only diesel fuel as a source of energy for propulsion or auxiliary systems (or another energy produced on board exclusively from diesel fuel), then all the indicators should be set to "false".

2.3.10 Container totals (CONTAINTOT)

The Container totals data type aims to provide the information of how many containers are transported, by (category of) length and status.

Components	Description	Type of data	Nb
Container's Length Code	Indicates a range for the container's length	TXT(5)	1
Number of Containers	Specification of the number of Containers	POSINT (9999)	1
Container's Status	Indicates whether the containers are empty or full	TXT(1)	1

Instruction to fill data:

- The Container's Length Code shall be:
 - "RNG20" for containers having a length between 20 and 29 feet;
 - "RNG30" for containers having a length between 30 and 39 feet;
 - "RNG40" for containers having a length of 40 feet or more.
- The Container's Status shall be:
 - '4' for loaded;
 - '5' for empty;
 - '6' for no volume available.

2.3.11 Consignment (CONSI)

The "Consignment" data type gives information on the transported cargo.

Components	Description	Type of data	Nb
Sequence Number	Sequence number of the consignment.	POSINT(99999)	1
ETD	Estimated time of departure from the loading place	DATETIME	1
Port of loading	Specification of the loading place of the cargo	LOCID	0-1
Port of Discharge	Specification of the discharge place of the cargo	LOCID	0-1
Cargo receiver	Information on the cargo receiver	PARTYID	0-1
Cargo sender	Information on the cargo sender	PARTYID	0-1

ETA	Estimated time of arrival at the discharge place	DATETIME	0-1
Cargo handling	Describes how the cargo will be handled	TXT(3)	1
Good items details	List of Goods Item	GOIT	1-99

Instruction to fill data:

- For modifications, the same Sequence Number is to be used.
- The Cargo handling shall be:
 - 'T' or 'TRA' for transit,
 - 'LLO' or 'LOA' for loading,
 - 'LDI' or 'DIS' for unloading,
 - 'TSP' for transit in the same port,
 - 'RES' for Re-stow,
 - 'CTC' for Cargo tank cleaning,
 - 'BUN' for Bunkering only,
 - 'DRY' or 'RED' for Repairs in dry-dock,
 - 'WET' or 'REW' for Repairs in wet-dock,
 - 'NCO' for No cargo operation.
- The Good items details should be a list of all Goods Item per vessel and per good.

2.3.11.1 Goods Item (GOIT)

The Good Item data type is used in CONSI. It aggregates the information for each type of good (dangerous or non-dangerous).

Components	Description	Type of data	Nb
Sequence number	Sequence number of the good within a consignment.	POSINT (99999)	1
Number of packages	Number of inner packages related to type of packages.	POSINT (99999999)	0-1
Additional information	Extra goods information	ADDINFO	0-1
Non-dangerous goods info	Information on the non-dangerous goods	NDGINFO	0-1
Dangerous goods info	Information on the dangerous goods	DGINFO	0-1
Good Stowage location info	Indication on the location of goods	STOWINFO	1-99
Inner Package		TXT(2)	0-1

Note: The Sequence Number is unique within the CNI group.

Instruction to fill data:

- For containers and tanks, the Number of packages default value is '1';
- Either Non-dangerous info or Dangerous goods info must be specified (but not both).

2.3.11.2 Non-dangerous goods information (NDGINFO)

The « Non-dangerous goods information » data type contains information on the non-dangerous goods transported by the vessel or the convoy.

Components	Description	Type of data	Nb
Goods name	Goods name of the non-dangerous cargo	TXT(70)	1
NST code	NST code of the non-dangerous cargo	TXT(2-6)	0-1
HS code	HS code of the non-dangerous cargo	TXT(6-10)	0-1
Goods description	Free text to further describe the goods of the non-dangerous cargo	TXT(70)	0-1
Type of Cargo	The required Cargo Type Code based on the Reference Manual on Inland Waterway Transport Statistics (REF#EUROSTAT-IWTS) and conform to Table 19-1	TXT(2)	0-1

Table 19-1
Codelist for type of cargo

Category	Reporting Code	Description
Liquid bulk	1X	Liquid bulk goods (no cargo unit) – Unknown
	13	Oil products
	14	Chemicals
	19	Other liquid bulk goods
Dry bulk	2X	Dry bulk goods (no cargo unit) - Unknown
	21	Ores
	22	Coal
	23	Agricultural products
	24	Construction materials

Category	Reporting Code	Description
	29	Other dry bulk goods
Containers	3X	Large containers - Unknown
	31	20 ft freight units
	32	40 ft freight units
	33	Freight units \u003e 20 ft and \u003c 40 ft
	34	Freight units \u003e 40 ft
	39	Swap bodies
Roll-on roll-off (self-propelled)	5X	Mobile self-propelled units
Roll-on roll-off (non-self-propelled)	6X	Mobile non-self-propelled units
Other general cargo (including small containers)	9X	Other general cargo - Unknown
	91	Forestry products
	92	Iron and steel products
	99	Other cargo, not elsewhere specified
Unknown	XX	Unknown

2.3.11.3 Dangerous goods Information (DGINFO)

The « Dangerous goods information » data type contains information on the dangerous goods transported by the vessel or the convoy.

Components	Description	Type of data	Nb
Dangerous goods	Dangerous goods identification	DGOODS	1
Name	Proper shipping name	TXT(7)	1
Net Weight	Total weight of the dangerous good within a transport	TXT(7)	0-1
UN number	UN number or identification number (Column 1 of the ADN regulation in Tables A (cargo ships) or C (Tankers).)	TXT(4)	1
Transport of dangerous goods in limited quantities	Indicates whether the dangerous goods fall into the category "dangerous goods packed in limited quantities"	BOOL	1

Instruction to fill data:

- The Name of dangerous good should be the proper shipping name, supplemented as necessary with the correct technical name, by which a dangerous substance or article may be correctly identified, or which is sufficiently informative to permit identification by reference to generally available literature.

2.3.11.4 Dangerous goods (DGOODS)

The « Dangerous goods » data type contains information necessary to identify the dangerous goods.

Components	Description	Type of data	Nb
Type of code	Hazard code identification following ADN Classification (Column 3a), or IMDG code, see Part IV, Article 2.03(7) or 2.03(6)	TXT(3)	1
ADN Classification	ADN Classification (Column 3b), see Part IV, Article 2.03(7)	TXT(7)	1
Additional Classification	The ADN Classification in Table A or C (column 3b)	TXT(7)	0-1
UN number	UN number or identification number (Column 1) (UNNR code), see Part IV, 2.03(7), or IMDG number, see 2.03(6)	TXT(4)	1
Flashpoint	The temperature at which the dangerous goods give off sufficient vapour to ignite in air	FLOAT	0-1
Flashpoint Unit	Indicates whether the Flashpoint is in Celsius or Fahrenheit	TXT(3)	0-1
Packing group	Number of the packing group to which belong the transported goods (see column 4 in the ADN table A or C)	TXT(1)	0-1
EMS Number	Emergency procedure (EMS) number	TXT(6)	0-1
Medical First Aid Guide	Medical First Aid Guide (MFAG) number	TXT(4)	0-1
Hazard Placard	Used to identify dangerous goods	HAZ	0-1
Type of Cargo	The required Cargo Type Code based on REF#UNECE-R21 and the Reference Manual on Inland Waterway Transport Statistics	TXT(2)	0-1
HS code	Harmonized System (HS) Code administrated by the World Customs Organization.	TXT(6-10)	0-1
NST code	NST code of the dangerous cargo	TXT(2-6)	0-1

Instruction to fill data:

- The Type of code shall be:
 - 'ADN' for inland vessels (UN/ECE / ADN Code);
 - 'IMD' for sea going vessels (IMO IMDG code).
- The Unit shall be:
 - 'CEL' for Celsius;
 - 'FAH' for Fahrenheit.
- The Packing group shall be:
 - '1' for great danger;
 - '2' for medium danger;
 - '3' for minor danger;
 - Empty if not available.
- Hazard Placard is mandatory for dangerous goods on dry cargo vessels.

2.3.11.5 Hazard Placard (HAZ)

The « Hazard Placard » data type is used to show the nature of the danger that the dangerous goods pose. For more information on the « Hazard Placard » data, see ADN.

Components	Description	Type of data	Nb
Hazard Placard Upper	Hazard identification number, upper part	TXT(4)	0-1
Hazard Placard Lower	Substance identification number, lower part	TXT(4)	0-1

2.3.11.6 Good Stowage location information (STOWINFO)

The « Good Stowage location information » data indicates where the transported goods are stowed.

Components	Description	Type of data	Nb
Vessel	Vessel where goods are stowed	STOWV	1
Location and weight of the cargo	Information on the distribution of goods (and weight) within the containers or tanks	DISTCARGO	0-99

Instruction to fill data:

- If the goods are transported in containers or tanks at least one location in Container is mandatory, specifying the vessel on which the cargo is stowed.

2.3.11.7 Stowage Vessel (STOWV)

For the transported cargo, « Stowage Vessel » data type contains the identification of the vessel (barge) the cargo is stowed on.

Components	Description	Type of data	Nb
Vessel	Identification of the vessel on which the cargo is stowed on	VESSID	1
Gross Weight	Gross Weight (including weight packages)	WEIGHT_K	0-1
Weight of the cargo only	Weight of all cargo in the container (Including innerpackages)	WEIGHT_K	0-1
Observed volume	The observed volume after adjustment for factors such as temperature or gravity	VOLM	0-1

Note:

- Cargo means, in this context, container, liquid cargo and general cargo

2.3.11.8 Additional goods information (ADDINFO)

The “Additional goods information” data type contains more information on the goods transported by the vessel or the convoy.

Components	Description	Type of data	Nb
Type of Good	Indicates whether the goods are Dangerous or non-dangerous	TXT(1)	1
HS code	Harmonized System (HS) Code administrated by the World Customs Organization. No longer in use. Please use HS Code in Non-dangerous goods information or dangerous goods.	TXT(6-10)	0-1
Customs Status	Indicates whether the goods are Union goods	TXT(1)	0-1
Reference Number	Customs document reference number (if any)	TXT(35)	0-1
Overseas Destination	Indicates whether the goods' destination is overseas	TXT(1)	0-1

Instruction to fill data:

- The Type of Good should be:
 - 'D' for Dangerous;
 - 'N' for Non-dangerous.

- The Custom Status should be:
 - 'C' for Union goods;
 - 'F' for Union goods from non-fiscal area;
 - 'N' for All other goods.
- The Overseas Destination should be:
 - 'Y' with overseas destination;
 - 'N' without an overseas destination.

2.3.11.9 Distribution of the Cargo (DISTCARGO)

The Distribution of the Cargo data type contains information on the location of the goods if in containers or tanks.

Components	Description	Type of data	Nb
Container identification	Container identification code	TXT(17)	1
Container Type	Container type following REF#ISO-6346b	TXT(4-4)	0-1
Stowage Location	Place/location identification	TXT(25)	0-1
Gross Weight	Weight of the good in this container	WEIGHT_K	0-1
Weight of cargo	Weight of all cargo in the container (Including innerpackages)	WEIGHT_K	0-1
Volume	Volume of all cargo in the container (Container can be a Tankcontainer.).	VOLM	0-1
Verified Mass	The verified gross mass of this container	WEIGHT	0-1
Estimated Weight	The estimated gross weight of this container	WEIGHT	0-1
Inert Gas	In case of a hazardous gas, a layer of "inert gas" is added so that no oxygen on top can lead to a risk of explosion.	BOOL	0-1

Instruction to fill data:

The Identification Code shall be:

- For containers: The Container identification code (owner code, identifier, serial number, check digit), see Part IV, Article 2.03(13);
- For liquid bulk: 'NA' (applicable when stowed in a tank in a Tanker).
- If the Container Type is known, then this data shall be given.

The Stowage Location shall be for containers:

- 'BBBRRTT' for bay/row/tier (In accordance with REF#ISO 9711-1)

The Stowage Location shall be 'LLnn' for tanks where:

- LL describes the location of the tank:
 - PS for port side;
 - SB for starboard;
 - CC for Center side;
 - CP for Center portside;
 - CS for Center starboard (in case of 4-width configuration).
- nn describes the sequence number of the tank, starting with 01 from front to nn to the back.

ANNEX 20
(DANGEROUS) GOODS REPORTING - ERINOT

TABLE OF CONTENTS

- 1. ERI NOTIFICATION MESSAGE 551**
 - 1.1 Origin of the ERINOT message 551
 - 1.2 Objective of the message 551
 - 1.3 Principles 551
- 2. SPECIFIC DATA TYPE USED FOR ERINOT 551**
 - 2.1 Persons on board and blue cones (PAXBC) 552
 - 2.2 Cancellation Information (CINFO) 553
- 3. GENERAL STRUCTURE OF THE MESSAGE..... 553**
- 4. IMPLEMENTATION OF THE ERINOT MESSAGE 555**

1. ERI notification message

1.1 Origin of the ERINOT message

The ERI notification message (ERINOT) is a specific use of the UN/EDIFACT 'International Forwarding and Transport Dangerous Goods Notification (IFTDGN)' message as it has been developed within the PROTECT organisation.

The ERINOT message in UN/EDIFACT format is based on UN/EDIFACT directory 98.B and Protect version 1.0. The ERINOT message has also been developed in an XML format.

1.2 Objective of the message

The ERINOT message shall be used by boatmasters and on behalf of boatmasters by transport operators and agents for the reporting of dangerous and non-dangerous cargo carried by inland waterway vessels.

The message supports the implementation of the following reporting needs:

- a) Collect safety related data as prescribed by applicable police regulations (River commissions, Member states, local authority like a port)
- b) goods reporting for statistics purposes (Member States level or Eurostat).

1.3 Principles

The IFTDGN message has been accepted by the IMO for the reporting of dangerous goods to authorities. It has been designated as the message from the party responsible to report 'dangerous' goods to the authority performing the control and checks on conformance with the legal requirements. The message is conveying information on the 'dangerous' goods being loaded, discharged or in transit relating to a means of transport.

The notification message based on this standard message can be depicted as follows:

'ERI (Electronic Reporting International) Notification Message' with the following types:

- a) transport notification from vessel to authority from ship to shore;
- b) transport notification from carrier to authority from shore to shore;
- c) passage notification from authority to authority.

2. Specific data type used for ERINOT

This section describes the data type that are used only in ERINOT message. These data types are specific and not described in Annex 20. Generic data types (described in Annex 20) may be slightly modified or adapted for ERINOT. In this case, they will use the same name, with an asterisk, to indicate that it is based on a generic data type.

For each data type, the last column indicates the number of occurrences for a component.

- A fixed number means it is expected to find exactly this number of occurrence(s).
- A range of occurrence means there is a minimum and maximum number of occurrence(s).
- A minimum occurrence of zero means the component is optional and may be absent.

2.1 Persons on board and blue cones (PAXBC)

The « Persons on board and blue cones » data describes the number of persons on board and the number of blue cones for safety reasons.

Components	Description	Type of data	Nb
Blue Cones	Number of blue cones	TXT_UP (1)	0-1
Persons	Total number of persons on board. Crew and Passengers	POSINT (9999)	1
Pax	Number of passengers on board (including stowaways)	POSINT (9999)	0-1
Emergency Phone Number	A phone number to reach the boatmaster of a vessel or somebody who can reach the latter in very short time, in case of emergency	TXT(17)	0-1

Instruction to fill data:

- The Blue Cones field can take the following values:
 - '0', '1', '2', '3' for the number of cones;
 - 'B' for red signal flag;
 - 'V' for special permit.
- The Blue Cones field is optional with the following interpretation:
 - Absence of the field or field with blank or null value shall be interpreted as "no data available", it is also possible that this field is not available because it is not applicable (no ADN cargo);
 - A value of '0' shall be interpreted as the result of the system which calculated zero blue cones.
- If the total number of persons is not known or indicated, the Persons field shall be filled with '9999'.
- Emergency Phone Number: ITU-T Recommendation E.164 gives maximum number length of 15 digits, excluding the international call prefix ('00' or '+').

2.2 Cancellation Information (CINFO)

The Cancellation Information data type aims to describe the reason for the message cancellation. It shall be used only when the function of the message, as defined in MESSINFO, corresponds to a cancellation.

Components	Description	Type of data	Nb
Cancel Reason	Reason for cancelling the message, the possible values are: <ul style="list-style-type: none"> - 'CAM' if there is a mistake in notification; - 'CAO' if the transport does not take place; - 'CAV' if the main transport destination has changed; - 'CHD' if the time of arrival has changed. 	TXT_UP (3)	1
Cancel Text	Free text for further explanation	TXT (70)	1-5

3. General structure of the message

Components	Type of data	Remarks and instructions	Nb
Header	n.a.	Each technical format may need specific header(s) independent of the information carried by the message. These headers are described in the Appendix corresponding to the technical format.	1
Message Type	MESSTYP	Controlling Agency = 'UN' Controlling Agency Level A = 'UNOA' Syntax Version = '2' Message Type = 'IFTDGN' Message Version = 'D' Message Release = '98B' Assigned Code = 'ERI14'	1

Components	Type of data	Remarks and instructions	Nb
Message Information	MESSINFO	<p>Message Type can take the following values:</p> <p>'VES', from vessel to RIS authority message;</p> <p>'CAR', from carrier to RIS authority message;</p> <p>'PAS', passage report from RIS authority to RIS authority.</p> <p>The Function of message can take the following values:</p> <p>'1' for a cancellation message;</p> <p>'9' for a new message, (original);</p> <p>'5' for a modification message;</p> <p>'22' for a final transmission (End of voyage);</p> <p>'150' for an interruption of voyage;</p> <p>'151' for a restart of voyage.</p>	
Persons and Blue Cones	PAXBC	Number of persons on board and the number of blue cones for safety reasons	0-1
Forward to Authority	FWDAUTH	Indicate if this message may be forwarded to other authorities	0-1
Previous Message Number	IDMESS	Reference number to a previous message. This field can be used to relate this message with a previous one.	0-1
Transport Document Number	TREF	Reference number of the transport document	0-1
Test Scenario	SCENAR	Test scenario identification, which shall be known at the receiving party	0-1
Cancellation Information	CINFO	The reason for cancelling the message	0-1
Details of Transport	TDET	Contains information about the dimensions of the transport and its route	1
Sender Address	CONTPARTY	Name and address of message sender	1
Receiver Address	CONTPARTY	Name and address of message receiver	0-1
Agent, Invoice responsible	CONTPARTY		0-1

Components	Type of data	Remarks and instructions	Nb
Barges	BARGINFO	List of Barges	1-99
Containers totals	CONTAINTOT	List of Container totals	1-99
Consignments	CONSI	List of Consignments (similar source/destination) specification of the transported cargo	1-99
Version Major	POSINT(99)		1
Version Minor	POSINT(99)		1

Instructions to fill data:

- The Previous Message Number is a reference to the message for which the current message is a replacement. It shall be the "Message Reference Number" data (in the "Message Information" data) of the message this message replaces. It is mandatory if the message is a modification or a cancellation message.

4. Implementation of the ERINOT message

Only the XML format is available for ERINOT messages.

Appendix 1 XML Edition of ERINOT, XSD file (source code) (Distributed separately)

ANNEX 21
PASSENGER AND CREW LIST - PAXLST

TABLE OF CONTENTS

1. OBJECTIVE OF THE MESSAGE PAXLST..... 559
2. MESSAGE STRUCTURE IN THE UN/EDIFACT FORMAT 560
3. PAXLST MESSAGE IN XML FORMAT 587

1. Objective of the message PAXLST

a) Functional definition

The passenger/crew list message (PAXLST) permits the transfer of passenger or crew data, or both. The message shall be used for the exchange of data in inland navigation between the boatmaster or carrier and designated authorities such as ISPS terminals, customs, immigration, police.

The message shall be also used to transfer passenger/crew data from a designated authority in the country of departure to the appropriate authorities in the country of arrival of the means of transport.

b) Field of application

The passenger/crew list message can be used for both national and international applications. It is based on general practice in administration, commerce and transport, and it is not dependent on the type of business or industry, neither on the mode of transport. The basic concept of the PAXLST message is that there is one message for all crew members for a specified ship on a specified voyage, and another message for the passengers on that voyage whilst also possible stowaways can be reported through a separate message. The messages can be transmitted separately or combined into one transmission.

The message supports the implementation — by means of EDI — of the following reporting needs:

- i) national reporting requirements with respect to crew/passengers and stowaway
- ii) REF#EC2004725 on enhancing ship and port facility security also has provisions related to crew and passenger lists.

Moreover, in accordance with recommended practice set out in the Convention on the Facilitation of International Maritime Traffic, maritime authorities are not to require more than the following information in the crew list:

- iii) Name and nationality of vessel (country of the inspection body that issued the last vessel certificate)
- iv) Family name
- v) Given names
- vi) Nationality
- vii) Rank or rating
- viii) Date and place of birth
- ix) Nature and number of identity document
- x) Port and date of arrival
- xi) Arriving from

In addition, in accordance with the requirements of the competent authorities in inland shipping, the following information might be required:

- xii) Names of visitors to a vessel
- xiii) Licence plates of the vehicles
- xiv) Exact place and time of boarding and going ashore

- xv) Required services such as deliveries, stores and spares
 - xvi) Names of repair people together with company name
 - xvii) Changes of crew
 - xviii) Children of the crew.
- All these details can be exchanged through the PAXLST message.

2. Message structure in the UN/EDIFACT format

The passenger respectively crew list notification is based on the UN/EDIFACT message PAXLST.

The structure for implementation of the crew or passenger list notification message is as follows:

a) Segment index (alphabetical sequence by tag)

- UNH Message header
- BGM Beginning of message
- ATT Attribute
- DOC Document/message details
- DTM Date/time/period
- FTX Free text
- LOC Place/location identification
- NAD Name and address
- RFF Reference
- TDT Details of transport
- UNT Message trailer

b) Segment table

Pos	Tag	Name	S	R
	UNA		C	1
	UNB		M	1
0010	UNH	Message header	M	1
0020	BGM	Beginning of message	M	1
0090		Segment group 2		
0100	TDT	Details of transport	M	1
0110	DTM	Date/time/period	M	1
0120		Segment group 3	M	4
0130	LOC	Place/location identification	M	1
0140	DTM	Date/time/period	M	1
0150		Segment group 4	C	999
0160	NAD	Name and address	M	1
0170	ATT	Attribute	C	1

Pos	Tag	Name	S	R
0180	DTM	Date/time/period	M	1
0210	FTX	Free text	C	1
0220	LOC	Place/location identification	C	3
0270		Segment group 5	C	1
0280	DOC	Document/message details	M	1
0290	DTM	Date/time/period	C	1
0320	LOC	Place/location identification	C	1
0440	UNT	Message trailer	M	1

c) Branching diagram

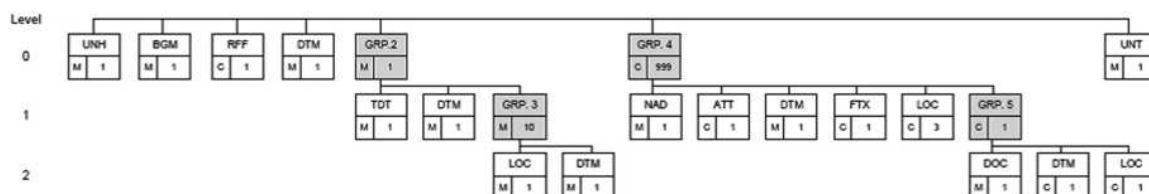

d) Passenger / Crew list message format in UN/EDIFACT format

Segment Group	Segment Composite data element (C) Data element TAG	Level	Status	Format	Name	Description Qualifiers in quotation marks
1	2	3	4	5	6	7
	UNA	0	C		Service String Advice	
			M	an1	Component data element separator	
			M	an1	Segment Tag and Data element separator	+
			M	an1	Decimal notation	
			M	an1	Release indicator	?
			M	an1	Reserved future use	space
			M	an1	Segment terminator	'
					<i>Advised string: UNA:+.? '</i>	6 characters
	UNB	0	M		Interchange header	
	S001		M		SYNTAX IDENTIFIER	
		0001	M	a4	Syntax identifier	'UNOC' Controlling agency
		0002	M	n1	Syntax version number	'2'
	S002		M		INTERCHANGE SENDER	

1	2	3	4	5	6	7
	0004		M	an..35 (an25)	Sender identification	Mailbox number or unique name or the unique identifier of a RIS-centre or traffic post
	0007			an..4	Partner identification code qualifier	n.a.
	0008			an..14	Address for reverse routing	n.a.
	S003		M		INTERCHANGE RECIPIENT	
	0010		M	an..35 (an25)	Recipient identification	Mailbox number or unique name or the unique identifier of a RIS-centre or traffic post
	0007			an..4	Partner identification code qualifier	n.a.
	0014			an..14	Routing address	n.a.
	S004		M		DATE/TIME OF PREPARATION	
	0017		M	n6	Date	Generation date, YYMMDD
	0019		M	n4	Time	Generation time, HHMM
	0020		M	an..14	Interchange reference identification.	First 14 positions of the message reference number
	S005		C		RECIPIENTS REFERENCE, PASSWORD	n.a.
	0022			an..14	Recipient's reference/password	n.a.
	0025			an2	Recipient's reference, password qualifier	n.a.
	0026			an..14	Application reference	n.a.
	0029			a1	Processing priority code	n.a.
	0031		C	n1	Acknowledgement request	'1' = Sender requests acknowledgement, i.e. UNB and UNZ segments received and identified

1	2	3	4	5	6	7
	0032			an..35	Communications agreement id	n.a.
	0035		C	n1	Test indicator	'1' = the interchange relates to a test message
	UNH		M		MESSAGE HEADER	Identification, specification and heading of a message
	0062		M	an..14	Message reference number	First 14 positions of the message number
	S009		M		MESSAGE IDENTIFIER	Message identification
		0065	M	an..6	Message type	'PAXLST', message type
		0052	M	an..3	Message version number	'D', message version number
		0054	M	an..3	Message release number	'05A', message release number
		0051	M	an..2	Controlling agency	'UN', controlling agency
		0057	M	an..6	Association assigned code	'ERI14', ERI Version 1.4
	0068		M	an..35	Common access reference	Common access reference Reference to all messages related to one common file
	S010				STATUS OF THE TRANSFER	Transfer status
		0070		n..2	Sequence of transfers	n.a.
		0073		a1	First and last transfer	n.a.
	BGM	0	M		BEGINNING OF MESSAGE	Identification of the type and function of the message

1	2	3	4	5	6	7
	C002				Document/message name	Message name
	1001		M	an..3	Document name code	Message type: '250' crew list 745' passenger list '10' stowaway list
	1131			an..17	Code list identification code	n.a.
	3055			an..3	Code list responsible agency code	n.a.
	1000		M	an..35	Document name	Document name: 'CREW LIST' 'PASSENGER LIST' 'STOWAWAY LIST' (One PAXLST message contains one document.)
	C106		M		Document/message identification	
	1004		M	an..35 an(15)	Document identifier	message reference number
	1056		C	an..9	Version identifier	version identifier
	1060		C	an..6	Revision identifier	revision identifier

1	2	3	4	5	6	7
	1225		M	an..3	MESSAGE FUNCTION CODE	Function of message '1' = cancellation message '9' = new message (original) '5' = modification message '22' = Final transmission (End of voyage) '150' = Interruption of voyage '151' = Restart of voyage
	4343			an..3	RESPONSE TYPE CODE	QA
	RFF	0	C		REFERENCE	Reference to the message which is changed, mandatory if the message is a modification message
	C506		M		REFERENCE	Reference
	1153		M	an..3	Reference qualifier	'ACW'
		1154	M	an..35	Reference number	(an14) message reference number of the BGM, tag 1004 of the message the current message refers to
		1156		an..6	Line number	n.a.
		4000		an..35	Reference version number	n.a.
		1060		an..35	Revision number	n.a.
	DTM	0	M		DATE/TIME/PERIOD	
	C507		M		DATE/TIME/PERIOD	Date/time/period

1	2	3	4	5	6	7
	2005		M	an..3	Date or time or period function code qualifier	'184' Notification date
	2380		M	an..35	Date or time period value	Time: CCYYMMDD
	2379		M	an..3	Date or time or period format code	'102'
	TDT	1	M		Specification of the means of transport	Specification of the means of transport, the naming vessel within a convoy (a single vessel without barge is also a convoy in this context)
	8051		M	an..3	'20' (main transport)	Transport stage code qualifier
	8028		C	an..17	Conveyance reference number	Voyage number, defined by sender of the message
	C220		M		Transport modality	n.a.
	8067		M	an..3	Mode of transport, coded	'8' for inland water transport, '1' for maritime transport (see REF#UNECE-R19)
	8066			an..17	Transport mode name	n.a.
	C001		M		Type of means of transport identification, convoy type	Code for ship and convoy types of means of transport from UNCEFACT Rec. 28, see Part IV, Article 2.03(1)
	8179			an..8	Transport means description code	n.a.
	1131			an..17	Code list identification code	n.a.
	3055			an..3	Code list responsible agency code	n.a.
	8178			an..17	Transport means description	n.a.
	C040				Carrier	

1	2	3	4	5	6	7
	3127			an..17	Carrier identifier	n.a.
	1131			an..17	Code list identification code	n.a.
	3055			an..3	Code list responsible agency code	n.a.
	3128			an..35	Carrier name	n.a.
	8101			an..3	Transit direction indicator code	n.a.
	C401				Excess transportation information	n.a.
	8457			an..3	Excess transportation reason code	n.a.
	8459			an..3	Excess transportation responsibility code.	n.a.
	7130			an..17	Customer shipment authorisation identifier	n.a.
	C222		M		Transport identification	
	8213		M	an..9 (an7..8)	ID. of means of transport identification	<i>Vessel number.</i> 7 digits for IMO indication, 8 digits for unique European vessel identification number (ENI)
	1131		M	an..17	Code list qualifier	'IMO' for an IMO number, see Part IV, Article 2.03(2) 'ENI' for a unique European vessel identification number, see Part IV, Article 2.03(3)
	3055			an..3	Code list responsible agency code	n.a.
	8212		M	an..35	Name of the vessel	<i>Name of the ship.</i> If the name results in more than 35 positions, the name of the vessel is shortened.

1	2	3	4	5	6	7
	8453		M	an..3	(an2) Nationality, REF#ISO-3166 country code	REF#ISO-3166-1 two-alpha country code, see Part IV, Article 2.03(8) Dependency note. The country of the inspection body that issued the last vessel certificate.
	8281			an..3	Transport means ownership indicator code.	n.a.
TDT	DTM	1	M	TDT(20)	Estimated time of arrival/departure	
	C507				Date/time/period	
	2005		M	an..3	Date or time or period function code qualifier	'132' for arrival '133' for departure
	2380		M	an..35	Date or time period value	Given in the local time of the place of arrival
	2379		M	an..3	Date or time or period format code	'203' for CCYYMMDDHHMM
TDT	LOC(1)	1	M		PLACE/LOCATION IDENTIFICATION	<i>Port of departure</i> , the port where the transport starts
	3227		M	an..3	Place/location qualifier	'5' place of departure
	C517		M		LOCATION IDENTIFICATION	
	3225		M	an..35 (an5)	Place/location identification	REF#UNECE-R16 location code, see Part IV, Article 2.03(9)
	1131			an..17	Code list qualifier	n.a.
	3055			an..3	Code list responsible agency	n.a.

1	2	3	4	5	6	7
	3224		D[Use 1]	an..256 (an..17)	Place/location	Full name of the port location
	C519		C		RELATED LOCATION ONE IDENTIFICATION	
	3223		M	an..25 (an..5)	Related place/location one identification	Terminal code, Part IV, Article 2.03(11)
	1131			an..17	Code list qualifier	n.a.
	3055			an..3	Code list responsible agency	n.a.
	3222		D[Use 1]	an..70	Related place/location one	Full name of the terminal
	C553		C		RELATED LOCATION TWO IDENTIFICATION	
	3233		M	an..25 (an5)	Related place/location two identification	Fairway section code, see Part IV, Article 2.03(10)
	1131			an..17	Code list qualifier	n.a.
	3055			an..3	Code list responsible agency	n.a.
	3232		C	an..70 (an..5)	Related place/location two	Fairway section hectometre
	5479			an..3	Relation	n.a.
TDT/LOC1	DTM	1	M		Estimated time of departure	
	C507				Date/time/period	

1	2	3	4	5	6	7
	2005		M	an..3	Date or time or period function code qualifier	'133' for departure
	2380		M	an..35	Date or time period value	Given in the local time of the place of arrival
	2379		M	an..3	Date or time or period format code	'203' for CCYYMMDDHHMM
TDT	LOC(2)	1	M		PLACE/LOCATION IDENTIFICATION	First port of call
	3227		M	an..3	Place/location qualifier	'87'
	C517		M		LOCATION IDENTIFICATION	
	3225		M	an..35 (an5)	Place/location identification	REF#UNECE-R16 location code, see Part IV, Article 2.03(9)
	1131			an..17	Code list qualifier	n.a.
	3055			an..3	Code list responsible agency	n.a.
	3224		D[Use 1]	an..256 (an..17)	Place/location	Full name of the port location
	C519		C		RELATED LOCATION ONE IDENTIFICATION	
	3223		M	an..25 (an..5)	Related place/location one identification	Terminal code, see Part IV, Article 2.03(11)
	1131			an..17	Code list qualifier	n.a.
	3055			an..3	Code list responsible agency	n.a.
	3222		D[Use 1]	an..70	Related place/location one	Full name of the terminal

1	2	3	4	5	6	7
	C553		C		RELATED LOCATION TWO IDENTIFICATION	
	3233		M	an..25 (an5)	Related place/location two identification	Fairway section code, see Part IV, Article 2.03(10)
	1131			an..17	Code list qualifier	n.a.
	3055			an..3	Code list responsible agency	n.a.
	3232		C	an..70 (an..5)	Related place/location two	Fairway section hectometre
	5479			an..3	Relation	n.a.
TDT/LOC 2	DTM	1	M		Estimated time of first port of call	
	C507				Date/time/period	
	2005		M	an..3	Date or time or period function code qualifier	'252' Arrival date/time at initial port
	2380		M	an..35	Date or time period value	Given in the local time of the place of arrival
	2379		M	an..3	Date or time or period format code	'203' for CCYYMMDDHHMM
TDT	LOC(3)	1	M		PLACE/LOCATION IDENTIFICATION	Last port of call
	3227		M	an..3	Place/location qualifier	'125'
	C517		M		LOCATION IDENTIFICATION	

1	2	3	4	5	6	7
	3225		M	an..35 (an5)	Place/location identification	REF#UNECE-R16 location code, see Part IV, Article 2.03(9)
	1131			an..17	Code list qualifier	n.a.
	3055			an..3	Code list responsible agency	n.a.
	3224		D[Use 1]	an..256 (an..17)	Place/location	Full name of the port location
	C519		C		RELATED LOCATION ONE IDENTIFICATION	
	3223		M	an..25 (an..5)	Related place/location one identification	Terminal code, see Part IV, Article 2.03(11)
	1131			an..17	Code list qualifier	n.a.
	3055			an..3	Code list responsible agency	n.a.
	3222		D[Use 1]	an..70	Related place/location one	Full name of the terminal
	C553		C		RELATED LOCATION TWO IDENTIFICATION	
	3233		M	an..25 (an5)	Related place/location two identification	Fairway section code, see Part IV, Article 2.03(10)
	1131			an..17	Code list qualifier	n.a.
	3055			an..3	Code list responsible agency	n.a.
	3232		C	an..70 (an..5)	Related place/location two	Fairway section hectometre
	5479			an..3	Relation	n.a.

1	2	3	4	5	6	7
TDT/LOC 3	DTM	1	M		Estimated time of arrival/departure	
	C507				Date/time/period	
	2005		M	an..3	Date or time or period function code	'253' Departure date/time from last port of call qualifier
	2380		M	an..35	Date or time period value	Given in the local time of the place of arrival
	2379		M	an..3	Date or time or period format code	'203' for CCYYMMDDHHMM
TDT	LOC(4)	1	M		PLACE/LOCATION IDENTIFICATION	Port of arrival
	3227		M	an..3	Place/location qualifier	'60'
	C517		M		LOCATION IDENTIFICATION	
	3225		M	an..35 (an5)	Place/location identification	REF#UNECE-R16 location code, see Part IV, Article 2.03(9)
	1131			an..17	Code list qualifier	n.a.
	3055			an..3	Code list responsible agency	n.a.
	3224		D[Use 1]	an..256 (an..17)	Place/location	Full name of the port location
	C519		C		RELATED LOCATION ONE IDENTIFICATION	
	3223		M	an..25 (an..5)	Related place/location one identification	Terminal code, see Part IV, Article 2.03(11)

1	2	3	4	5	6	7
	1131			an..17	Code list qualifier	n.a.
	3055			an..3	Code list responsible agency	n.a.
	3222		D[Use 1]	an..70	Related place/location one	Full name of the terminal
	C553		C		RELATED LOCATION TWO IDENTIFICATION	
	3233		M	an..25 (an5)	Related place/location two identification	Fairway section code, see Part IV, Article 2.03(10)
	1131			an..17	Code list qualifier	n.a.
	3055			an..3	Code list responsible agency	n.a.
	3232		C	an..70 (an..5)	Related place/location two	Fairway section hectometre
	5479			an..3	Relation	n.a.
TDT/LOC 4	DTM	1	M		Estimated time of arrival/departure	
	C507				Date/time/period	
	2005		M	an..3	Date or time or period function code qualifier	'132' for arrival
	2380		M	an..35	Date or time period value	Given in the local time of the place of arrival
	2379		M	an..3	Date or time or period format code	'203' for CCYYMMDDHHMM
GRP 4	NAD	0	M		NAME and ADDRESS	Name and address details of person

1	2	3	4	5	6	7
	3035		M	an..3	Party function code qualifier	Name type: 'FM' for crew member 'FL' for passenger 'BV' for stowaway persons
	C082		C		PARTY IDENTIFICATION DETAILS	Name identification
		3039		an..35	Party identification	Code or textual description of the relation
		1131		an..17	Code list qualifier	n.a.
		3055		an..3	Code list responsible agency	n.a.
	C058		M		NAME AND ADDRESS	n.a.
		3124	M	an..35	Name and address line	Family name
		3124	M	an..35	Name and address line	Given names
		3124	C	an..35	Name and address line	Prefix (gender)
		3124		an..35	Name and address line	n.a.
		3124		an..35	Name and address line	n.a.
	C080		C		PARTY NAME	
		3036		an..35	Party name	n.a.
		3036		an..35	Party name	n.a.
		3036		an..35	Party name	n.a.
		3036		an..35	Party name	n.a.
		3036		an..35	Party name	n.a.

1	2	3	4	5	6	7
	3045			an..3	Party name format, coded	n.a.
	C059		C		STREET	
	3042		C	an..35	Street and number/PO box	Street and number or post office box
	3042			an..35	Street and number/PO box	n.a.
	3042			an..35	Street and number/PO box	n.a.
	3042			an..35	Street and number/PO box	n.a.
	3164		C	an..35	City name	City
	C819		C		Country sub-entity identification	n.a.
	3229		C	an..9	Country sub-entity name code	Postal identification code
	1131		C	an..17	Code list identification code	n.a.
	3055			an..3	Code list responsible agency code	n.a.
	3228			an..70	Country sub-entity name	n.a.
	3251		C	an..17	postal code	
	3207		M	an..3	(an2) nationality, REF#ISO-3166 country code	REF#ISO-3166-1 two alpha country code, see Part IV, Article 2.03(8)
GRP 4	ATT	1	C		Rank/title	Rank/title
	9017		M	an..3	Attribute function qualifier	'5' Professional title '1' Crew member
	C955		C		Attribute type	

1	2	3	4	5	6	7
	9021			an..17	Attribute type, coded	
	1131			an..17	Code list identification code	n.a.
	3055			an..3	Code list responsible agency code	n.a.
	9020			an..70	Attribute type description	n.a.
	C956		C		Attribute detail	
	9019			an..17	Attribute description code	n.a.
	1131			an..17	Code list identification code	n.a.
	3055			an..3	Code list responsible agency code	n.a.
	9018		M	an..256	Attribute description	Rank/title name e.g. Chief officer
NAD	DTM	1	M		DATE/TIME/PERIOD	Date of birth
	C507				Date/time/period	Date/time/period
	2005		M	an..3	Date or time or period function code qualifier	'329'
	2380		M	an..35	Date or time period value	Date: CCYYMMDD
	2379		M	an..3	Date or time or period format code	'102'
NAD	FTX	1	C		Free text	General information

1	2	3	4	5	6	7
	4451		M	an..3	Text subject qualifier	Text subject type 'AAI' General Information
	4453			an..3	Text function, coded	
	C107		C		Text reference	
	4441		M	an..17	Free text, coded	Call information related to boarding of persons. General information on the call of the vessel.
	1131			an..17	Code list qualifier	n.a.
	3055			an..3	Code list responsible agency, coded	n.a.
	C108		C		Text literal	
	4440		C	an..512	Free text	License number vehicle
	4440		C	an..512	Free text	Visitor
	4440		C	an..512	Free text	Company name of service provider and other details
	4440		C	an..512	Free text	Names and duration of visit of the visiting children
	4440		D[Use 2]	an..512	Free text	Health Status
	3453			an..3	Language, coded.	
	4447			an..3	Text formatting, coded	
NAD	LOC(1)		M		PLACE/LOCATION IDENTIFICATION	Place of birth
	3227		M	an..3	Place/location qualifier	'180'

1	2	3	4	5	6	7
	C517		M		LOCATION IDENTIFICATION	
		3225	C	an..35 (an5)	Place/location identification	REF#ISO-3166-1 two alpha country code, see Part IV, Article 2.03(8)
		1131		an..17	Code list qualifier	n.a.
		3055		an..3	Code list responsible agency	n.a.
		3224	M	an..256 (an..35)	Place/location	Place of birth
	C519		C		RELATED LOCATION ONE IDENTIFICATION	n.a.
		3223		an..35	Related place/location one identification	n.a.
		1131		an..17	Code list qualifier	n.a.
		3055		an..3	Code list responsible agency	n.a.
		3222		an..70	Related place/location one	n.a.
	C553				RELATED LOCATION TWO IDENTIFICATION	n.a.
		3233		an..25	Related place/location two identification	n.a.
		1131		an..17	Code list qualifier	n.a.
		3055		an..3	Code list responsible agency	n.a.
		3232		an..70	Related place/location two	n.a.
	5479			an..3	Relation	n.a.

1	2	3	4	5	6	7
NAD	LOC(2)		M		PLACE/LOCATION IDENTIFICATION	Place of Embarkation
	3227		M	an..3	Place/location qualifier	'178' for place of Embarkation
	C517		M		LOCATION IDENTIFICATION	
	3225		C	an..35 (an5)	Place/location identification	REF#UNECE-R16 location code of the port, see Part IV, Article 2.03(9)
	1131			an..17	Code list qualifier	n.a.
	3055			an..3	Code list responsible agency	n.a.
	3224		D[Use 1]	an..256	Place/location	Full name of the port location
	C519		C		RELATED LOCATION ONE IDENTIFICATION	
	3223		M	an..35 (an5)	Related place/location one identification	Terminal code, see Part IV, Article 2.03(11)
	1131			an..17	Code list qualifier	n.a.
	3055			an..3	Code list responsible agency	n.a.
	3222		D[Use 1]	an..70	Related place/location one	Full name of the terminal
	C553		C		RELATED LOCATION TWO IDENTIFICATION	
	3233		M	an..35 (an5)	Related place/location two identification	Fairway section code, see Part IV, Article 2.03(10)
	1131			an..17	Code list qualifier	
	3055			an..3	Code list responsible agency	n.a.

1	2	3	4	5	6	7
	3232		C	an..70 (an5)	Related place/location two	Fairway section hectometre
	5479			an..3	Relation	n.a.
NAD	LOC(3)		M		PLACE/LOCATION IDENTIFICATION	Place of Disembarkation
	3227		M	an..3	Place/location qualifier	'179' for place of disembarkation
	C517		M		LOCATION IDENTIFICATION	
	3225		C	an..35 (an5)	Place/location identification	REF#UNECE-R16 location code of the port, see Part IV, Article 2.03(9)
	1131			an..17	Code list qualifier	n.a.
	3055			an..3	Code list responsible agency	n.a.
	3224		D[Use 1]	an..256	Place/location	Full name of the port location
	C519		C		RELATED LOCATION ONE IDENTIFICATION	
	3223		M	an..25 (an5)	Related place/location one identification	Terminal code, see Part IV, Article 2.03(11)
	1131			an..17	Code list qualifier	n.a.
	3055			an..3	Code list responsible agency	n.a.
	3222		D[Use 1]	an..70	Related place/location one	Full name of the terminal
	C553		C		RELATED LOCATION TWO IDENTIFICATION	

1	2	3	4	5	6	7
	3233		M	an..25 (an5)	Related place/location two identification	Fairway section code, see Part IV, 2.03(10)
	1131			an..17	Code list qualifier	
	3055			an..3	Code list responsible agency	n.a.
	3232		C	an..70 (an5)	Related place/location two	Fairway section hectometre
	5479			an..3	Relation	n.a.
NAD	DOC	1	M		Travel document details	Travel document details
	C002		M		Document/message name	Document/message name
	1001		M	n..3	Document/message name, coded	Document type: '39' Passport '36' Identity card 'SMB' Seaman's book '40' Driving licence (national) '41' Driving licence (international) '483' Visa
	1131			an..17	Code list qualifier	n.a.
	3055			an..3	Code list responsible agency, coded	n.a.
	1000		C	an..35	Document name	Type of Visa
	C503		M		Document/message details	

1	2	3	4	5	6	7
	1004		M	an..35	Document/message number	Document identifier
	1373			an..3	Document/message status, coded	n.a.
	1366			an..70	Document/message source	n.a.
	3453			an..3	Language, coded	n.a.
	1056			an..9	Version	n.a.
	1060			an..6	Revision number	n.a.
	3153			an..3	Communication channel identifier, coded	n.a.
	1220			n..2	Number of copies of document required	n.a.
	1218			n..2	Number of originals of document required	n.a.
DOC	DTM	2	C		DATE/TIME/PERIOD	Expiration date
	C507				Date/time/period	Date/time/period
	2005		M	an..3	Date or time or period function code qualifier	'192'
	2380		M	an..35	Date or time period value	Date: CCYYMMDD
	2379		M	an..3	Date or time or period format code	'102'
TDT	LOC(1)	1	M		PLACE/LOCATION IDENTIFICATION	Place of issue of document
	3227		M	an..3	Place/location qualifier	'44'

1	2	3	4	5	6	7
	C517		M		LOCATION IDENTIFICATION	
		3225	C	an..35 (an5)	Place/location identification	REF#UNECE-R16 location code, see Part IV, Article 2.03(9)
		1131		an..17	Code list qualifier	n.a.
		3055		an..3	Code list responsible agency	n.a.
		3224		an..256	Place/location	n.a.
	C519				RELATED LOCATION ONE IDENTIFICATION	n.a.
		3223		an..25	Related place/location one identification	n.a.
		1131		an..17	Code list qualifier	n.a.
		3055		an..3	Code list responsible agency	n.a.
		3222		an..70	Related place/location one	n.a.
	C553				RELATED LOCATION TWO IDENTIFICATION	n.a.
		3233		an..25	Related place/location two identification	n.a.
		1131		an..17	Code list qualifier	n.a.
		3055		an..3	Code list responsible agency	n.a.
		3232		an..70 (an..5)	Related place/location two	n.a.
	5479			an..3	Relation	n.a.

1	2	3	4	5	6	7
	UNT	0	M		MESSAGE TRAILER	End and control of completeness of the message
	0074		M	n..6	Number of segments in the message	
	0062		M	an..14	First 14 positions of the message reference number	First 14 positions of the message reference number
	UNZ		M		INTERCHANGE TRAILER	End and control of the interchange
	0036		M	n..6	Interchange control count	'1' for number of messages contained in the interchange
	0020		M	an..14	Interchange control reference	First 14 positions of the message reference number

Business rules	
D[USE 1]	If the code is XXXXX, then this data-element shall be completed.
D[USE 2]	This data-element is mandatory if person requires additional support.

3. PAXLST message in XML format

In the PAXLST message structure in UN/EDIFACT format, the column 'Description Qualifiers in quotation marks' indicates which information should be provided in a particular data element, including additional restrictions on size and allowed character set.

In the XSD, these fill-in instructions are included in the 'xs:annotation' field of the respective data elements. This field also integrates a subfield 'xs:documentation' which indicates the corresponding field name of the UN/EDIFACT format.

Besides, the instructions which are applicable for the UN/EDIFACT format are also applicable by default in the XSD. If additional information or deviating restrictions are required, it will be provided in this field.

Appendix 1 PAXLST message in XML format, XSD file (source code) (Distributed separately)

ANNEX 22
ERI RESPONSE AND RECEIPT MESSAGE - ERIRSP

TABLE OF CONTENTS

1. ERIRSP MESSAGE..... 591

2. ERI RESPONSE MESSAGE ERIRSP IN UN/EDIFACT FORMAT 591

3. XML FORMAT OF ERIRSP MESSAGE 603

4. ERROR CODES 603

1. ERIRSP message

This message shall be used to provide where required answering and response functions to sent messages.

The function of this message is:

- to inform a message issuer that his ERI message has been received by the addressee's application and has been rejected due to errors encountered during its processing in the application;
- to acknowledge to a ERI message issuer the receipt of his message by the addressee's application.

a) Field of application

The application error and acknowledgement message can be used for both national and international applications. It is not dependent on the type of business or industry, neither it is a legal requirement: it is based on business practices related to administration and transport.

b) Principles

An ERI message can first be controlled at system level (e.g. the CONTRL message) to detect syntax errors and to acknowledge its receipt. It shall be then transmitted to the application process to be processed.

When an acknowledgement is necessary an ERIRSP message shall be sent specifying the reasons of acknowledgement. If an error is detected at the application level, which prevents its complete processing, an ERIRSP message shall be sent to the original message issuer providing details of the error(s) encountered. In case of application error, the ERIRSP message shall be transmitted manually.

In case of acknowledgement the ERIRSP message shall be processed automatically or manually, at recipient's discretion.

2. ERI RESPONSE MESSAGE ERIRSP in UN/EDIFACT format

The ERIRSP message is derived from the UN/EDIFACT APERAK message. The response messages to the functions (new, modification or cancellation) of the notification message ERINOT have all the same structure. The response to a 'modification' or a 'cancellation' contains information whether or not the 'modification' or 'cancellation' has been processed by the receiving system. A response is required only if the NAD (1)/COM segment, with qualifier 'EI', contains the mailbox number, or with qualifier 'EM', contains the email address where the response is to be returned to.

- a) Segment index (alphabetical sequence by tag)
- BGM Beginning of message
 - COM Communication contact
 - DTM Date/time/period
 - ERC Application error information
 - FTX Free text
 - NAD Name and address
 - RFF Reference
 - UNH Message header
 - UNT Message trailer
- b) Segment table

Pos	Tag	Name	S	R
	UNB		M	1
0010	UNH	Message header	M	1
0020	BGM	Beginning of message	M	1
0030	DTM	Date/time/period	M	1
0060		Segment group 1	C	2
0070	RFF	Reference	M	1
0090		Segment group 2	C	1
0100	NAD	Name and address	M	1
0120	COM	Communication contact	C	3
0130		Segment group 3	D[1]	9
0140	ERC	Application error information	M	1
0150	FTX	Free text	M	1
0190	UNT	Message trailer	M	1

Business rules	
D[1]	This segment-group is to be used if any application error(s) occur.

c) Branching diagram

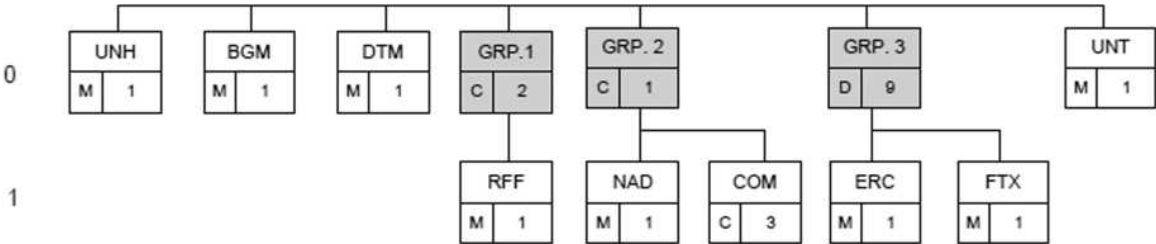

- d) ERIRSP message structure in UN/EDIFACT format
Table 22-1 defines the segments of the ERI response messages.

Table 22-1
ERI response message ERIRSP

Segment Group	Segment Composite data element (C) Data element TAG	Level	Status	Format	Name	Description Qualifiers in quotation marks
1	2	3	4	5	6	7
	UNB	0	M		INTERCHANGE HEADER	
	S001		M		SYNTAX IDENTIFIER	
	0001		M	a4	Syntax identifier	'UNOA' Controlling agency
	0002		M	n1	Syntax version number	'2'
	S002		M		INTERCHANGE SENDER	
	0004		M	an..35 (an25)	Sender identification	Mailbox number or unique name or the unique identifier of a RIS-centre or traffic post
	0007			an..4	Partner identification code qualifier	n.a.
	0008			an..14	Address for reverse routing	n.a.
	S003		M		INTERCHANGE RECIPIENT	
	0010		M	an..35 (an25)	Recipient identification	Mailbox number or unique name or the unique identifier of a RIS-centre or traffic post
	0007			an..4	Partner identification code qualifier	n.a.

1	2	3	4	5	6	7
	0014			an..14	Routing address	n.a.
	S004		M		DATE/TIME OF PREPARATION	ho
	0017		M	n6	Date	Generation date, YYMMDD
	0019		M	n4	Time	Generation time, HHMM
	0020		M	an..14	Interchange control reference	First 14 positions of the message reference number
	S005				RECIPIENTS REFERENCE, PASSWORD	
	0022			an..14	Recipient's reference/password	n.a.
	0025			an2	Recipient's reference, password qualifier	n.a.
	0026			an..14	Application reference	n.a.
	0029			a1	Processing priority code	n.a.
	0031			n1	Acknowledgement request	n.a.
	0032			an..35	Communications agreement id	n.a.
	0035		C	n1	Test indicator	'1' = the interchange relates to a test message
	UNH	0	M		MESSAGE HEADER	Identification, specification and heading of a message
	0062		M	an..14	Message reference number	First 14 positions of the message reference number
	S009		M		MESSAGE IDENTIFIER	
	0065		M	an..6	Message type	'APERAK', message type

1	2	3	4	5	6	7
	0052		M	an..3	Message version number	'O'
	0054		M	an..3	Message release number	'98B'
	0051		M	an..2	Controlling agency	'UN'
	0057		M	an..6	Association assigned code	'ERI14', ERI Version 1.4
	0068			an..35	Common access reference	n.a.
	S010				STATUS OF THE TRANSFER	
	0070			n..2	Sequence of transfers	n.a.
	0073			a1	First and last transfer	n.a.
	BGM	0	M		BEGINNING OF MESSAGE	Identification of the type and function of the message
	C002		M		DOCUMENT/MESSAGE NAME	
	1001		M	an..3	Document/message name code	Type of message received for which this message contains the acknowledgement information: 'VES', from vessel to RIS authority message 'CAR', from carrier to RIS authority message 'PAS', passage report from RIS authority to RIS authority
	1131			an..3	Code list qualifier	n.a.
	3055			an..3	Code list responsible agency	n.a.
	1000			an..35	Document/message name	n.a.

1	2	3	4	5	6	7
	C106		M		DOCUMENT/MESSAGE IDENTIFICATION	
	1004		M	an..35 (an15)	Document identifier	Message reference number. This number shall be as unique as possible, both for sender and for receiver. If a message is received and then passed on to another receiver, the original message reference number shall be used. The transitional system shall in this case not generate another message reference number.
	1056			an..9	Version	n.a.
	1060			an..6	Revision number	n.a.
	1225		M	an..3	Message function code	Function of message: '9' = new message (original)
	4343		M	an..3	Response type code	'AP' accepted 'RE' rejected. The notification is rejected if the transport is already arrived at its destination.
	DTM	1	M		DATE/TIME/PERIOD	The date/time that the receiving application encounters the approval or rejection
	C507		M		DATE/TIME/PERIOD	
	2005		M	an..3	Date or time or period function code qualifier	'137' for document/message date/time
	2380		M	an..35	Date or time period value	Value of arrival time: YYMMDDHHMM
	2379		M	an..3	Date or time or period format code	'201' for YYMMDDHHMM

1	2	3	4	5	6	7
GRP 1	RFF (1)	1	C		REFERENCE	Reference to previous message
	C506		M		REFERENCE	
	1153		M	an..3	Reference qualifier	'ACW' for reference number to previous message
	1154		M	an..35	Reference number	Message reference number from BGM, TAG 1004 of the message this message refers to
	1156			an..6	Line number	n.a.
	4000			an..35	Reference version number	n.a.
	1060			an..6	Revision number	n.a.
GRP 1	RFF (2)	1	C		REFERENCE	Reference to transaction/invoice number
	C506		M		REFERENCE	
	1153		M	an..3	Reference qualifier	'AAY' for reference number to transaction
	1154		M	an..35	Reference number	Reference number assigned by the receiving authority. The reference number shall start with the UN country code followed by three positions for the assigning system. The final part is the actual reference number.
	1156			an..6	Line number	n.a.
	4000			an..35	Reference version number	n.a.
	1060			an..6	Revision number	n.a.

1	2	3	4	5	6	7
GRP 2	NAD	1	M		NAME and ADDRESS	Name and address of the sender of the notification
	3035		M	an..3	Party function code qualifier	'MS' for message sender
	C082				PARTY IDENTIFICATION DETAILS	n.a.
		3039		an..35	Party identification	n.a.
		1131		an..3	Code list qualifier	n.a.
		3055		an..3	Code list responsible agency	n.a.
	C058				NAME AND ADDRESS	n.a.
		3124		an..35	Name and address line	n.a.
		3124		an..35	Name and address line	n.a.
		3124		an..35	Name and address line	n.a.
		3124		an..35	Name and address line	n.a.
		3124		an..35	Name and address line	n.a.
	C080		M		PARTY NAME	
		3036	M	an..35	Party name	Name of the sender of the notification
		3036		an..35	Party name	n.a.
		3036		an..35	Party name	n.a.
		3036		an..35	Party name	n.a.
		3036		an..35	Party name	n.a.

1	2	3	4	5	6	7
	3045			an..3	Party name format, coded	n.a.
	C059		C		STREET	
	3042		M	an..35	Street and number/PO box	Street and number or post office box
	3042			an..35	Street and number/PO box	n.a.
	3042			an..35	Street and number/PO box	n.a.
	3042			an..35	Street and number/PO box	n.a.
	3164		C	an..35	City name	City
	3229			an..9	Country sub-entity identification	n.a.
	3251		C	an..9	Postcode identification	Postal identification code
	3207		C	an..3	Country	REF#ISO-3166-1 two alpha country code, see Part IV, Article 2.03(8)
NAD	COM	2	C		COMMUNICATION CONTACT	Sender communication contact details (maximum 3 times)
	C076		M		COMMUNICATION CONTACT	
	3148		M	an..70	Communication number	Communication number
	3155		M	an..3	Communication channel qualifier	'TE' for telephone number 'FX' for fax number 'EM' for Email address
GRP 3	ERC	1	C		APPLICATION ERROR INFORMATION	

1	2	3	4	5	6	7
	C901		M		APPLICATION ERROR DETAIL	
	9321		M	an..8	Application error	Application error code
	1131			an..3	Code list qualifier	n.a.
	3055			an..3	Code list responsible agency	n.a.
ERC	FTX	2	M		FREE TEXT	To communicate the reason for rejection
	4451		M	an..3	Text subject code qualifier	'AAO' for free text error description
	4453			an..3	Free text function code	n.a.
	C107				TEXT REFERENCE	
	4441			an..17	Free text identification	n.a.
	1131			an..3	Code list qualifier	n.a.
	3055			an..3	Code list responsible agency	n.a.
	C108		C		TEXT LITERAL	Text
	4440		M	an..70	Free text	Further description
	4440		C	an..70	Free text	Further description
	4440		C	an..70	Free text	Further description
	4440		C	an..70	Free text	Further description
	4440		C	an..70	Free text	Further description
	3453			an..3	Language, coded	n.a.

1	2	3	4	5	6	7
	4447			an..3	Text formatting, coded	n.a.
	UNT		M		MESSAGE TRAILER	End and control of completeness of the message
	0074		M	n..6	Number of segments in a message	
	0062		M	an..14	Message reference number	First 14 positions of the message reference number
	UNZ		M		INTERCHANGE TRAILER	End and control of the interchange
	0036		M	n..6	Interchange control count	'1' for number of messages contained in the interchange
	0020		M	an..14	Interchange control reference	First 14 positions of the message reference number

3. XML format of ERIRSP message

Both XSD and UN/EDIFACT formats of the ERIRSP message are functionally equivalent and share the same business rules.

In the ERIRSP message structure in UN/EDIFACT format, the column 'Description Qualifiers in quotation marks' indicates which information should be provided in a particular data element, including additional restrictions on size and allowed character set. In the XSD, these fill-in instructions are included in the 'xs:annotation' field of the respective data elements. This field also integrates a subfield 'xs:documentation' which indicates the corresponding field name of the UN/EDIFACT format. Besides, the instructions which are applicable for the UN/EDIFACT format are also applicable by default in the XSD. If additional information or deviating restrictions are required, it will be provided in this field.

The choice to use one or the other format is conditioned by the format of the original message. When a user sends an ERI message using XML format, he expects to receive an ERIRSP message using XML format in return, and vice versa, when he sends an ERI message using UN/EDIFACT format, he expects to receive an ERIRSP message using UN/EDIFACT format.

Appendix 1 XML format of ERIRSP message, XSD file (source code) (Distributed separately)

4. Error codes

For data attribute: MESSAGE **REFERENCE ANSWERED TO ERROR DESCR CODE**, the error codes defined in the tables 22-3, 22-4, 22-5 and 22-6 shall be used in segment ERC:

- Data element 9321 (EDIFACT).
- Data element <ErrorCode> (XML)

The purpose of the error codes is to inform the sender why a message has not been accepted or processed by the receiving party. The causes can be very diverse and cannot be always solved directly/indirectly by the sender. Despite this, it is important that a clear message is returned so that either the sender or the software supplier can determine the cause. The categories "Technical errors" and "Data invalid" are used when there is something wrong with the message structure/syntax/codes. When these error categories are returned, the sender should contact the supplier of the reporting software. The category "Invalid Reference Data" relates to the use of invalid reference data (see Annex 20 for the details of the reference data to be used). The last category is "Business violation" and is often related to invalid input or overwrite maximum dimensions, cones etc. Often the boatmaster can determine the cause of the error based on the subcategory returned.

- a) Presentation of the categories of codes
The codes are divided in four categories and subcategories

Table 22-2
Categories of codes

Code	Groups
1	Technical errors
2	Data invalid
3	Invalid Reference Data
4	Business violation

- b) Presentation of the subcategories of codes

Table 22-3
Subcategory 1

Code	Technical errors
101	Invalid Endpoint
102	XML format not respected or XSD not respected
104	Message not supported
105	Sender not Authorized
106	UN/EDIFACT format not respected
107	Invalid message version
108	Syntax version or level not supported
109	Character invalid as service character
110	Test indicator not supported
112	Invalid decimal notation
113	Invalid service character(s) (UN/EDIFACT format only)
114	Too many segment group repetitions (UN/EDIFACT format only)
199	Unspecified error

Table 22-4
Subcategory 2

Code	Data invalid
201	Message sequence invalid
202	Previous message not received
203	#PassengersOnBoard > #PersonsOnBoard
204	ETD >= ETA (for a voyage)
205	ETA >= ETD (for visiting a port)
206	Transport Mode not indicated
207	Transport Means not indicated
208	Navigation mode incorrect or not provided
209	Duplicate notification/request for vessel
210	Vessel tonnage exceed
299	Other error

Table 22-5
Subcategory 3

Code	Invalid Rerefence Data
301	Invalid Location information-code
302	Invalid Dangerous goods-code
303	Invalid Non-Dangerous goods-code
304	Invalid Vessel/Convoy-Type
305	Invalid Container-Type
399	Other

Table 22-6
Subcategory 4

Code	Business violation
403	Number of blue cones not indicated
410	Total convoy dimensions not allowed
415	Actual draught not allowed
419	Max. persons on board capacity exceeded
448	Maximum tonnage exceeded
470	Container-Type invalid or does not exist
475	Proper shipping name invalid or not indicated
476	No indication regarding an LNG system on-board
478	Actual aircraft not allowed
479	Actual length not allowed
480	Actual width not allowed
483	ENI number is invalid or not indicated
484	ENI number is not supported
485	IMO number invalid or not indicated
486	IMO number is not supported
487	Port of departure is invalid or not indicated
488	Next port of call is invalid or not indicated
489	Port of destination is invalid or not indicated
490	Port of loading is invalid or not indicated
491	Port of discharge is invalid or not indicated
492	Passage point is invalid or not indicated
493	Route point is invalid or not indicated
499	Other

ANNEX 23
BERTH MANAGEMENT PORT NOTIFICATION - BERMAN

TABLE OF CONTENTS

1. NECESSARY DATA IN ACCORDANCE WITH THE FAL CONVENTION 609
2. MESSAGE FUNCTION 610
3. MESSAGE STRUCTURE..... 611

1. Necessary data in accordance with the FAL convention

In the FAL General Declaration¹, public authorities shall not require more than the following information:

1. name and description of the ship
2. nationality of ship (country of the inspection body that issued the last vessel certificate)
3. particulars regarding registry
4. particulars regarding tonnage
5. name of boatmaster
6. name and address of ship's agent
7. brief description of cargo
8. number of crew
9. number of passengers
10. brief particulars of voyage
11. date and time of arrival, date of departure
12. port of arrival or departure
13. position of the ship in the port
14. the ships requirements in terms of waste and residue reception facilities
15. purpose of call

In addition the following particulars are to be included for ISPS² purposes:

16. name of the ships security officer
17. security certificate (ISSC) number and authority

1 IMO Compendium on facilitation and electronic business, FAL.5/Cic.35, 9 September 2011; referred to in the Annex to Directive 2010/65/EU of the European Parliament and of the Council of 20 October 2010 on reporting formalities for ships arriving in and/or departing from ports of the Member States and repealing Directive 2002/6/EC (OJ L 283, 29.10.2010, p. 1).

2 The International Ship and Port Facility Security Code (ISPS code) was adopted by the IMO in 2002; it is mandatory under the SOLAS Convention entering in force on 1 July 2004.

18. security level at which ship is operating level 1, 2 or 3
 19. information on number of persons and vehicles
2. Message function
- a) Functional definition

The BERMAN message is a message from a carrier, its agent or a vessel to the responsible port authority, requesting a berth, giving details of the call, vessel, berth requirements and expected operations¹. It is based on the EDIFACT BERMAN message as published in the UN/EDIFACT D 04B directory.
 - b) Field of application

The message is based on and supports the implementation by means of EDI of the following international and European legislation:

 - i) the IMO FAL Form 1 (as also contained in the IMO Compendium on Facilitation and electronic business, document FAL.5/Circ.15, dated 19 February 2001 and also contained in REF#EU-201065);
 - ii) International ship and port facility security (ISPS) code, adopted by the Conference of Contracting Governments of the International Maritime Organisation (IMO) on 12 December 2002, in the amendments to the annex to the International Convention of Safety of Life at Sea (SOLAS), 1974 and REF#EC-2004725.
 - c) Message principles

The following principles shall apply to the BERMAN message as defined in these technical specifications for the purpose of electronic ship reporting in inland navigation:

 1. A message shall contain information on only one means of transport/conveyance.
 2. One message shall relate to one visit of a ship to one port of call.
 3. The visit of the vessel shall be identified by a unique call reference number that is issued by or on behalf of the authority in the port (e.g. the port authority or the customs authority).
 4. The message shall incorporate the information related to applicable requirements regarding the notification of a ship to a port. It shall support one request for the ship — be it for entering the port, berthing on arrival of the ship, leaving the berth on departure of the ship or shifting of berths for the ship within the port or for only transiting through the port area.

¹ In accordance with the IMO Compendium, the BERMAN message can be used as a substitute for the IMO General Declaration (CUS- REP) for the purpose of the announcement of the expected arrival of a ship in a certain port.

5. The arrival notification shall contain all details regarding the movement of the ship from outside the port area to the first berth in the port area. The additional services to be arranged for arrival at the first berth (e.g. arrangement of pilots, VTS, tugboats, and linesmen) may be specified. The ETA (estimated time of arrival) at the entry point and previous port of call of the ship shall be given.
 6. A shift berthing request shall contain all details as to the movement from one berth to the next berth in the same port area. The additional services to be arranged (e.g. arrangement of tugboats, pilots or linesman) may be specified for each berth separately. The ETD (estimated time of departure) for the first berth is mandatory. The shift berthing request shall further contain the other berths that are planned to be visited during the ship's call, including the ETA at those berths.
 7. A departure request shall contain all details related to the departure of the ship from the (last) berth in the port area. Additional services to be arranged for departure from the berth (e.g. arrangement of tugboats, pilots or linesman) may be specified. The ETD from the berth and the next port of call of the ship shall be given upon departure.
 8. The message shall cater for the provision of sending a replacement or a cancellation of a previously sent original message.
 9. The message content shall be uniquely identified by means of the message reference (in BGM 1004) and the message sender identification (in NAD(MS) 3039). All other identifying data, such as the unique ship ID of the ship or the voyage number, are secondary references. The sending of replacements and updates also makes use of this principle.
3. Message structure
- a) Segment index (alphabetical sequence by tag)
 - BGM Beginning of message
 - COM Communication contact
 - CTA Contact information
 - DTM Date/time/period
 - FTX Free text
 - GDS Nature of cargo
 - HAN Handling instructions
 - LOC Place/location identification
 - MEA Measurements
 - NAD Name and address

POC Purpose of call
 QTY Quantity
 RFF Reference
 TDT Transport information
 TSR Transport service requirements
 UNH Message header
 UNT Message Trailer

b) Segment table

Pos	Tag	Name	S	R
	UNA		C	1
	UNB		M	1
0010	UNH	Message header	M	1
0020	BGM	Beginning of message	M	1
0030	DTM	Date/time/period	M	1
0040	FTX	Free text	C	1
0050	RFF	Reference	C	9
0070		Segment Group 1	M	4
0080	NAD	Name and address	M	1
0090		Segment Group 2	C	1
0100	CTA	Contact information	M	1
0110	COM	Communication contact	C	4
0120		Segment Group 3	M	1
0130	TDT	Transport information	M	1
0140	RFF	Reference	C	2
0150	DTM	Date/time/period	C	1
0160	MEA	Measurements	C	7
0170	FTX	Free text	C	9
0190		Segment Group 4	M	5
0200	LOC	Place/location identification	M	1

Pos	Tag	Name	S	R
0210	DTM	Date/time/period	M	1
0300		Segment Group 7	M	9
0310	TSR	Transport service requirements	M	1
0320	QTY	Quantity	C	3
0340		Segment Group 8	M	9
0350	LOC	Place/location identification	M	1
0370	DTM	Date/time/period	C	1
0380	QTY	Quantity	C	2
0390	POC	Purpose of call	C	9
0400	FTX	Free text	C	1
0410		Segment Group 9: HAN	C	8
0420	HAN	Handling instructions	M	1
0440		Segment Group 10: GDS	C	9
0450	GDS	Nature of cargo	M	1
0470	MEA	Measurements	C	1
0500	UNT	Message Trailer	M	1

c) Branching diagram

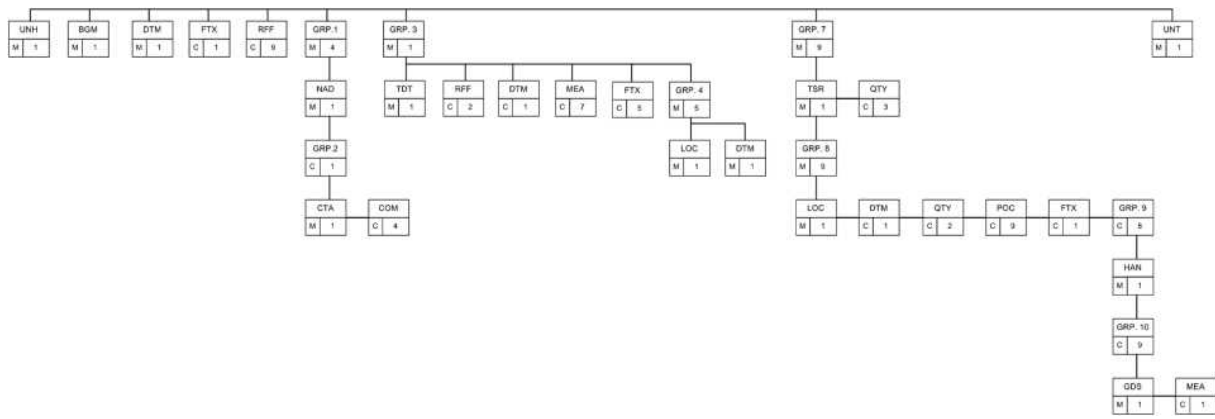

The pre-arrival notification message format for the berth management message is as follows:

Segment Group	Segment Composite data element (C) Data element TAG	Level	Status	Format	Name	Description Qualifiers in quotation marks
1	2	3	4	5	6	7
	UNA		C		SERVICE STRING ADVICE	
			M	an1	Component data element separator	:
			M	an1	Segment tag and data element separator	+
			M	an1	Decimal notation	.
			M	an1	Release indicator	?
			M	an1	Reserved future use	<i>Space</i>
			M	an1	Segment terminator	'
					<i>Advised string: UNA:+.? '</i>	<i>6 characters</i>
	UNB		M		INTERCHANGE HEADER	
	S001		M		SYNTAX IDENTIFIER	
	0001		M	a4	Syntax identifier	'UNOC' Controlling agency
	0002		M	n1	Syntax version number	'2'
	S002		M		INTERCHANGE SENDER	

1	2	3	4	5	6	7
	0004		M	an..35 (an25)	Sender identification	Mailbox number or unique name or the unique identifier of a RIS-centre or traffic post
	0007			an..4	Partner identification code qualifier	n.a.
	0008			an..14	Address for reverse routing	n.a.
	S003		M		INTERCHANGE RECIPIENT	
	0010		M	an..35 (an25)	Recipient identification	Mailbox number or unique name or the unique identifier of a RIS-centre or traffic post
	0007		C	an..4	Partner identification code qualifier	n.a.
	0014		C	an..14	Routing address	n.a.
	S004		M		DATE/TIME OF PREPARATION	
	0017		M	n6	Date	Generation date, YYMMDD
	0019		M	n4	Time	Generation time, HHMM
	0020		M	an..14	Interchange reference identification	First 14 positions of the message reference number
	S005		C		RECIPIENTS REFERENCE, PASSWORD	n.a.
	0022			an..14	Recipient's reference/password	n.a.
	0025			an2	Recipient's reference, password qualifier	n.a.
	0026			an..14	Application reference	n.a.
	0029			a1	Processing priority code	n.a.
	0031		C	n1	Acknowledgement request	'1' = Sender requests acknowledgement, i.e. UNB and UNZ segments received and identified

1	2	3	4	5	6	7
	0032			an..35	Communications agreement id	n.a.
	0035			C	Test indicator	Test indicator '1' = the interchange relates to a test message
	UNH		M		IDENTIFICATION, SPECIFICATION AND HEADING OF A MESSAGE	
	0062		M	an..14	Message reference number	First 14 positions of the message number
	S009		M		MESSAGE IDENTIFIER	Message identification
		0065	M	an..6	Message type	'BERMAN', message type
		0052	M	an..3	Message version number	'D', message version number
		0054	M	an..3	Message release number	'05B', message release number
		0051	M	an..2	Controlling agency	'UN', controlling agency
		0057	M	an..6	Association assigned code	'ERI14', ERI version 1.4
		0068	C	an..35	Common access reference	Reference to all messages related to one common file
	S010				STATUS OF THE TRANSFER	
		0070		n..2	Sequence of transfers	n.a.
		0073		a1	First and last transfer	n.a.
	BGM		M		BEGINNING OF MESSAGE	Identification of the type and function of the message

1	2	3	4	5	6	7
	C002				DOCUMENT/MESSAGE NAME	
	1001		M	an..3	Document/message name code	<p>Message Type:</p> <p>'22' = Final transmission (End of voyage)</p> <p>'23' Status information Information regarding the status of a related message.</p> <p>'185' Conveyance declaration (arrival) Declaration to the public authority upon arrival of the conveyance.</p> <p>'186' Conveyance declaration (departure) Declaration to the public authority upon departure of the conveyance.</p> <p>'187' Conveyance declaration (combined) Combined declaration of arrival and departure to the public authority.</p> <p>'318' Application for shifting from the designated place in port Document to apply for shifting from the designated place in port.</p> <p>'282' Modification of existing message Requesting a change to an existing message.</p> <p><i>Note: '187' to be used as continued voyage indicator</i></p>
	1131			an..17	Code list qualifier	n.a.
	3055			an..3	Code list responsible agency	n.a.
	1000			an..35	Document/message name	n.a.
	C106		M		DOCUMENT/MESSAGE IDENTIFICATION	
	1004		M	an..35	Document identifier	Use max. (an15) for message reference number

1	2	3	4	5	6	7
	1056			an..9	Version	
	1060			an..6	Revision number	
	1225		M	an..3	Message function code	Function of message: '9' = new message, original '5' = modification message by replacement '1' = cancellation '22' = Final transmission (End of voyage) '150' = Interruption of voyage' '151' = Restart of voyage
	4343			an..3	Response type code	'QA'
	DTM		M		DATE/TIME/PERIOD	
	C507		M		DATE/TIME/PERIOD	
	2005		M	an..3	Date or time or period function code qualifier	'137' Date of preparation
	2380		M	an..35	Date or time period value	Date: CCYMMDD
	2379		M	an..3	Date or time or period format code	'102' For CCYMMDDHHMM use '203'
	FTX		C		FREE TEXT	
	4451		M	an..3	Text subject code qualifier	'CHG' = Change information

1	2	3	4	5	6	7
	4453			an..3	Free text function code	n.a.
	C107				TEXT REFERENCE	
	4441		C	an..17	Free text identification	General information on the call of the vessel 'CAM' = mistakes in previous message 'CAN' = cancelled because of cargo change 'GIV' = General info vessel
	1131			an..17	Code list qualifier	n.a.
	3055			an..3	Code list responsible agency	n.a.
	C108		C			
	4440		C	an..512	Free text	Free text: Vessel defects info (vessel, nautical equipment, cargo handling, protruding parts, fire, overheating, smoke)
	4440			an..512	Free text	n.a.
	4440			an..512	Free text	n.a.
	4440			an..512	Free text	n.a.
	4440			an..512	Free text	n.a.
	3453			an..3	Language, coded	n.a.
	4447			an..3	Text formatting, coded	n.a.

1	2	3	4	5	6	7
	RFF		C		REFERENCE	Reference to the message which is changed, mandatory if the message is a modification message
	C506		M		REFERENCE	
	1153		M	an..3	Reference qualifier	'ACW' Reference to previous message
	1154		M	an..70	Reference number	Use (an15) message reference number of the BGM, tag 1004 of the message this current message refers to
	1156			an..6	Line number	n.a.
	4000			an..35	Reference version number	n.a.
	1060			an..6	Revision number	n.a.
	RFF		C		REFERENCE	Reference information
	C506		M		REFERENCE	Only if known
	1153		M	an..3	Reference qualifier	'ATZ' Ship's stay reference number 'GDN' General Declaration number 'AAE' Goods declaration number
	1154		M	an..70	Reference identifier	Reference number or declaration number
	1156			an..6	Line number	n.a.
	4000			an..35	Reference version number	n.a.
	1060			an..6	Revision number	n.a.

1	2	3	4	5	6	7
	RFF		C		REFERENCE	REFERENCE INFORMATION
	C506		M		REFERENCE	
	1153		M	an..3	Reference qualifier	'EPC' = Electronic port clearance (single window) 'ACE' Related document number 'EPC' Referenced document is sent via EDI and an EPC application 'ROB' Referenced document is available but remains on board
	1154		M	an..70	Reference identifier	'799' Ship's stores declaration '797' Maritime declaration of health '745' Passenger list '744' Crew's effects declaration '250' Crew list declaration '85' Cargo declaration
	1156			an..6	Line number	n.a.
	4000			an..35	Reference version number	n.a.
	1060			an..6	Revision number	n.a.
<i>NAD Gr 1</i>	NAD		M		Name and address	

1	2	3	4	5	6	7
	3035		M	an..3	Party function code qualifier	Sender, carrier's agent and/or boatmaster are mandatory Name type: 'MS' Message sender 'CG' Carrier's agent 'CPE' Boatmaster 'AM' Authorised official (security officer)
	C082		C		PARTY IDENTIFICATION DETAILS	Code if known at receiver, otherwise other fields
	3039		M	an..35	Party identification	EAN number
	1131			an..17	Code list qualifier	n.a
	3055			an..3	Code list responsible agency	n.a
	C058				NAME AND ADDRESS	n.a.
	3124			an..35	Name and address line	n.a.
	3124			an..35	Name and address line	n.a.
	3124			an..35	Name and address line	n.a.
	3124			an..35	Name and address line	n.a.
	3124			an..35	Name and address line	n.a.
	C080				PARTY NAME	n.a.
	3036			an..35	Party name	n.a.
	3036			an..35	Party name	n.a.
	3036			an..35	Party name	n.a.

1	2	3	4	5	6	7
	3036			an..35	Party name	n.a.
	3036			an..35	Party name	n.a.
	3045			an..3	Party name format, coded	n.a.
	C059				STREET	n.a.
	3042			an..35	Street and number/PO box	n.a.
	3042			an..35	Street and number/PO box	n.a.
	3042			an..35	Street and number/PO box	n.a.
	3042			an..35	Street and number/PO box	n.a.
	3164			an..35	City Name	n.a.
	C819				Country sub-entity details	n.a.
	3229			an..9	n.a.	n.a.
	1132			an..17	n.a.	n.a.
	3055			an..3	n.a.	n.a.
	3228			an..70	n.a.	n.a.
	3251		C	an..17	Postcode identification	Postal identification code
	3207		C	an..3	Country	REF#ISO-3166-1 two digit alpha country code, see Part IV, Article 2.03(8)
<i>NAD Gr 2</i>	CTA		M	NAD	CONTACT INFORMATION	Sender contact details

1	2	3	4	5	6	7
	3139		M	an..3	Contact function	'IC' = Information contact
	C056				DEPARTMENT OR EMPLOYEE DETAILS	
		3413		an..17	Department or employee identification	n.a.
		3412	C	an..35	Department or employee	Contact person, name or function
CTA	COM		C	NAD/ CTA	COMMUNICATION CONTACT	Sender communication contact details
	C076				COMMUNICATION CONTACT	
		3148	M	an..512	Communication number	Communication number
		3155	M	an..3	Communication channel qualifier	'TE' for telephone number 'FX' for fax number 'EM' for email address 'EI' for EDI mailbox number (EDI number or email address for NAD 1 is mandatory if a response in the form of an APERAK message is requested for. If no response is requested, the EDI number and email address is not to be used).
TDT Gr 3	TDT		M		TRANSPORT INFORMATION	Specification of the means of transport, <i>the naming vessel within a convoy</i> (a single vessel without barge is also a convoy in this context)
		8051	M	an..3	Transport stage code qualifier	'20' for main carriage transport

1	2	3	4	5	6	7
	8028		M	an..17	Conveyance reference number	Voyage number, defined by sender of the message
	C220		M		MODE OF TRANSPORT	
	8067		M	an..3	Mode of transport, coded	'8' for inland water transport '1' for maritime transport see REF#UNECE-R19
	8066			an..17	Mode of transport	n.a.
	C228		M		TRANSPORT MEANS	
	8179		M	an..8	Type of means of transport identification, convoy type	Code for ship and convoy types of means of transport from UN/CEFACT Rec. 28, see Part IV, Article 2.03(1)
	8178			an..17	Type of means of transport	n.a.
	C040				CARRIER	n.a.
	3127			an..17	Carrier identification	n.a.
	1131			an..17	Code list qualifier	n.a.
	3055			an..3	Code list responsible agency	n.a.
	3128			an..35	Carrier name	n.a.
	8101			an..3	Transit direction, coded	n.a.
	C401				EXCESS TRANSPORTATION INFORMATION	
	8457			an..3	Excess transportation reason	n.a.
	8459			an..3	Excess transportation responsibility	n.a.

1	2	3	4	5	6	7
	7130			an..17	Customer authorization number	n.a.
	C222		M		TRANSPORT IDENTIFICATION	
	8213		M	an..9 (an7..8)	ID. of means of transport identification	<i>Vessel number</i> : 7 digits for IMO indication, 8 digits for unique European vessel identification number (ENI)
	1131			an..17	Code list qualifier	'IMO' for an IMO number, see Part IV, Article 2.03(2) 'ENI' for a unique European vessel identification number, see Part IV, Article 2.03(3)
	3055			an..3	Code list responsible agency	n.a.
	8212		M	an..35	ID of the means of transport	<i>Name of the ship</i> . If the name results in more than 35 positions, the name of the vessel is shortened.
	8453		M	an..3	Nationality of means of transport	REF#ISO-3166-1 two-alpha country code see Part IV, Article 2.03(8). If the nationality of the means of transport is not known, the 3 digit code of the country of the inspection body that issued the last vessel certificate shall be used.
	8281			an..3	Transport ownership	n.a.
TDT	RFF		C	TDT	REFERENCE	
	C506		M		REFERENCE	
	1153		M	an..3	Reference qualifier	'VM' Vessel identification 'PEX' Pilotage exemption number

1	2	3	4	5	6	7
	1154		M	an..70	Reference number	Radio call sign if applicable or the identity of each barge/ vessel in a combination (ERI ID) Number of exemption
	1156			an..6	Line number	n.a.
	4000			an..35	Reference version number	n.a.
	1060			an..6	Revision number	n.a.
TDT	DTM		C	TDT	DATE/TIME/PERIOD	
	C507		M		DATE/TIME/PERIOD	
	2005		M	an..3	Date or time or period function code qualifier	Local time at the place of arrival Code '132' = ETA
	2380		M	an..35	Date or time period value	Date/time: CCYYMMDDHHMM
	2379		M	an..3	Date or time or period format code	'203'
TDT	MEA		C	TDT	MEASUREMENTS	
	6311		M	an..3	Measurement purpose qualifier	Measurement application qualifier: 'AAE' Measurement
	C502		M		MEASUREMENT DETAILS	

1	2	3	4	5	6	7
	6313		M	an..3	Property measured	Measurement dimension: 'AAM' Gross tonnage of vessel, BT 'AAN' Net tonnage of vessel 'ACS' Length overall, 'ADS' Length bow to bridge 'WM' Width, maximum 'DP' Draft, maximum (depth) 'HM' Height maximum above the water (air draft)
	6321			an..3	Measurement significance	n.a.
	6155			an..17	Measurement attribute identification	n.a.
	6154			an..70	Measurement attribute	n.a.
	C174		M		VALUE/RANGE	
	6411		M	an..3	Measurement unit qualifier	Measure unit qualifier: 'TNE' Metric tons 'CMT' Centimetre 'MTR' Metre
	6314		M	n..18	Measurement value	
	6162			n..18	Range minimum	n.a.
	6152			n..18	Range maximum	n.a.
	6432			n..2	Significant digits	n.a.
	7383			an..3	Surface/layer indicator	n.a.

1	2	3	4	5	6	7
<i>TUT</i>	FTX		C	TDT	FREE TEXT	
	4451		M	an..3	Text subject code qualifier	General subject indicator Text subject type 'ACB' Additional information 'AFJ' Defect description 'HAZ' Hazardous 'AAA' General goods description 'WAS' Waste reporting 'VES' vessel particulars
	4453		C	an..3	Free text function code	If text subject is ACB, WAS, AAA or AFJ, here the dangerous goods can be indicated through: 'DGN' = No dangerous goods 'DGY' = Dangerous goods on board
	C107		C		TEXT REFERENCE	

1	2	3	4	5	6	7
	4441		C	an..17	Free text identification	'WEX' = Waste report exempt for 'WAS' 'CGS' = Cargo is gassed for 'ACB' For 'HAZ': Co0 = 0 Cone Co1 = 1 Cones Co2 = 2 Cones Co3 = 3 Cones 'B' = Red Flag (B) for IMO 'V' special permit
	1131			an..17	Code list qualifier	n.a.
	3055			an..3	Code list responsible agency	n.a.
	C108		M			
	4440		C	an..512	Free text	Text description of defects such as AIS, Navigation equipment radar, engine, rudder, etc.
	4440			an..512	Free text	n.a.
	4440			an..512	Free text	n.a.
	4440			an..512	Free text	n.a.
	4440			an..512	Free text	n.a.
	3453			an..3	Language, coded	n.a.
	4447			an..3	Text formatting, coded	n.a.

1	2	3	4	5	6	7
<i>TDT GR 4</i>	LOC		M	TDT	PLACE/LOCATION IDENTIFICATION	Port.
	3227		M	an..3	Place/location qualifier	Place/location qualifier: '5' Place of departure '94' Previous of port of call '61' Next port of call '89' Place of registration '153' Port of call
	C517		M		LOCATION IDENTIFICATION	
		3225	M	an..25 (an5)	Place/location identification	REF#UNECE-R16 location code of the port, see Part IV, Article 2.03(9)
		1131		an..17	Code list qualifier	n.a.
		3055		an..3	Code list responsible agency	n.a.
		3224	C	an..256	Place/location	Full name of the port
	C519		C		RELATED LOCATION ONE IDENTIFICATION	
		3223	M	an..25 (an..5)	Related place/location one identification	Terminal code, see Part IV, Article 2.03(11)
		1131		an..17	Code list qualifier	n.a.
		3055		an..3	Code list responsible agency	n.a.
		3222	D[Use 1]	an..70 (an..17)	Related place/location one	Full name of the terminal

1	2	3	4	5	6	7
	C553		C		RELATED LOCATION TWO IDENTIFICATION	
	3233		C	an..25 (an..5)	Related place/location two identification	Fairway section code, see Part IV, Article 2.03(10)
	1131			an..17	Code list qualifier	
	3055			an..3	Code list responsible agency	n.a.
	3232		C	an..70 (an..5)	Related place/location two	Fairway section hectometre
	5479			an..3	Relation	n.a.
	DTM		C	TDT/LOC	DATE/TIME/PERIOD	Required if place of registration is given
	C507		M		DATE/TIME/PERIOD	
	2005		M	an..3	Date or time or period function code qualifier	'259' Registration date
	2380		M	an..35	Date or time period value	Date: CCYMMDD
	2379		M	an..3	Date or time or period format code	'102' date format
<i>TSR Gr 7</i>	TSR		M		Transport service requirements	
	C536				Contract and carriage condition	n.a.
	4065			an..3	Contract and carriage condition code	n.a.
	1131			an..17	Code list identification code	n.a.

1	2	3	4	5	6	7
	3055			an..3	Code list responsible agency code	n.a.
	C233		M		Service	
	7273		M	an..3	Service requirement code	Service requirement: 'BER' Request for mooring service at a berth 'PIL' Request for pilot service 'VTS' Request for Vessel Traffic Services 'TUG' Request for tugboat service 'MAR' Planned handling of MARPOL substances 'SEC' Security services
	1131			an..17	Code list identification code	n.a.
	3055			an..3	Code list responsible agency code	n.a.
	7273			an..3	Service requirement code	n.a.
	1131			an..17	Code list identification code	n.a.
	3055			an..3	Code list responsible agency code	n.a.
	C537				Transport priority	
	4219			an..3	Transport service priority code	n.a.
	1131			an..17	Code list identification code	n.a.
	3055			an..3	Code list responsible agency code	n.a.
	C703				Nature of cargo	
	7085			an..3	Cargo type classification code	n.a.

1	2	3	4	5	6	7
	1131			an..17	Code list identification code	n.a.
	3055			an..3	Code list responsible agency code	n.a.
<i>TSR</i>	QTY		C	TSR/QTY	QUANTITY	To indicate the number of crew, passengers and others such as pets or other animals
	C186		M		Quantity details	
	6063		M	an..3	Quantity type code qualifier	'115' = Total number of crew on board including the boatmaster '114' = Total number of people on board '14' = Total number of animals on board
	6060		M	an...35	Quantity	Number e.g. 4
	6411		C	an..8	Measure unit code	n.a.
<i>TSR Gr 8</i>	LOC		M	TSR	PLACE/LOCATION IDENTIFICATION	Port
	3227		M	an..3	Place/location qualifier	Place/location qualifier: '5' Place of departure '94' Previous of port of call '61' Next port of call '89' Place of registration '153' Port of call
	C517		M		LOCATION IDENTIFICATION	

1	2	3	4	5	6	7
	3225		M	an..25 (an5)	Place/location identification	REF#UNECE-R16 location code of the port, see Part IV, Article 2.03(9)
	1131			an..17	Code list qualifier	n.a.
	3055			an..3	Code list responsible agency	n.a.
	3224		C	an..256 (an..17)	Place/location	Full name of the port location
	C519		C		RELATED LOCATION ONE IDENTIFICATION	
	3223		M	an..25 (an..5)	Related place/location one identification	Terminal code, see Part IV, Article 2.03(11)
	1131			an..17	Code list qualifier	n.a.
	3055			an..3	Code list responsible agency	n.a.
	3222		D[Use 1]	an..70 (an..35)	Related place/location one	Full name of the terminal
	C553		C		RELATED LOCATION TWO IDENTIFICATION	
	3233		M	an..25 (an..5)	Related place/location two identification	Fairway section code, see Part IV, Article 2.03(10)
	1131			an..17	Code list qualifier	
	3055			an..3	Code list responsible agency	n.a.
	3232		C	an..70 (an..5)	Related place/location two	Fairway section hectometre
	5479			an..3	Relation	n.a.

1	2	3	4	5	6	7
<i>Gr 8</i>	DTM		C	TSR/LOC	DATE/TIME/PERIOD	Date and time of the start of the transport service requirement
	C507		M		DATE/TIME/PERIOD	
	2005		M	an..3	Date or time or period function code qualifier	'132' Arrival date/time, estimated
	2380		M	an..35	Date or time period value	Time: CCYYMMDDHHMM
	2379		M	an..3	Date or time or period format code	'203'
<i>Gr 8</i>	QTY		C	TSR/LOC	QUANTITY	
	C186		M		Quantity details	Quantity details
	6063		M	an..3	Quantity type code qualifier:	Quantity type code qualifier: '1' Discrete quantity
	6060		M	an..35	Quantity	Number of tugboats required Number of linesman
	6411			an..3	Measurement unit code	n.a.
<i>Gr 8</i>	POC		M	TSR	PURPOSE OF CALL	
	C525		M		Purpose of conveyance call	Purpose of conveyance call

1	2	3	4	5	6	7
	8025		M	an..3	Conveyance call purpose description code	'1' Cargo operation '2' Passenger movement '3' Taking bunkers '4' Changing crew '5' Goodwill visit '6' Taking supplies '7' Repair '8' Laid-up '9' Awaiting orders '10' Miscellaneous '11' Crew movement '12' Cruise, leisure and recreation '13' This is a visit to a port which has been ordered by government '14' Quarantine inspection '15' Refuge '16' Tank cleaning '17' Waste disposal
	1131			an..17	Code list identification code	n.a.
	3055			an..3	Code list responsible agency code	n.a.
	8024			an..35	Conveyance call purpose description	n.a.
Gr 8	FTX		C	TSR/LOC	FREE TEXT	Only to be used for security information

1	2	3	4	5	6	7
	4451		M	an..3	Text subject code qualifier	The security information may be given in 4441 'SEC' Current security information
	4453			an..3	Free text function code	n.a.
	C107		M		TEXT REFERENCE	
	4441		M	an..17	Free text identification	Level of security S1 Security level 1 S2 Security level 2 S3 Security level 3
	1131			an..17	Code list qualifier	n.a.
	3055			an..3	Code list responsible agency	n.a.
	C108		M			
	4440		M	an..512	Free text	Further remarks 'PER' followed by the number of persons on board.
	4440		C	an..512	Free text	ISSC information 'SCN' Security certificate not available 'SCY' Security certificate on board
	4440		C	an..512	Free text	Here the brand of the car and licence plate number can be given 'CAR' licence number
	4440		C	an..512	Free text	Free text: Name of the service provider requested for in the TSR segment

1	2	3	4	5	6	7
	4440			an..512	Free text	n.a.
	3453			an..3	Language, coded	n.a.
	4447			an..3	Text formatting, coded	n.a.
<i>LOC Gr 9</i>	HAN		C	TSR/LOC	HANDLING INSTRUCTIONS	
	C524		M		HANDLING INSTRUCTIONS	Handling instructions
	4079		M	an..3	Handling instructions, coded	Handling instructions coded: 'LLO' 'LOA' = Loading 'LDI' 'DIS' = Discharge 'RES' 'RES' = Re-stow 'T' 'TRA' = Transit 'TSP' 'CTC' = Cargo tank cleaning 'BUN' 'BUN' = Bunkering only 'DRY' 'RED' = Repairs in dry-dock 'WET' 'REW' = Repairs in wet-dock 'NCO' = No cargo operation
	1131			an..17	Code list qualifier	n.a.
	3055			an..3	Code list responsible agency, coded	n.a.
	4078		C	an..70	Handling instructions	Bolder numbers, preferred side for berthing, pilot embarkation point, MFO, MDF, fresh water, etc.
	C218				HAZARDOUS MATERIAL	

1	2	3	4	5	6	7
	7419			an..7	Hazardous material class code, identification	n.a.
	1131			an..17	Code list qualifier	n.a.
	3055			an..3	Code list responsible agency coded	n.a.
	7418			an..35	Hazardous material class	n.a.
<i>HAN Gr 10</i>	GDS		M	TSR/LOC /HAN	NATURE OF CARGO	
	C703		M		Nature of cargo	

1	2	3	4	5	6	7
	7085		M	an..3	Cargo type classification code	Nature '5' Other non-containerised '6' Vehicles '7' Roll-on roll-off '8' Palletised '9' Containerised '10' Break bulk '11' Hazardous cargo '12' General cargo '13' Liquid cargo '14' Temperature controlled cargo '15' Environmental pollutant cargo '16' Not-hazardous cargo '17' Diplomatic '18' Military '19' Obnoxious '21' Household goods '22' Frozen cargo '30' Cargo in bulk (sand, gravel, ore, etc.)
	1131			an..17	Code list identification code.	n.a.
	3055			an..3	Code list responsible agency, coded	n.a.

1	2	3	4	5	6	7
	MEA		C	TSR/LOC /HAN/ GDS	MEASUREMENTS	
	6311		M	an..3	Measurement purpose qualifier	Measurement application qualifier: 'AAE' Measurement
	C502		M		MEASUREMENT DETAILS	Measurement details
	6313		M	an..3	Property measured	Measurement dimension: 'G' Gross weight
	6321			an..3	Measurement significance	n.a.
	6155			an..17	Measurement attribute identification	n.a.
	6154			an..70	Measurement attribute	n.a.
	C174		M		VALUE/RANGE	
	6411		M	an..3	Measurement unit qualifier	Measure unit qualifier: 'KGM' Kilogram 'TNE' Metric tons
	6314		M	n..18	Measurement value	Weight
	6162			n..18	Range minimum	n.a.
	6152			n..18	Range maximum	n.a.
	6432			n..2	Significant digits	n.a.
	7383			an..3	Surface/layer indicator	

1	2	3	4	5	6	7
	UNT		M		MESSAGE TRAILER	End and control of completeness of the message
	0074		M	n..10	Number of segments in a message	
	0062		M	an..14	Message reference number	First 14 positions of the message reference number
	UNZ		M		INTERCHANGE TRAILER	End and control of the interchange
	0036		M	n..6	Interchange control count	'1' for number of messages contained in the interchange
	0020		M	an..14	Interchange control reference	First 14 positions of the message reference number

Business rules	
D[USE 1]	If the code is XXXXX, then this data-element shall be completed.

ANNEX 24
VOYAGE PLAN NOTIFICATION - ERIVROY

TABLE OF CONTENTS

- 1. INTRODUCTION 649**
 - 1.1 Objective of the message 649
 - 1.2 Functional definition 649
 - 1.3 Message principles 649
 - 1.4 Necessary data in accordance with the user requirements 650
- 2. XML FORMAT OF ERIVROY MESSAGE 651**

1. Introduction

1.1 Objective of the message

In line with the developments in inland navigation to increasingly use Information and Communication Technologies (ICT) for the exchange of data with authorities and partners, the standardised message for voyage plan notification, ERIVROY is meant to be used as a message type from a carrier, its agent or a vessel to the responsible waterway authorities and where applicable involved commercial parties or between the waterway authorities mutually, reporting a voyage plan and its particulars and giving details of the voyage, vessel, intended voyage details and expected passage of waypoints and other key passage points. It is meant to provide a transport route schedule of a certain vessel and its voyage.

The advance availability of routing information will make communication with the involved parties such as the waterway authorities easier and will facilitate handling of certain requests and will ensure easier and safer passages of locks, bridges or of other events that could impact the planification of the voyage. In this way a better planning of a voyage is feasible. In the event of changes or disaster, planning becomes easier and vessel traffic services and management are facilitated. In that way using this message increases the performance and reliability during the voyage of a vessel or a convoy.

1.2 Functional definition

The functional definition of the ERIVROY message is as follows:

Send a notification message as described in the “objective of the message”

Request an update of the message and send the answer to this request.

- A waterway authority can inform the boatmaster if the time-difference between the calculation of the boatmaster significantly differs of the calculation by the authority(ies)

1.3 Message principles

The following principles are applicable to the voyage plan message:

- a) The function of this message is to provide a transport route schedule of a certain vessel.
- b) One message relates to one voyage plan.
- c) The message incorporates the legal requirements regarding the notification of the planned voyage of a vessel to the waterway authorities.
- d) The voyage plan contains all details regarding the (planned) movement of the vessel from the place of departure to the place of arrival at the first berth in the port area. More than one destination will be possible (in case of two or more ports as destination of a journey). Preferably a new updated voyage plan will be created after the arrival at a port or the first port of a journey.

- e) The responsibility for the definition of a waypoint lies primarily with the sender of the message so primarily the boatmaster. It is possible to define less waypoints to be mandatory for voyages of a long distance. The carrier, its agent or the boatmaster will declare the ETA for those waypoints on a voyage which are considered essential to ensure a good overview of the chosen route.
- f) A message update should be sent in case of an unexpected (long) waiting time e.g. at one lock.
- g) The information related to ETA at certain waypoints and key points such as movable bridges, locks and other essential passage points of the vessel are mandatory datafields in the message. This ETA may be estimated through a period of time (time span) that the vessel is to be expected at a certain point. This can be considered as the timespan between the first possible arrival time and last possibility of arrival.
- h) The voyage status information will be reported in addition to other reporting messages whereby the repetition of the same data will be avoided wherever possible.
- i) The ETD from the berth and the next port of call of the vessel is mandatory information if the message is sent before departure of the vessel.
- j) The message caters for the provision of sending a Replacement, Modification, Status update or a cancellation of a previously sent original message.

1.4 Necessary data in accordance with the user requirements

In accordance with the user requirements for the ERI voyage plan message the following information is required:

- a) Name of the vessel
- b) Type of vessel (see REF#UNECE-R28)
- c) Unique vessel identification number
- d) Nationality (country of the inspection body that issued the last vessel certificate)
- e) Voyage plan status
- f) Name of boatmaster
- g) Length and width of the vessel
- h) Length and width of the convoy (including possible oversize cargo)
According to experience gained it is important to provide information about the dimensions of a convoy as a whole. This can be done best by providing the maximum length and the maximum width. This information is essential for lock planning in particular.
- i) Draught
- j) Air draught (highest point of vessel or convoy above the waterlevel)
- k) Average estimated speed over ground for a certain voyage (cruising speed)
- l) Origin of the voyage (Place of departure)
- m) Voyage destination in compliance with the voyage definition
- n) Date / time of departure (estimated and actual)
- o) Start of daily navigation
- p) End of daily navigation

- q) Preference for passing locks or bridges on demand
A boatmaster may specify its preference regarding how to pass objects along his voyage, with the 3 following possibilities:
Normal: he only wants to pass locks or bridges on regular opening hours
All Free: he wants to pass locks or bridges on regular opening hours and “on demand” but only when this is free of charge
All: he wants to pass locks or bridges on regular opening hours and “on demand” even if he has to pay on call
- r) Waypoints (key passage points)
- s) ETA waypoints (including estimated passage time of border) or where applicable the period through 2379 code 713 = YYMMDDHHMM - YYMMDDHHMM
- t) ETD waypoints (where required estimated period of time = YYMMDDHHMM – YYMMDDHHMM in actual message without hyphen).
- u) ATA waypoints (including actual passage time of border)
- v) ATD waypoints
- w) Other relevant information for the calculation of the voyage
It is possible to specify here any additional relevant information that can be useful for the calculation of the voyage.
- x) Number of persons on board
- y) Brief description of cargo.

2. XML format of ERIVROY message

The Voyage Plan Notification (ERIVROY) can be used using XML formatting.

Appendix 1 XML format of ERIVROY message, XSD file (source code) (Distributed separately)

***ANNEX 25
(LEFT VOID)***

***ANNEX 26
(LEFT VOID)***

***ANNEX 27
(LEFT VOID)***

European Committee for drawing up Standards in the field of Inland Navigation
(CESNI)

Edition 2025/1

**EUROPEAN STANDARD FOR RIVER INFORMATION SERVICES
ANNEXES**

Annexes 28 to 32

ANNEX 28
NOTICES TO SKIPPERS ENCODING GUIDE FOR EDITORS

TABLE OF CONTENTS

1.	BACKGROUND AND STRUCTURE.....	664
2.	APPLICABILITY OF NTS MESSAGES	664
3.	SELECTION OF THE NTS MESSAGE TYPE	665
4.	FTM BASIC CONSIDERATIONS, STEPS TOWARDS PUBLICATION OF AN FTM	665
5.	FTM EXPLANATION OF CODES	670
6.	WRM BASIC CONSIDERATIONS	678
7.	ICE RELATED MESSAGES BASIC CONSIDERATIONS, STEPS TOWARDS PUBLICATION OF AN ICE MESSAGE	678
8.	WERM BASIC CONSIDERATIONS.....	680
9.	RULES FOR CERTAIN ELEMENTS.....	680

Abbreviations

Abbreviation	Meaning
CEVNI	European Code for Inland Waterways (http://www.unece.org/trans/main/sc3/sc3res.html)
ENC	Electronic Navigational Chart
FTM	Fairway and Traffic related Message
Inland ECDIS	Inland Electronic Chart Display and Information System
ISRS Location Code	"International Ship Reporting Standard" Location Code
NtS	Notices to Skippers
RIS	River Information Services
VHF	Very High Frequency
WERM	Weather Related Message
WRM	Water Related Message
WSDL	Web Services Description Language
XSD	XML Schema Definition

1. Background and Structure

ES-RIS is continuously being improved. A major step forward was the release of the NtS web service facilitating exchange of NtS messages between authorities as well as between authorities and NtS users.

Two documents have been developed to facilitate the harmonised encoding of NtS messages nationally and internationally: the NtS Encoding Guide for editors and the NtS Encoding Guide for application developers. These Guides apply to the NtS XSD and the NtS Web Service WSDL as described in Annex 30 and Annex 31 respectively.

Considering increased use of the NtS web service, NtS messages shall be further harmonised to ensure proper display of content on third party systems. Uniform encoding of messages is also a prerequisite for consideration of messages in voyage planning applications.

Elements that would contain only standard or default values shall be omitted if they are conditional, because they lead to message overhead with no added value.

The NtS Encoding Guide for editors is intended for those editing (and publishing) of NtS messages, including step-by-step instructions to create the proper message types as well as an explanation of codes. The NtS Encoding Guide explains the applicability of the four NtS message types, provides filling instructions as well as codes to be used in certain events. The NtS Encoding Guide for editors corresponds to Annex 28.

The NtS Encoding Guide for application developers includes guidelines for NtS application development and implementation, explaining its logic, processes and auto/default values. The NtS Encoding Guide for application developers corresponds to Annex 29.

2. Applicability of NtS messages

An NtS message may relate to object(s) and/or network part(s). Objects are defined in the Reference Data and may be selected by editors upon creation of a message. In NtS messages objects are defined in the 'geo location' section of the NtS XSD.

A network part is defined by a start- and endpoint within the waterway network. There has to be an unambiguous route between the start- and the endpoint which have to lie on the same waterway (only one waterway name is possible between start- and endpoint). In combination with the fairway_name an unambiguous route can be provided (sidearms and potential shortcuts with different fairway_names would be excluded).

If the network_part spans over more than one waterway the NtS editor application may provide functionality to easily select routes or areas to be included within one message.

3. Selection of the NtS message type

a) FTM

Choose this type if you want to create a „Fairway and traffic related message“ for network parts or objects on the waterway (go to paragraph 4).

b) WRM

Choose this type if you want to create a „Water related message“, which enables provision of information on current and forecasted water levels as well as other information. The water related message contains information for an object or a network part (go to paragraph 6).

c) WERM

Choose this type if you want to create a “Weather related message”, which enables provision of information on current as well as forecasted weather situations on a network part (go to paragraph 8).

4. FTM basic considerations, steps towards publication of an FTM

Detailed information which codes have to be used is given in paragraph 5. The considerations beginning from paragraph 4.4 are not necessarily in the input order of an FTM editor tool.

4.1 Is there a need to publish information via NtS FTM according to Part V? All relevant information concerning safety and voyage planning has to be published via NtS messages. Information that is not relevant in terms of safety and voyage planning may be published. Each topic/incident/event has to be published in a separate message.

4.2 Does a valid FTM already exist related to the current situation (related to the content as well as to the time of validity)?

a) Yes:

The already existing FTM has to be updated. The respective published message has to be selected and updated in the FTM editor tool.

An expired FTM cannot be updated any more.

b) No:

A new FTM has to be compiled. In case a similar event is already coded in an existing FTM the respective FTM can be used as draft for the creation of a new FTM (if this function is available), or a template may be used (if this function is available).

4.3 Content of the FTM is to be entered

All information that can be expressed using the NtS Reference Tables has to be coded in the standardised message fields. Only additional information (which is not encodable otherwise) shall be stated in free text fields. The free text shall be kept as short as possible and only include essential information. Per default, the content is provided in the language indicated in the language code in the message identification section. If required, the free text can be provided in several languages. In case content was translated automatically, this is to be indicated together with the text (using a specific attribute 'automated translation').

4.4 The geographical range of validity is to be set

4.4.1 In case the FTM is related to a specific object (e.g. bridge, lock etc.) on the waterway the respective object is to be selected out of the list of available objects (if selection is available).

In case an FTM applies to several objects they can all be included in one FTM.

4.4.2 In case the FTM is related to a specific network part the start- and end points have to be defined (unambiguous route possible between start- and endpoint). If the content applies to several waterways they can all be listed in one FTM including all affected network parts.

4.4.3 Combination of object- and network part related information is possible within one message as long as the information relates to one specific cause/event (same subject and reason code).

4.4.4 The detailed geographic impact of an NtS may be added to the message. It is used for visualisation in web-applications and Apps, and not for navigational purposes.

In case of a `network_part`, it is advised to automatically generate the geographic impact based upon the coordinates (stretch based upon `geo_location_from` and `geo_location_to`).

The `geographic_impact` in the NtS message shall be in line with the information (fairway/waterway coordinates/objects) published in IENCs (in case IENCs are available for the area).

4.5 The limitation section is to be entered if applicable

If limitations are applicable they have to be included in the FTM, as defined in paragraph 5.3.

If values bound to limitations are known they have to be stated. Values for ship dimensions, speed limit and available space for navigation are obliged to be given.

All limitations have to include the limitation periods in order to allow proper calculations within voyage planning applications (to ease the work there might be a function provided by the NtS application to copy limitation periods or to select more than one limitation for a limitation period).

In case the date end of a limitation is known it has to be included in the FTM.

If known also time start and time end of the limitation have to be provided. Especially for blockages, if the date and time end are not known, an estimated end time shall be provided to avoid that short-term obstructions block a route for infinite time.

To communicate to the users that the currently published date end and time end are estimations based upon the actually accessible information for the NtS FTM editor, this shall be indicated by setting the 'end time estimated' to true. Additional information on the estimations may be provided in the free text field.

As soon as more information is available, the message shall be updated including either a new estimate or the correct end time. If the estimate was good enough it is not necessary to update the message. Voyage planning applications consider estimated times for their calculations.

The limitation period of a limitation has to lie within the validity period of an FTM, limitation periods outside the validity period of an FTM are not valid and shall not be taken into account for voyage planning and display to users in applications.

The only exception where it is allowed that a limitation period exceeds the validity period of the message is when a limitation is withdrawn. The limitation is ended by means of the withdrawal date, the limitation periods stay as they were thus may exceed the validity period of the message. Because of the set withdrawal date the limitations are not valid any more. The withdrawn date has to be set to the current time or to the past.

For example, maintenance works on a lock are completed earlier as originally announced. In this case the limitation periods stay as originally announced, only the withdrawn date and time is set to the actual end date of the blockage.

- 4.6 The target group(s) concerning the type of vessels and affected directions is/are to be entered if applicable, as defined in paragraph 5.8
 - 4.6.1 In case the message is valid for all crafts (all types of vessels) in all directions the target group shall be left out in order to only code essential information. If the message/limitation is addressed to a specific target group or direction the respective codes are to be selected.
 - 4.6.2 In case the whole message is valid for specific target groups, the target group information is to be provided in the general part of the FTM (and not repeated in the limitation section(s)).
 - 4.6.3 In case there are different target groups applicable to different limitations the target group information is to be provided within the respective limitations (and not repeated in the general part).
 - 4.6.4 In case exemptions from limitations are granted to individual vessels or local traffic by the competent authorities (e.g. vessels participating in an event for which a general blockage is applicable, local ferry traffic in blocked areas) such exemptions need not be taken into account for coding of the target group(s). Such information may be stated in the free text field for additional information.

4.7 The validity period of the message is to be set.

The start date of the validity of the message is to be set.

The end date of the validity of a message shall be set as well. If it is not already known, an estimate shall be given. The validity end date must not be before the present date. Editors have the obligation to check published messages periodically to set an end date as soon as known or to withdraw messages or limitations that are not applicable any more to ensure that only actual and valid messages are displayed to the users.

Note that the validity period information will be used by applications to select the messages, which are to be displayed to users for a requested time.

4.8 Notice withdrawn

A notice is withdrawn in case a notice was published but it becomes obsolete because

- the announced limitations will not become effective (e.g. dredging was planned but cannot be started due to high water level).
- the announced limitations started but end right away before their original indicated end date (e.g. maintenance works end earlier than originally planned).

In case the entire message is withdrawn before its validity has begun (see Figure 28-1)

- the notice withdrawn flag is set to true.
- the content of the message itself must remain the same, with exception of the validity period. The start and end date of the message are set to present date.
- the withdrawn time has to be filled out for all limitation periods with present date

Figure 28-1
Validity period of FTM not started yet

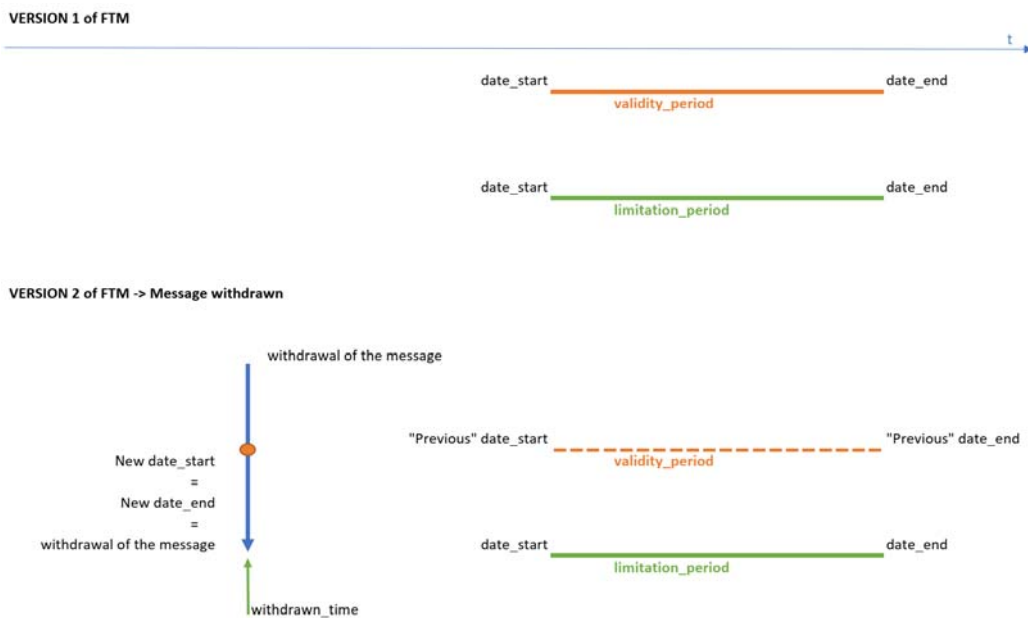

In case the entire message is withdrawn after its validity has begun (see Figure 28-2)

- the notice withdrawn flag is set to true.
- the content of the message itself must remain the same, with exception of the validity end date of the message which is set to present date.
- the withdrawn time has to be filled out for all limitation periods and must not be in the future

Figure 28-2
Validity period of FTM is started

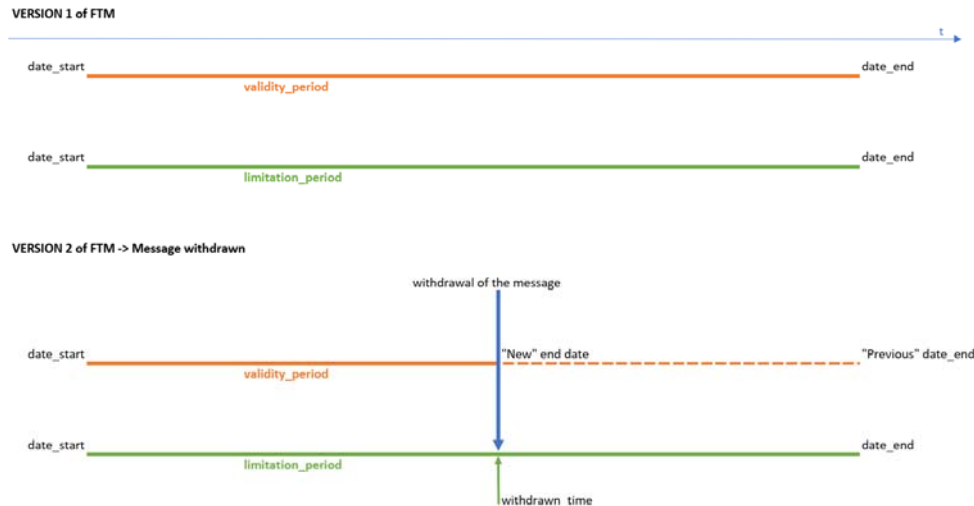

In case individual limitations are withdrawn but other limitations of the message stay valid

- this is an update of the message but not a withdrawal of the entire message;
- the notice withdrawn flag is not included in the message;
- the withdrawn time has to be filled out for limitations that are withdrawn;
- the withdrawn time must not be in the future;
- limitations that stay valid may be updated if there is a change.

If there is another update of the message all previously withdrawn limitations are not provided in the updated message any more. This is to keep the content of the message as small as possible and to only indicate withdrawn limitations compared to the previous message. A history of all withdrawn limitations is not kept inside of the message. As long as the message stays valid the notice withdrawn flag is not included in the message.

4.9 The communication section is to be entered if applicable, as defined in paragraph 5.9.

If additional information is available via a specific source it should be stated in this section. If there is an additional obligation to report via a specific medium it is to be stated in this section.

4.10 The message can be published

5. FTM explanation of codes

5.1 Subject_code:

Definition of use of Subject Codes:

- 'Warning': relevant for safety

The warning must contain at least one limitation that results in direct and concrete endangerment of persons, crafts or facilities, e.g. welding works on a bridge producing sparks, inspection cage/workers hanging from a bridge, obstacle in the fairway,

- 'Announcement': relevant for voyage planning or safety

The announcement may contain limitations, e.g. blockage of a lock chamber due to maintenance works, dredging on the fairway, rules of traffic in addition to national legislation,

- 'Info service': general information that is not directly linked to voyage planning or safety

The info service must not contain specific limitations, therefore it is not directly relevant to voyage planning or safety. Such information might include e.g. local rules of traffic, Inland ECDIS Update.

The validity period is used to specify the time the Info service Message is displayed to the users, not for the period of validity of the provided information (e.g. 1 month or as defined in the national procedures). For 'Info service' a validity end date shall always be set.

5.2 Reason_code

The Reason code should be filled to give additional information to the boatmasters.

Table 28-1
Definition of use of Reason codes

building work	Announcement of construction works
calamity	Warning of a calamity
changes of the fairway	Announcement of changes of the fairway
change marks	Announcement of changes of waterway marks
constriction of fairway	Announcement of a reduced width of the fairway if no other reason_code is applicable
damaged marks/signs	Announcement about damaged marks/signs
diver under the water	Warning about diver under water
dredging	Announcement of dredging works
event	Announcement of events e.g. swimming-, sailing- or rowing competition
exercises	Announcement of exercises e.g. rescue- or military exercises
explosives clearing operation	Announcement of explosives clearing operation

extensive sluicing	Announcement of higher discharge rate as usual through weirs or locks for water management reasons
falling material	Announcement of falling material e.g. icicles, limbs of trees
false radar echos	Announcement of the possibility of false radar echoes
fireworks	Announcement of fireworks
floating material	Announcement regarding floating materials above the water level (visible) and below the water level (invisible)
flow measurement	Announcement of measurement works
health risk	Warning or announcement regarding e.g. through oak processionary caterpillar, leaking gas, etc.
high voltage cable	Announcement of an intersecting high voltage cable
high water	Announcement of a high water situation before the prohibitory water level is reached
ice	Announcement of ice; further information will be sent out via ice-information (Ice-related Message)
Inland ECDIS update	Info service regarding an Inland ECDIS update
inspection	Announcement of inspection works; only used in case of inspection; not used for (repair/building) works. There may be limitations because of inspection cars/cages or scaffolds
launching	Announcement of a vessel leaving a dockyard
local rules of traffic	Info service regarding supplementary or changed rules of valid law or regulation without special limitations, dates of limitations or dates of validity
low water	Announcement of low water situation before the prohibitory water level is reached
lowering water level	Announcement of a controlled lowering of the water level for inspections or works or water management reasons
minimum sluicing	Announcement of lower discharge rate as usual through weirs or locks for water management reasons
new object	Announcement of information regarding a new available object e.g. bridge, berth
obstacle	Announcement of a reduced clearance height and/or reduced width of the fairway because of an obstacle above water level
obstruction under water	Announcement of a reduced available depth and/or for a reduced width of the fairway because of an obstacle under water
prohibitory water level	Announcement of a water level (high water or low water) which causes prohibited navigation

radio coverage	Announcement regarding radio coverage
removal of object	Announcement of removed objects
repair	Announcement in case something is broken or out of order and must be repaired e.g. a lock control system, it can also be used for planned repairs
rising water level	Announcement of natural rising water levels, not because of water management
siltation	Announcement of a reduced available depth because of siltation
sounding works	Announcement of sounding works
special marks	Announcement of the use of special marks e.g. for the blocking from water areas or fishing areas
special transport	Announcement of special transports
strike	Announcement regarding strike of the operating personnel having impact on availability of waterway infrastructure
water level of cautious navigation	Announcement of a water level (high water or low water) by which particular caution for navigation is needed
work	Announcement of general works at objects, at the banks and/or beds of waterways (rivers- or canals)
limitations	Shall only be used as indication for existing limitations if no other reason code is applicable

5.3 Limitation_code:

Definition of use of Limitation codes:

a) blockage:

In case no form of navigation is possible:

- through a lock chamber,
- through a bridge opening,
- through a (flood) gate,
- through a specified point on the waterway,
- on a specified section of the waterway network.

For other individual objects such as berth, terminal the limitation blockage must not be used as it would lead to wrong results of route- and voyage planners (a closed berth does not imply a blockage of the waterway in front of it). In case a berth is closed the limitations 'no mooring', 'no anchoring' or 'no berthing' shall be used.

b) partial obstruction:

The code may be used in case e.g. a lock/bridge is revised and it is not known to the editor which basin of the lock/opening of the bridge is blocked at the given time of the notice so a partial obstruction is valid for the whole lock complex\bridge. In addition the Position_code "variable" can be used. The use of this code shall be reduced to a minimum thus only be used if it is not possible to publish a notice for a specific lock basin or bridge opening.

c) no service:

shall be used in case a movable bridge is not operated during a specified period. This period should be within the normal operating hours.

No service of a movable bridge means that passing under the bridge is still possible. Otherwise it is a 'Blockage'. No service of a lock is to be encoded as 'Blockage'.

d) changed service:

shall be used in case the normal operating hours of objects (e.g. locks, (moveable) bridges) change, are extended or reduced.

e) permissible dimension:

Permissible vessel/convoy dimensions (length, breadth, height, draught) are sometimes to be handled as a pair and not separately. To give an example, the following maximum dimensions for formations might be applicable on a waterway:

- Maximum length: 85 m,
- Maximum breadth: 10.5 m,

OR

- Maximum length: 110 m,
- Maximum breadth: 9.6 m.

This means if a formation has a maximum length of 85 m it may be up to 10.5 m wide, but if the formation is longer (up to 110 m) it may only have a maximum breadth of 9.6 m.

A maximum of the following four limitations may be given in combination with each other:

- length (maximum length of a vessel/convoy),
- breadth (maximum breadth of a vessel/convoy),
- height (maximum height of a vessel/convoy),
- draught (maximum draught of a vessel/convoy).

For permissible dimensions absolute maximum values have to be provided (together with indication_code 'maximum')

f) If there are limitations related to allowed vessel/convoy dimensions (not in direct relation with infrastructure), the limitation is to be encoded with the following codes:

- vessel draught,
- vessel breadth,
- convoy breadth,
- vessel length,
- convoy length,
- vessel air draught.

If available an absolute value shall be provided.

- g) If there are limitations related to available size of an object or a network part, the following codes are used:
- clearance height,
 - available length,
 - clearance width,
 - available depth.
- If available an absolute value shall be provided.
- h) least depth sounded:
shall be used in case depth may cause problems (e.g. due to siltation). A value for the absolute depth (referred to a reference value) shall be provided.
- i) delay:
shall be used in case an obstruction/incident with a limited duration occurs at an object or on a network part between a specified start and end date.
The estimated maximum duration of the obstruction/incident should be encoded. Delay shall not be used in cases when one of several lock chambers of a lock is not available.
- j) navigation in all directions
may be used to indicate that bridge openings or network sections can temporarily be used in both directions (instead of upstream or downstream only). This will support proper voyage calculation, e.g. in case of parallel openings with one-way traffic. If the upstream opening is temporarily blocked, the code 'navigation in all directions' is assigned to the remaining downstream opening.
- k) If specific manoeuvres or actions are prohibited, the respective limitations are to be encoded. These limitations should only be encoded if they are not already announced via navigational signs or regulations that are encoded in the official IENC unless it helps to provide a complete picture of the overall situation:
- minimum power,
 - alternate traffic direction,
 - no turning,
 - no passing,
 - no overtaking,
 - no berthing,
 - no mooring,
 - no anchoring,
 - no wash of waves,
 - speed limit,
 - not allowed to go ashore.
- If available an absolute value shall be provided for speed limit and minimum power.
- l) special caution:
In cases the FTM (or a part of an FTM) is related to a fairway/river/canal/lake an incident occurs. Furthermore it shall be used in cases where it is not possible to describe the limitation in detail but it is helpful or necessary to warn or inform boatmasters that they have to watch out and pay attention to radio information.

m) no limitation:

should only be used in case it shall be explicitly stated that there are no limitations in a certain time period, for example when a lock which is normally used in locking process stands open because the water level at both sides is even.

5.4 Indication_code:

The Indication_code is intended to be used for information about specific values with regard to certain limitations (e.g. speed limit, minimum power, available depth). In order to determine certain dimensions a reference to either an external reference system (geographical or hydrological) (e.g. clearance height, available depth, least depth sounded) or relative to known dimensions of artificial structures (e.g. available length, clearance width) is necessary.

5.4.1 If absolute dimensions or references are known they have to be used because relative values can hardly be taken into account in voyage planning applications. Only if it is not possible to refer to an external reference system relative values should be used.

reduced by → this is a relative value
maximum → this is an absolute value
minimum → this is an absolute value

5.4.2 If the dimension indicating a limitation refers to a geographical or hydrological co-ordinate, the respective reference system has to be indicated in the NtS Message (e.g. clearance height min. 4 m referred to highest navigable water level; available depth min. 1.7 m referred to regulated low water level)

5.4.3 If the dimension indicating a limitation refers to a dimension of an artificial structure (e.g. bridge, lock), the reference may be given relative to known dimensions (e.g. clearance height reduced by 1.5 m, available length reduced by 27 m).

5.5 Position_code (objects):

Wherever possible the Position_code shall refer to the side of the fairway where the object is located relative to the fairway axis (left/middle/right) or other commonly known information (old/new) or geographic direction (north/south/east/west). The position_code for objects may be prefilled automatically from the RIS Index reference data. The left/right side of the fairway is defined looking downstream direction.

5.6 Position_code (limitations):

5.6.1 Wherever possible the Position_code shall refer to the side of the fairway or object where the limitation occurs (left/right). The left/right side of the fairway is defined looking downstream direction.

5.6.2 The Position_code shall direct the attention of the boatmaster to the side of the fairway where e.g. an area of special interest, a danger or an obstacle is located. Therefore a rough indication (e.g. left bank – left – middle – right – right bank) is sufficient. A finer subdivision is not intended.

5.6.3 If necessary, more precise position information should preferably be given by way of maps or sketches (Attachment, see paragraph 4.9)

5.6.4 For network parts where the usual position indication by fairway side (left/right) does not seem appropriate (e.g. harbour basins, certain canal sections without distinct direction of flow) the cardinal points (north/east/south/west) may be used.

5.7 Target_group_code

Table 28-2
Definition of use of Target Group codes

Code	Meaning	Definition
ALL	all	all vessels and convoys
CDG	vessels with dangerous goods	vessel carrying dangerous goods in accordance with the provisions of ADN
COM	commercial vessels	vessels used for commercial activities of cargo or passenger transportation
PAX	passenger vessels	day-trip or cabin vessel constructed and equipped to carry more than 12 passengers
PLE	pleasure crafts	any vessel used for purposes of sports and recreation and not financial gain
CNV	convoys	towed convoy, pushed convoy or side-by-side formation
PUS	pushed convoys	pushed convoy or side-by-side formation
LOA	loaded vessels	vessels used for commercial activities of cargo transportation, with cargo onboard
SMA	small crafts	vessel with a hull less than 20 m long without rudder or bowsprit, except vessels built or equipped to tow, push or propel vessels other than small craft in side-by-side formation and except craft authorized to carry more than 12 passengers, ferry-boats and pushed barges
CND	convoys with dangerous goods	convoys carrying dangerous goods in accordance with the provisions of ADN
MOV	motorised vessels	craft using its own mechanical means of propulsion, except craft whose engines are used only to cover short distances (in harbours or at loading and unloading points) or to make them easier to handle while being towed or pushed
NMV	non-motorised vessels	craft without its own mechanical means of propulsion

5.8 Communication section, as defined in paragraph 4.9

5.8.1 Reporting_code

5.8.1.1 The Reporting_code shall, as a general rule, only be used in case there is a special need for communication (e.g. additional duty to report to local authority with regard to on-site traffic regulation) or where additional information is available (e.g. VHF contact point like channel name or call-sign for current position of dredger) with direct relevance for the FTM.

5.8.1.2 A routine reiteration of publicly available communication data (e.g. telephone numbers of local authorities, VHF channels of locks, etc.) shall be avoided if there is no direct cause for such communication with reference to the FTM.

5.8.1.3 Generally applicable means of communication according to official regulation (e.g. ship-to-ship and ship-to-shore VHF communication as laid down by international, national or regional rules for navigation) shall, as a general rule, not be repeated by the Reporting_code if there is no direct cause for such communication with reference to the FTM).

5.8.2 Communication_code

the following format shall be used for communication information (examples):

- VHF "number, call sign": '10, Schifffahrtsaufsicht Wien'
- Phone or Fax number: '+43123456789, Schifffahrtsaufsicht Wien'
- Internet address: 'https://example.com'
- Sound signalling: 'long blast / langer Ton'
- E-mail: 'example@authority.eu'
- EDI mailbox number: '900012345@edi.bics.nl'
- Teletext: 'ARD, 992 - 995'

5.9 Type_code:

A waterway is either a canal, lake or river.

- anchoring area
- bank
- beacon
- berth
- border control
- bridge
- bridge opening
- buoy
- cable overhead
- canal (The term "canal" is used if a message is relating to the whole canal (not just the fairway))
- canal bridge: aqueduct
- culvert
- distance mark (A distance mark is used to indicate a certain location on the waterway)

- fairway (The term “fairway” means that part of the waterway that can actually be used by shipping).
- ferry
- floating dock
- flood gate (A flood gate is used to protect an area in high water situations)
- harbour
- harbour facility
- harbour master’s office
- lake (The term “lake” is used if a message is relating to the whole lake (not just the fairway))
- light
- lock basin: individual lock chamber
- lock: whole lock complex
- mooring facility
- notice mark
- pipeline
- pipeline overhead
- ramp
- refuse dump
- reporting point
- reservoir
- river (The term “river” is used if a message is relating to the whole river (not just the fairway))
- ship lift
- shipyard
- signal station
- terminal
- tide gauge
- tunnel
- turning basin
- vessel traffic centre
- weir (A weir is used to control the water level in rivers).

6. WRM basic considerations

Water related messages shall, as a general rule, be generated automatically. Where this is not possible the manual generation of WRM shall follow the processes set out for automatically generated WRM (see NtS Encoding Guide for Developers) as closely as possible.

7. Ice related messages basic considerations, steps towards publication of an Ice Message

Ice Messages depend on local observation and assessment and will usually be generated by authorised staff.

An Ice Message shall be issued in case of ice. The ice is not necessarily causing a limitation thus also information about ice not hindering navigation may be feasible. When an ice period is over, an Ice Message containing the ice_condition_code "A" (clear water) may be published. In case there is no ice on the waterway, authorities shall not periodically publish Ice Messages to announce that there is no ice, to limit the amount of published messages.

7.1 Is there a need to publish information via NtS?

The first ice message for a network part or object shall only be published in case of ice at the waterway or tributaries, also in case there are no limitations.

7.2 Does a valid Ice Message already exist for the affected network part or object?

a) Yes:

If a message for the affected stretch is (still) valid the already existing message may be updated. It is possible to update existing ice messages even if the area of applicability changes within a waterway (e.g. ice is expanding increasing the size of affected stretch).

b) No:

In case there is no valid ice message available for the affected stretch, a new message is to be created.

7.3 An Ice Message is always valid for a stretch of the waterway or an object. It is possible to have several stretches or objects in an FTM. The geographical range of validity is to be set by defining the network part.

7.4 The general ice code is to be entered considering the following rules:

7.4.1 General ice code

The general ice code provides an indication whether there are no, small, large, blocking limitations because of ice, allowing to show the ice status in 'traffic light' indications on maps and in tables.

For voyage planning it is required to derive an impact of the ice situation to the voyage plan. In the column "impact on navigation" a proposal for possible impact is made, but this is not shown to the public.

Value	Meaning	Impact on navigation (internal use)
A	navigable	none
B	fairly navigable	reduction of speed by 25 %
C	navigable with difficulty	reduction of speed by 50 %
D	no navigation allowed	blockage

7.4.2 Detailed ice code

The detailed ice code provides additional information on the ice condition.

The detailed ice code is an optional element, with the possibility to add more than one detailed ice code for a network part to inform the end-user as much as possible.

In the NtS Encoding Guide for application developers an affiliation between the General and the detailed ice code is provided. For example, one can only use the detailed ice codes “A”, “B”, “C”, “D” in combination with the general ice code “A”.

7.5 The Ice related FTM can be published. Ice messages will be valid automatically until the next day after publication or until as defined in national procedures.

8. WERM basic considerations

Taking into account the abundance of available Web Services and apps for weather forecasts and weather warnings WERM should only be used for weather information of specific importance for navigation which is not covered by general weather information services.

Weather related messages shall, as a general rule, be generated automatically. Where this is not possible the manual generation of WERM shall follow the processes set out for automatically generated WERM as closely as possible (see NtS Encoding Guide for application developers).

9. Rules for certain elements

9.1 Filling of elements “from”, “publisher” and “source”

- The element “from” includes the name of the system the message was sent from.
- The element “publisher” includes the name of the organisation which published the message.
- The element “source” includes the organisation/department providing the information published in the message.

9.2 Rules for the element “name” related to objects

Object names are usually prefilled by the NtS editor tool based on RIS Index reference data. Names shall be entered in local language, thus also e.g. diacritics or Cyrillic letters may be used. (e.g. Baarlerbrücke, Volkeraksluis or Mannswörth).

Do not include information on characteristics of feature, the type of object shall not be repeated in the name unless additional information to the object type is given.

- E.g.: The lock “Schleuse Freudenu” shall only be named “Freudenau”, the object type “lock” is added automatically based on the type_code.
- E.g.: The object name for the Railway bridge in Krems (AT) is “Eisenbahnbrücke Krems”. The information ‘railway bridge’ is included in the object name as it adds information in addition to the type_code “bridge”.

- E.g.: The object name for a bridge in Linz (AT) is “Nibelungenbrücke”. The word “brücke” stays within the object name as it is part of the bridge name itself.
- E.g.: The waterway gauge “Pegelstelle Wildungsmauer” is named „Wildungsmauer“ as the information that this object is a gauge is already coded in the type_code.

A name of a Distance Mark shall only be given to provide extra information to be displayed to fairway users (for example nautical mile indication). If an object name is given it overrules the general logic that the information displayed to users is a combination of fairway name and fairway hectometre.

- E.g.: At the lower Danube the distance mark at km 1.8 is also the location of the nautical mile 1. The information on the nautical mile may be included in the object name of the distance mark to display it to the users as additional information.

9.3 Rules for the element “name” in the start and end point of a network part

Object names for the start and end point shall only be provided if it provides added value to the users (e.g. name of a bridge where the message applicability starts). For distance marks no object name shall be included unless information on nautical miles (or other relevant information for users) on that specific location shall be given.

9.4 Rules for elements including “object name”, “fairway name” and “route name”

If a name is available / relevant in several languages translations may be provided including the language code in the attribute. This shall be done automatically from the reference data.

E.g. DE: “Staatsgrenze AT-SK”; SK: “Statna hranica AT-SK”.

9.5 Rules for the elements “value” and “unit” within limitations

Unless stated otherwise only cm, m³/s, h, km/h and kW, m/s (wind), mm/h (rain) and degree Celsius are allowed to be used as units within NtS messages. Editors applications may offer different units for the entering of the information and then convert it.

ANNEX 29
NOTICES TO SKIPPERS ENCODING GUIDE FOR APPLICATION DEVELOPERS

TABLE OF CONTENTS

1.	BACKGROUND & STRUCTURE.....	686
2.	APPLICABILITY OF NTS MESSAGES	686
3.	NTS MESSAGES AND SECTIONS	687
4.	WRM BASIC CONSIDERATIONS	688
4.1	FILLING OF NTS_NUMBER SECTION IN THE WRM	688
4.2	FILLING OF WRM INCLUDING FORECASTS	688
5.	ICE RELATED FTM PROCESSES	690
5.1	FILLING OF SUBJECT CODE IN THE ICE RELATED FTM	690
5.2	FILLING OF REASON CODE IN THE ICE RELATED FTM	690
5.3	FILLING OF LIMITATION CODE IN THE ICE RELATED FTM	690
5.4	DEPENDENCIES BETWEEN GENERAL AND DETAILED ICE CODES	691
6.	WERM BASIC CONSIDERATIONS.....	692
6.1	FILLING OF NTS_NUMBER SECTION IN THE WERM.....	692
6.2	FILLING OF WERM 'WEATHER_CATEGORY_CODE'	692
7.	FTM PROCESSES	693
7.1	NEW FTM.....	693
7.2	UPDATE/WITHDRAWAL OF AN EXISTING FTM.....	693
7.3	HANDLING OF FTM LIMITATION GROUPS	695
7.4	AUTOMATIC ORDERING OF LIMITATION CODES	696
8.	GENERAL IMPLEMENTATION RULES.....	697
8.1	FILLING OF THE "NUMBER_SECTION"	697
8.2	FILLING OF ELEMENTS "FROM", "PUBLISHER", "ORGANISATION" AND "SOURCE"	698
8.3	OMISSION OF ELEMENTS	698
8.4	AUTOMATIC FILLING OF DATE_ISSUE.....	698
8.5	HANDLING OF TIME ZONE INFORMATION IN NTS MESSAGES.....	698

8.6	HANDLING OF SECONDS IN NTS MESSAGES	698
8.7	FORMAT OF DECIMALS IN NTS MESSAGES.....	698
8.8	UNITS TO BE USED IN NTS MESSAGES	699
8.9	RULES FOR THE ELEMENT "WATERWAY_HECTOMETRE"	699
8.10	RULES FOR THE ELEMENTS "LOCALISATION_NAME", "LOCATION", "POSITION_CODE" AND "TYPE_CODE"	699
8.11	RULES FOR THE ELEMENT "FAIRWAY_NAME" AND "ROUTE_NAME"	702
8.12	CLARIFICATIONS FOR TRANSLATIONS IN THE SPREADSHEET "REFERENCE_CODE"	702
8.13	RECOMMENDATIONS FOR THE ELEMENT "GEOGRAPHIC_IMPACT"	703
8.14	HANDLING OF TARGET GROUPS	703
8.15	CLARIFICATIONS FOR THE ELEMENTS IN THE "COMMUNICATION_SECTION"	703
8.16	DISPLAY OF VALID MESSAGES AT A GIVEN TIME.....	704
8.17	AUTOMATIC TRANSLATION OF MESSAGE CONTENT	704
8.18	OPTIONAL FUNCTIONS TO INCREASE USER FRIENDLINESS OF NTS EDITOR TOOLS	704
9.	NTS XML MESSAGE STRUCTURE	704
10.	NTS WEB SERVICE.....	704
10.1	OBJECTIVE.....	704
10.2	BASIC PRINCIPLES AND CONSTRAINTS	705
10.3	GENERAL SPECIFICATIONS AND RECOMMENDATIONS	705
10.4	NTS MESSAGE SERVICE (IMPLEMENTATION SPECIFICATION).....	707

Abbreviations

Abbreviation	Meaning
ID	Identifier
NtS	Notices to Skippers
RIS	River Information Services
SOAP	Simple Object Access Protocol
URL	Uniform Resource Locator; location of a network resource typically used for internet addresses
WSDL	Web Services Description Language; standard for the specification of web services
XML	Extensible Markup Language
XSD	XML Schema Definition; standard to specify the structure of XML documents

1. Background & Structure

ES-RIS is continuously being improved. A major step forward was the release of the NtS web service facilitating exchange of NtS messages between authorities as well as between authorities and NtS users.

Two documents have been developed to facilitate the harmonised encoding of NtS messages nationally and internationally: the NtS Encoding Guide for editors and the NtS Encoding Guide for application developers. These Guides apply to the NtS XSD and the NtS Web Service WSDL as described in Annex 30 and Annex 31 respectively.

Considering increased use of the NtS web service, NtS messages shall be further harmonised to ensure proper display of content on third party systems. Uniform encoding of messages is also a prerequisite for consideration of messages in voyage planning applications.

Elements that would contain only standard or default values shall be omitted if they are conditional, because they lead to message overhead with no added value.

The NtS Encoding Guide for editors is intended for those editing (and publishing) of NtS messages, including step-by-step instructions to create the proper message types as well as an explanation of codes. The NtS Encoding Guide explains the applicability of the four NtS message types, provides filling instructions as well as codes to be used in certain events. The NtS Encoding Guide for editors corresponds to Annex 28.

The NtS Encoding Guide for application developers includes guidelines for NtS application development and implementation, explaining its logic, processes and auto/default values. The NtS Encoding Guide for application developers corresponds to Annex 29.

2. Applicability of NtS messages

An NtS message may relate to object(s) and/or network part(s). Objects are defined in the Reference Data. An NtS editor application shall provide capabilities for editors to select such objects upon creation of a message. In NtS messages objects are defined in the 'geo_location' section of the NtS XSD.

A network part is defined by a start- and endpoint within the waterway network. There has to be an unambiguous route between the start- and the endpoint and the geo_location_from and geo_location_to have to lie on the same waterway (only one waterway name is possible between the geo_location_from and geo_location_to). In combination with the fairway_name an unambiguous route can be provided (sidearms and potential shortcuts with different fairway_names would be excluded).

If the network_part spans over more than one waterway, a network_part section for each waterway has to be defined within the same message. An NtS editor application may provide capabilities for editors supporting them in selecting routes or areas an NtS message applies to.

Optionally an unambiguous route can also be defined by providing the `network_part` within the `geographic_impact` section via coordinates in WKT (well-known-text) format.

3. NtS messages and sections

An NtS message consists of the following:

- a) the identification section,
- b) one or more of the following sections according to the message type:
 - limitation(s) for the Fairway and traffic related message,
 - limitation(s) for the Water level related message,
 - weather report(s) for the Weather related message.

Figure 29-1
Visualisation of the NtS message structure

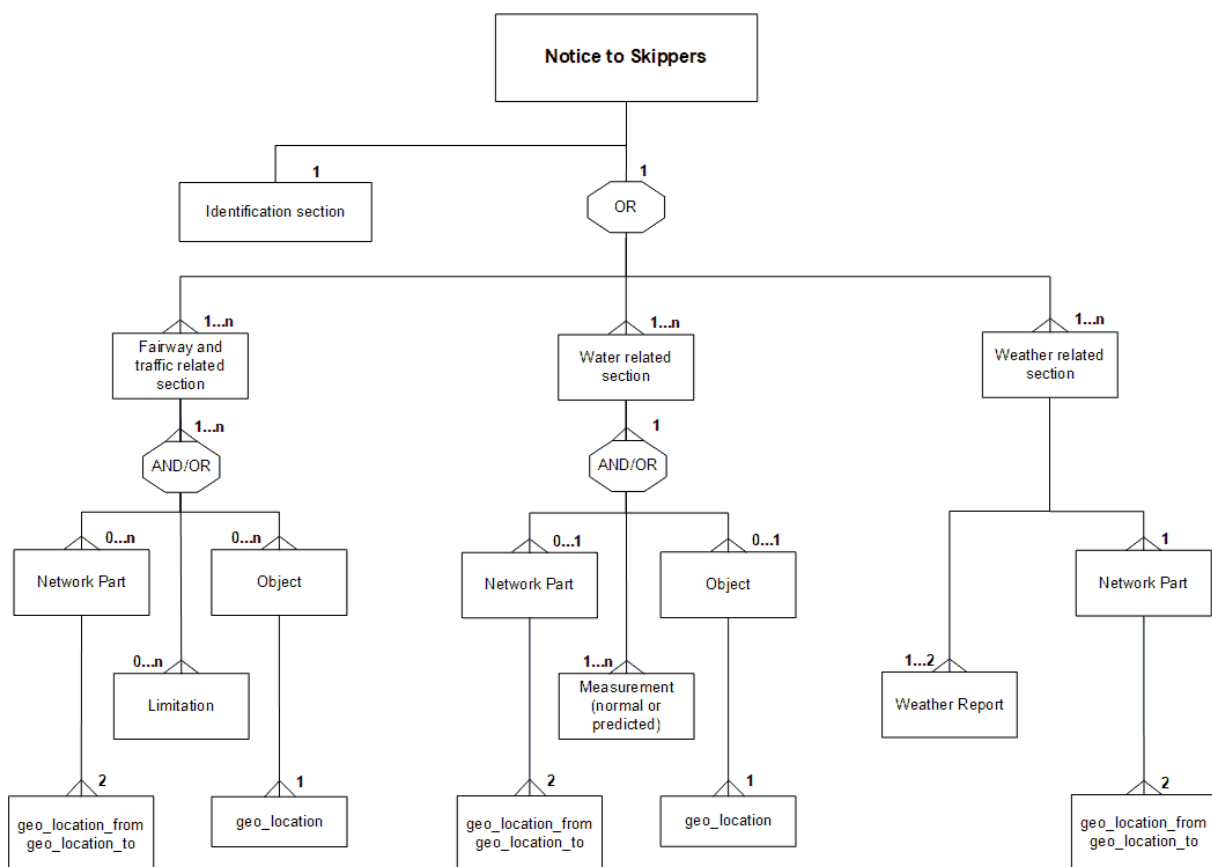

mandatory element (1),

mandatory element that may occur one or two times (1...2),

mandatory element that has to occur two times (2),

mandatory elements that may occur as often as necessary (1-n),

optional element that may occur as often as necessary (0...n).

The identification section includes general information about the message originator, sender, date issue, country and original language and is provided together with one of the four different NtS message section types:

- Fairway and traffic related section: a „Fairway and Traffic related Message“ (FTM) is usually created by NtS editors following the NtS Encoding Guide for editors. It is related to network parts and/or objects on the waterway (go to paragraph 7).

- Water level related section: a „Water Related Message” (WRM) facilitates provision of information on current and forecasted water levels as well as other information. Usually WRM are created automatically (and periodically) based on sensor measurements or infrastructure status not requiring NtS editor interaction. The water related message section contains information for an object (e.g. gauge station) or a network_part (e.g. least sounded depth for a network part, applicable regime at a network part) (go to paragraph 4).
- Weather related section: a “WEather Related Message” (WERM) enables provision of information on current as well as forecasted weather situations on a network part (go to paragraph 6).

4. WRM basic considerations

Water level information is very important for voyage planning as well as safety. At the moment there is no common standard of referencing water level information. The values of gauges are referring to different sea-levels or to special reference points. To provide a proper reference, the respective “reference_code” shall always be provided together with the value. WRM may be used to provide the following information:

- Water level (including forecasts),
- Least sounded depth (including forecasts),
- Vertical clearance (including forecasts),
- Discharge (including forecasts),
- Barrage status,
- Regime.

Clarifications for translations in the spreadsheet “reference_code” are provided in paragraph 8.12.

Usually WRM are created and published automatically based on information received from sensor equipment or information received from infrastructure (e.g. forecasts, barrage status). There may be different triggers for WRM publication, e.g. periodically or when certain values are reached.

4.1 Filling of nts_number section in the WRM

In the NtS XSD described in Annex 30, the NtS number is optional within WRM messages. If it is provided every number has to be unique (Organisation/Year/Number/Serial) per message type and it is up to the organisation providing the WRM to ensure unique numbers (it is not required to have consecutive numbers).

4.2 Filling of WRM including forecasts

The date_start of validity_period has to be filled with present date (date_issue). In order to avoid WRM being displayed to users that are not valid any more, the validity date_end has to be filled automatically by the NtS application with the day after publication.

To provide changes in e.g. water level in a user friendly way the difference to a previous comparative measurement may be provided in the WRM difference section. Besides the change in the value (e.g. -5 [cm]) also the time difference to the comparative measurement has to be provided.

In case of forecasts the “measure_date” is the date/time the forecast is valid for.

Water level forecasts always include a factor of uncertainty. Usually models with different parameters (e.g. weather forecast) are calculated leading to different forecasted water level values. To enable provision of a minimum and maximum forecasted value e.g. visualisation of a water level forecast confidence interval, two additional optional data fields are included in the WRM ‘measure’ section.

An illustration of water level forecast confidence interval is given in the following figure:

Figure 29-2
Visualisation of water level forecast confidence interval

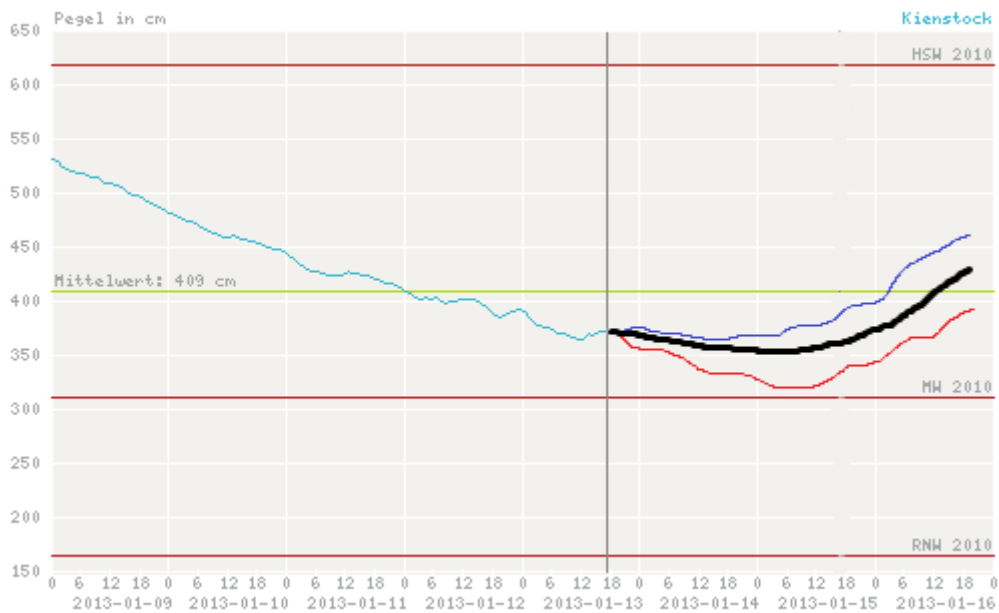

most probable value: black
 confidence interval upper boarder: violet
 confidence interval lower boarder: red

Two elements are available in the NtS XSD:

- <value_min> lowest value of confidence interval,
- <value_max> highest value of confidence interval.

Besides forecasted water levels the confidence interval may also be used to state the uncertainty of published least sounded depth and vertical clearance information.

The confidence interval `value_min` and `value_max` enable provision of WRM value confidence interval via standardised NtS WRM Message to use it in graphs. The raw data itself shall not be displayed to IWT users (e.g. in code format).

5. Ice related FTM processes

Ice Messages depend on local observation and assessment and will usually be generated manually (in case of automatic generation the rules for manual creation have to be followed, see NtS Encoding Guide for editors).

The ice related FTM is published for a certain `network_part` and contains the `ice_condition`.

The validity of the Ice Message starts at the date of publication (automatically set by the NtS application). In order to avoid Ice Message being displayed to users that are not valid any more, the `validity_date_end` has to be filled automatically by the NtS application with the day after publication (unless it is ensured by national processes that messages will get a validity date end as soon as the information included in the message is not up-to-date any more).

In the NtS Encoding Guide for editors it is described under which circumstances an NtS editor creates a new Ice Message or updates an existing Ice Message.

5.1 Filling of subject code in the ice related FTM

In case an ice situation occurs, the reason code "ICE" has to be used.

5.2 Filling of reason code in the ice related FTM

In case the general ice condition code "A" (navigable) is used, the subject code "ANNOUN" is automatically included by the editor application.

In case the general ice condition codes "B", "C" or "D" are used, the subject code "WARNIN" is automatically included by the editor application.

5.3 Filling of limitation code in the Ice related FTM

In case the general ice condition codes "A", "B" or "C" are used, the limitation code "special caution" has to be provided (as limitation code is mandatory).

In case the general ice condition code "D" is used, the limitation code "blockage" has to be provided (as limitation code is mandatory).

In case additional limitations occur on a section, the NtS editors have to add them in additional limitation sections according to the provisions for creation of FTM.

The route impact provided in the NtS Encoding Guide for Editors provides a guideline to the voyage calculation software how to handle the impact of the active General Ice Code, this impact should not be shown in the NtS message.

5.4 Dependencies between general and detailed ice codes

To provide consistent presentation of the ice situation, the general ice code and the detailed ice code shall not provide contradictions. The following table shows possible combinations. NtS applications shall support editors to encode proper Ice related FTM, for example, if the general ice code 'A' is selected, editors can only select the detailed ice codes 'A', 'B', 'C' and 'D'.

Table 29-1
General and detailed ice code combinations

Value		General ice code				
		A	B	C	D	
	Meaning	navigable	fairly navigable	navigable with difficulty	no navigation allowed	
Detailed ice code	A	navigation not yet hindered	X			
	B	navigation conditions may deteriorate rapidly	X	X	X	X
	C	navigation conditions remain constant	X	X	X	X
	D	navigation conditions may improve rapidly	X	X	X	X
	E	inland navigation ports can hardly be reached		X	X	
	F	navigation possible with the aid of ice breakers			X	
	G	no navigation without own icebreaking capabilities			X	
	H	navigation possible in convoy or towage			X	
	I	navigation in convoys compulsory			X	

6. WERM basic considerations

Usually WERM are created and published automatically based on information received from sensor equipment or information received from infrastructure. The `date_start` of `validity_period` has to be filled with present date (`date_issue`). In order to avoid WERM being displayed to users that are not valid any more, the `validity date_end` has to be filled automatically by the NtS application with the day after publication.

A WERM applies to a network part, i.e. area of applicability of the weather station (gauge).

Date and time of measurement/forecast have to be provided.

In case of forecasts the “measure date” is the date/time the forecast is valid for.

6.1 Filling of `nts_number` section in the WERM

In NtS XSD 4.0 the NtS number is optional within WERM messages. If it is provided every number has to be unique (Organisation/Year/Number/Serial) per message type and it is up to the organisation providing the WERM to ensure unique numbers (it is not required to have consecutive numbers).

6.2 Filling of WERM ‘`weather_category_code`’

The wind speed in ‘`weather_category_code`’ (values 0 to 12) shall be provided in line with the Beaufort scale published by the World Meteorological Organization in its Manual on Marine Meteorological Services “WMO-No. 558”.

The visibility in ‘`weather_category_code`’ (values 13 to 22) shall be provided as defined in the following table:

Value, meaning	Visibility	Additional information
13, thick fog	below 50 meters	
14, dense fog	below 100 meters	
15, moderate fog	below 200 meters	
16, fog	below 1000 meters	Fog consists of water droplets.
17, mist	from 1 km to 4 km	Mist consists of water droplets. Mist is used in case of “dry fog”, this phenomenon usually takes place before sunrise.
18, haze	from 1 km to 4 km	Haze consists of dry particles.
19, light haze	from 4 km to 10 km	
20, clear	from 10 km to 20 km	
21, very clear	no limitation of visibility	
22, no fog		“no fog” is used to state that there is no fog depending on national/local requirements.

7. FTM processes

In the NtS Encoding Guide for editors it is described under which circumstances an NtS editor creates a new FTM or updates an existing FTM. The following processes apply:

7.1 New FTM

- a) NtS applications may offer NtS editors to
 - i) use existing notices as draft upon creation of new FTM and/or
 - ii) use notice templates for certain situations.
- b) The content (e.g. time of validity, limitations) has to be entered by the editor in line with paragraph 4 and 5 of the NtS Encoding Guide for editors (Annex 28).
- c) When an NtS editor/publisher triggers the publication action,
 - i) it is checked if all mandatory content is provided in line with the NtS XSD (if not go back to (b)),
 - ii) the `nts_number` is generated by the NtS application,
 - the 'organisation' is filled with the content of the 'publisher' which is included in the identification section,
 - the 'year' is filled with the current year,
 - the next available 'number' is assigned, in case a dedicated number was entered by the NtS editor or an application process in step b) it is taken over (given that (Organisation/Year/Number/Serial) is unique as explained in paragraph 8.1),
 - the 'serial number' 0 is assigned',
 - iii) `date_issue` is automatically filled with the actual date/time of publication action.

7.2 Update/withdrawal of an existing FTM

- a) The respective published message has to be selected to be updated in the FTM editor tool, the original FTM has to be copied or altered in the DB (depending on national processes).
 - i) Expired FTM (which passed the `validity_date_end`) cannot be updated any more, if an update on an incident is nevertheless necessary the NtS editor has to create a new FTM.
 - ii) The "Notice withdrawn" flag is set to "true" when the entire message is withdrawn. The subject code of the previous version must remain the same.

The content of the message itself must remain the same, with exception of the validity period.

 - If the message did not become valid yet the `validity_start_date` and `validity_date_end` have to be set to present date (see Figure 29-3).
 - If the message already became valid the `validity_date_start` remains unchanged and the `validity_date_end` has to be set to present date (see Figure 29-4).

`Notice_withdrawn` is an optional element and must not be included in the message if the notice is not withdrawn.

The element notice_withdrawn is used instead of the subject code “CANCEL” (used in previous editions of the NtS standard). Even if a message is withdrawn the previous subject code (‘announcement’, ‘warning’, ‘information service’) is kept. This makes it possible to display that e.g. a ‘warning’ is withdrawn. The subject code “CANCEL” shall therefore no longer be used for new messages and shall be de-activated in NtS applications.

In addition to setting notice_withdrawn to “true” all individual limitations have to be withdrawn (fill in the withdrawn_time). Present date could be pre-set and changed by editors.

- iii) FTM with “Notice withdrawn” flag set to "true" must not be considered for voyage planning (any more).
- b) The content (e.g. time of validity, limitations) has to be altered by the editor in line with paragraph 4 and 5 of the NtS Encoding Guide for editors (Annex 28).
- c) When an NtS editor/publisher triggers the publication action;
 - i) it is checked if all mandatory content is provided in line with the NtS XSD (if not go back to (b));
 - ii) the nts_number is generated by the NtS application,
 - the ‘organisation’ stays unchanged,
 - the ‘year’ stays unchanged,
 - the ‘number’ stays unchanged,
 - the ‘serial number’ is incremented (increased by 1);
 - iii) ‘date_issue’ is automatically filled with the actual date/time of publication action.

Figure 29-3
Validity period of FTM not started yet

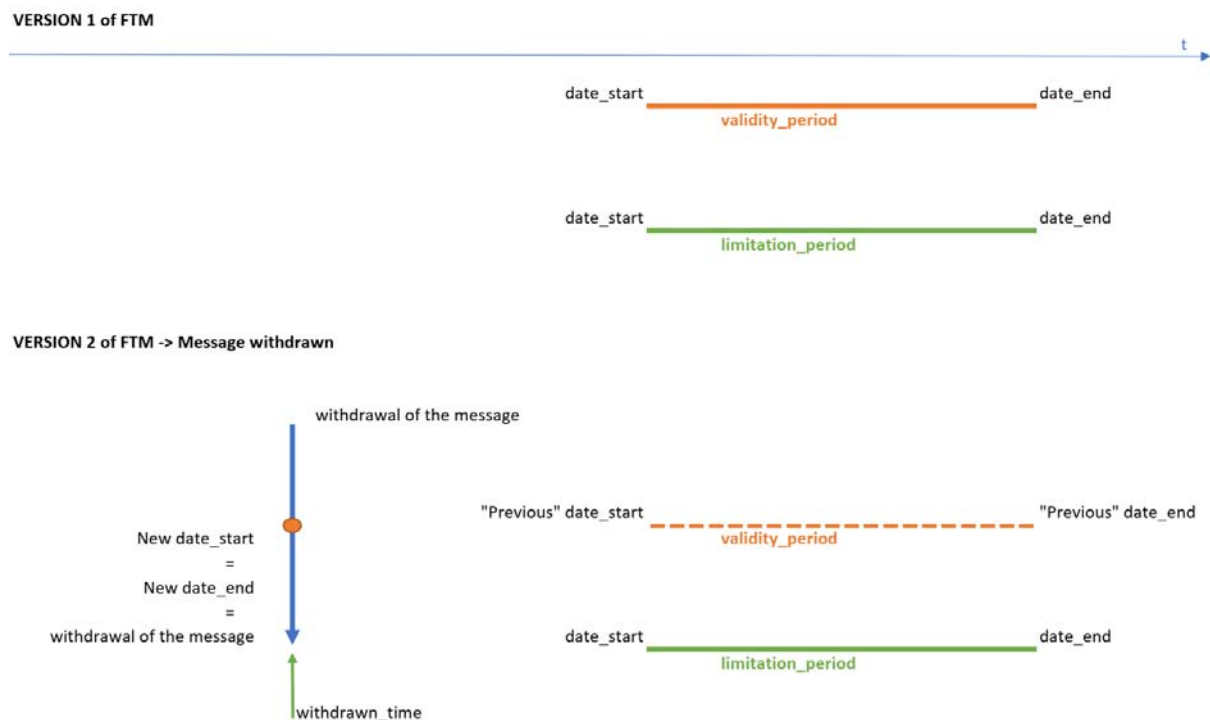
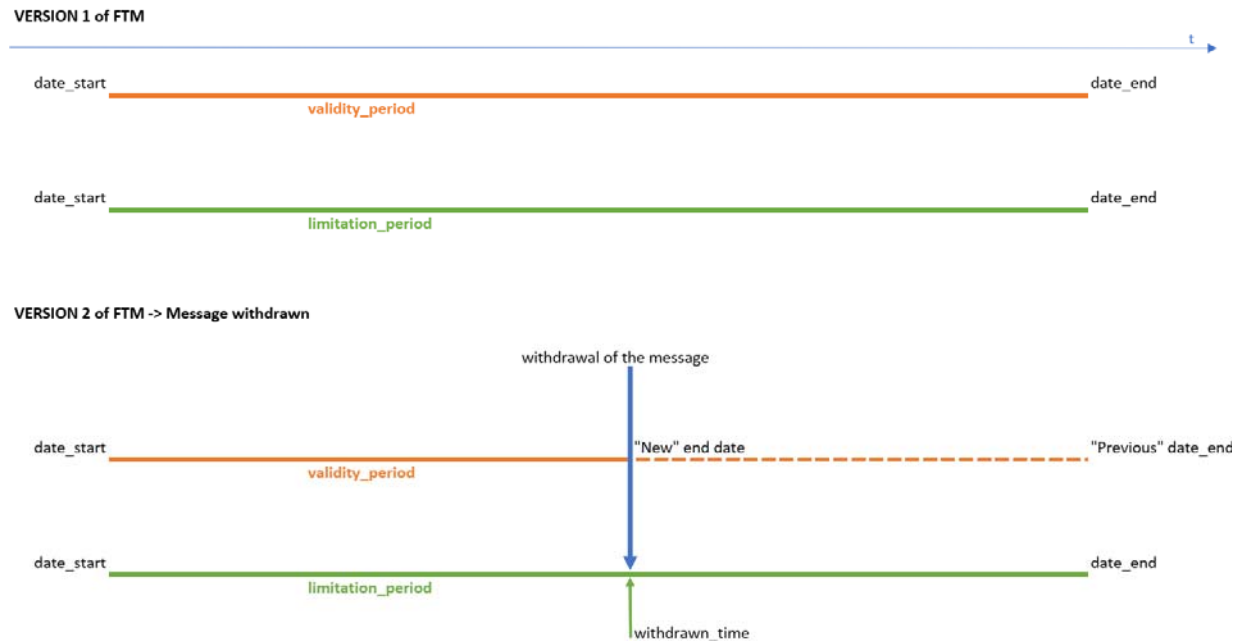

Figure 29-4
Validity period of FTM started



7.3 Handling of FTM limitation groups

- At least one network part or object has to be included in an FTM_limitation_group
- Limitation_groups that apply to different network parts and/or objects have to be included in different FTM_limitation_groups together with the respective network parts and/or objects.
- Limitations that are valid at different limitation periods have to be included in different limitation_groups.
- Limitations with the same limitation periods should be grouped/listed together in one limitation_group to support reader-friendly display.
- All limitations have to include a limitation period in the iCalendar format (RFC 5545).
- The NtS editor tools should provide a function to select more than one limitation code for specific limitation period(s) and automatically create the required limitation groups based on the information entered by the NtS editor.
- The limitation time end always has to be filled in the last version of a message unless the respective limitation is withdrawn and therefore the withdrawn_time is set instead.
- The limitation period of a limitation has to lie within the validity period of an FTM, limitation periods outside the validity period of an FTM are not valid and shall not be taken into account for voyage planning and display to users in applications. In case a limitation is withdrawn the withdrawn_time has to be within the validity period of the message. In this case the limitation date_end and time_end are not considered any more thus may exceed the validity date_end of the message.

- i) When withdrawing a limitation_period, the withdrawn_time must be provided with a timestamp which is either equal to the date of publication of the NtS message or a timestamp which is in the past. It is not allowed to enter a timestamp in the future.
- j) In case several limitations are present in the message but only one of them is withdrawn the content of the limitation_group is to be split in two limitation_groups. One limitation_group ends (and has the withdrawn_time set) and the other one stays valid (no withdrawn_time set).
- k) In case a message is updated and one or more limitations are withdrawn, the withdrawn_time is provided for these limitations. If there is another update of the message all previously withdrawn limitations are not provided in the updated message any more. This is to keep the content of the message as small as possible and to only indicate withdrawn limitations compared to the previous message. A history of all withdrawn limitations is not kept inside of the message.
- l) Depending on the limitation usually no value or exactly one value is provided. The limitation code 'PERDIM' (permissible dimension) is an exception. For 'PERDIM' a minimum of two and a maximum of four values shall be provided together with the dimension_type:
- LEN: length (maximum length of a vessel/convoy),
 - BRE: breadth (maximum breadth of a vessel/convoy),
 - HEI: height (maximum height of a vessel/convoy),
 - DRA: draught (maximum draught of a vessel/convoy).
- The indication_code 'MAX' (maximum) has to be used together with the limitation_code 'PERDIM'.
- The unit (cm) has to be provided together with the limitation_code 'PERDIM'.
- m) All provisions set in this paragraph have to be considered by NtS applications automatically reducing manual editor interactions as much as possible.

7.4 Automatic ordering of limitation codes

Different limitations have different impact on navigation. In order to allow display of the most severe limitation e.g. in an FTM list overview, the following order shall be considered starting with the most severe limitation having Rank 1:

Table 29-2
Order of limitations according to severity

Rank	Value	Meaning
1	OBSTRU	blockage
2	PAROBS	partial obstruction
3	NOSERV	no service
4	SERVIC	changed service
5	PERDIM	permissible dimension
6	VESDRA	vessel draught
7	VESBRE	vessel breadth
8	CONBRE	convoy breadth
9	VESLEN	vessel length
10	CONLEN	convoy length

Rank	Value	Meaning
11	CLEHEI	clearance height
12	VESHEI	vessel air draught
13	AVALEN	available length
14	CLEWID	clearance width
15	AVADEP	available depth
16	LEADEP	least depth sounded
17	DELAY	delay
18	ALTER	alternate traffic direction
19	TURNIN	no turning
20	PASSIN	no passing
21	OVRTAK	no overtaking
22	NOBERT	no berthing
23	NOMOOR	no mooring
24	ANCHOR	no anchoring
25	SPEED	speed limit
26	WAVWAS	no wash of waves
27	NOSHORE	not allowed to go ashore
28	MINPWR	minimum power
29	CAUTIO	special caution
30	ALLDIR	navigation in all directions

8. General implementation rules

The following is to be considered:

- The table "GUI_labels" provided in the NtS Reference Tables shall be considered when building NtS applications (search masks, e-mail subscription form, display of messages).
- The date_end cannot be before date_start.
- Codes that have been disabled (are not to be used any more) via NtS change requests (see comments in the NtS XSD) shall not be displayed to NtS editors upon creation of new messages. The codes are still included in the NtS XSD enumerations for backwards compatibility.

8.1 Filling of the "number_section"

Every number (Organisation/Year/Number/Serial) has to be unique per message type. That means that messages of different types can have the same NtS Number.

For users the message numbers are only relevant for FTM, for all other message types display of the message number can be skipped depending on national requirements.

To users the message number shall be displayed in the following format "Message Type/Country/Organisation/Year/Number/Serial" (it can be shortened depending on applied filters if no information gets lost).

8.2 Filling of elements "from", "publisher", "organisation" and "source"

The element "from" includes the name of the system the message was sent from (e.g. ELWIS, DoRIS, SLOVRIS, VisuRIS).

The element "publisher" includes the name of the organisation which published the message.

The element "source" includes the organisation/department providing the information published in the message.

The element "organisation" within the nts_number section is the name of the "publisher".

8.3 Omission of elements

Elements that would contain only standard or default values shall be omitted if they are conditional, because they lead to message overhead with no added value.

This concerns the following elements:

- Target Group: target_group_code ALL with direction_code ALL (if there are no other specific target groups within the message),
- position_code: AL.

8.4 Automatic filling of date_issue

FTM

For FTM the value of date_issue element is the actual date and time of publishing. In case of updated messages date_issue is the date and time when the update was published.

WRM and WERM

For WRM and WERM the value of date_issue element is the date and time of the processing request, because there can be several measurements with different issuing time stamps within one W(E)RM message.

8.5 Handling of time zone information in NtS messages

Date and time shall always be provided in local time including time zone information within the NtS XML messages.

8.6 Handling of Seconds in NtS messages

As a general rule seconds have to be provided in (date)/time fields but shall not be displayed to NtS users. Minutes are sufficient for NtS granularity.

8.7 Format of decimals in NtS messages

Decimals in numeric fields are indicated with a "." (period). No thousand separators are used.

The number of decimals used for values shall be limited to a feasible amount to ensure user friendly display.

8.8 Units to be used in NtS messages

Only cm, m³/s, h, km/h and kW, m/s (wind), mm/h (rain) and degree Celsius are allowed to be used as units within NtS messages, applications may convert the units for user friendliness.

In case the input units differ from the standardised units the entered values have to be converted by the application accordingly.

8.9 Rules for the element “waterway_hectometre”

The element “waterway_hectometre” includes the position of a location on a waterway. In general this position is deemed to be meaningful to the users thus displayed together with the “type_code” and “object_name” to the users.

For objects of the type “dismar” (distance mark) an object name shall only be given to provide extra information to be displayed to fairway users (for example nautical mile indication). If an object name is given it overrules the general logic that the information displayed to users is a combination of fairway name and fairway hectometre.

8.10 Rules for the elements “localisation_name”, “location”, “position_code” and “type_code”

The element localisation_name is mandatory for objects and optional for network parts. The “object_name” shall be prefilled automatically from the RIS Index reference data “national object name” (NtS editors might amend the prefilled name if this is a national requirement). Naming conventions for object names are included in the RIS Index Encoding Guide version 3.0 or higher. Examples for proper object names are also given in the NtS Encoding Guide for editors.

With more detailed information on each RIS Index object the NtS message contains more information to create a comprehensive visualisation to the end-user, which will look the same for all NtS messages of all authorities.

For RIS Index objects the following attributes are considered and shall be automatically filled from the RIS Index:

- ISRS Location Code;
- Main RIS Index key-attributes in separate fields:
 - Country Code & UN Location Code,
 - Fairway Section Code,
 - Object Reference Code,
 - Fairway Hectometre;
- Object name of the impacted object(s) in one or more languages;
- Location name of the impacted object(s) in one or more languages;
- Object type of the impacted object(s).

The type code is added to the object by the NtS application in front of the object name.

The position of objects is encoded via position code and added to the object by the NtS application out of the RIS Index. Editors may change prefilled type and position codes.

A full object name is composed of its position code, type code and name.

To ease the work of NtS editors the following mapping may be implemented in NtS editor applications supporting editors in finding / selecting the proper objects based on the RIS Index function_code or the NtS type_code:

Table 29-3
Matching, RIS Index function_code' – 'NtS type_code'

Function Code	Function Code Meaning	Type Code	Type Code Meaning
-	-		
BUAARE	E.1.1 Built-Up Areas		to be selected by editor
BUISGL	E.1.2 Building of Navigational Significance		to be selected by editor
brgare	G.1.1 - G.1.6 Bridge Area [C_AGGR()]	BRI	bridge
bridge_5	G.1.1 Bascule Bridge	BRO	bridge opening
bridge_1	G.1.2 Bridges with Bridge Arches	BRO	bridge opening
bridge_1	G.1.3 Fixed Bridge	BRO	bridge opening
bridge_4	G.1.4 Lift Bridge	BRO	bridge opening
bridge_12	G.1.5 Suspension Bridge	BRO	bridge opening
bridge_3	G.1.6 Swing Bridge	BRO	bridge opening
TUNNEL	G.1.7 Tunnel	TUN	tunnel
cblohd	G.1.8 Overhead Cable	CAB	cable overhead
pipohd	G.1.9 Overhead Pipe	PPO	pipeline overhead
bridge_7	G.1.12 Drawbridge	BRO	bridge opening
bunsta	G.3.2 Bunker / Fuelling Station	BUS	Bunker / Fuelling Station
hrbare	G.3.9 Harbour Area	HAR	harbour
hrbbsn	G.3.10 Harbour Basin	HAR	harbour
ponton	G.3.11 Landing Stage, Pontoon		to be selected by editor
morfac	G.3.12 Mooring Facility	MOO	mooring facility
prtare	G.3.15 Port Area	HAR	harbour
refdmp	G.3.17 Refuse Dump	REF	refuse dump
termnl	G.3.19 Terminal	TER	terminal
trm01	G.3.19 RORO-terminal	TER	terminal

Function Code	Function Code Meaning	Type Code	Type Code Meaning
trm03	G.3.19 Ferry-terminal	TER	terminal
trm07	G.3.19 Tanker-Terminal	TER	terminal
trm08	G.3.19 Passenger Terminal	TER	terminal
trm10	G.3.19 Container Terminal	TER	terminal
trm11	G.3.19 Bulk Terminal	TER	terminal
lokbsn	G.4.3 Lock Basin	LKB	lock basin
lkbspt	G.4.4 Lock Basin Part	LKB	lock basin
lokare	G.4.3 / G.4.4 Lock Area [C_AGGR()]	LCK	lock
excnst	G.4.8 Exceptional Navigational Structure	CBR	canal bridge
gatcon_4	G.4.9 Lock Gate	BAR	weir
gatcon_2	G.4.9 Flood Barrage Gate	FLO	flood gate
wtwgag	I.3.4 Waterway Gauge	GAU	tide gauge
FERVRT_2	L.2.1 Cable Ferry	FER	ferry
FERVRT_1	L.2.2. Free Moving Ferry	FER	ferry
feryrt_4	L.2.3. Swinging Wire Ferry	FER	ferry
dismar	L.3.2 Distance Mark along Waterway Axis	DMR	distance mark
achare	M.1.1 Anchorage Area	ANC	anchoring area
achbrt	M.1.2 Anchorage Berth	BER	berth
berths_3	M.1.3 Berth / Fleeting Areas	BER	berth
berths_1	M.1.4 Transhipment Berth	BER	berth
trnbsn	M.4.5 Turning Basin	TUR	turning basin
		CAN	canal
		FWY	fairway
rdocal	Q.2.1 Radio Calling-In Point (notification point)	REP	reporting point
chkpnt	R.1.1 Check Point	BCO	border control
sistat_8	R.2.1 Traffic Sistat – Bridge Passage	SIG	signal station
sistat_6	R.2.2 Traffic Sistat – Lock	SIG	signal station
sistat_10	R.2.3 Traffic Sistat – Oncoming Traffic Indicator	SIG	signal station

Function Code	Function Code Meaning	Type Code	Type Code Meaning
sistat_2	R.2.4 Traffic Sitat – Port Entry and Departure	SIG	signal station
riscen	RIS centre	VTC	vessel traffic centre
trafp	Traffic Points (first reporting points)	REP	reporting point
junction	Waterway node / end of waterway / Junction		to be selected by editor

Legend:

green	Direct match (1:1 relation)
yellow	matching example, other TypeCodes possible (1:n relation)
blue	no direct match / to be selected by editor

8.11 Rules for the element “fairway_name” and “route_name”

To avoid application logic / necessity of proper reference data at the receiving system (software displaying the notice to the user) the element ‘fairway_name’ shall always be included in the network_part or object and automatically filled by the NtS application with the ‘Waterway name’ from the RIS Index. NtS editors shall not alter the content of the element fairway_name.

If the “route_name” is included in the network_part or object it shall be filled automatically from the RIS Index.

8.12 Clarifications for translations in the spreadsheet “reference_code”

The following definition shall be used for reference_code values provided in the NtS Reference Tables:

- NAP: In the Netherlands the abbreviation NAP is used and understood, NAP is not translated
- KP: “channel level” shall be translated thus provided in national language
- FZP: only the abbreviation “FZP” shall be used (nowadays hardly used anymore)
- ADR: “Adriatic Sea” shall be translated thus provided in national language
- TAW/DNG: “Tweede algemene waterpassing” (Dutch) – “Deuxième Nivellement Général” (French) is the reference height used in Belgium to express height measurements. 0 is the average sea water level at low water in Oostende
 - Dutch: TAW,
 - French: DNG,
 - All other Languages: TAW/DNG.
- LDC: “low navigable water level Danube Commission” shall be translated thus provided in national language;
- HDC: “high navigable water level Danube Commission” shall be translated thus provided in national language;
- ETRS: “European Terrestrial Reference System 1989” the abbreviation “ETRS89” is used in all languages.

8.13 Recommendations for the element “geographic_impact”

A polygon consisting of an array of coordinates in WKT (Well-known-text) format may be defined to specify a geographic area for which messages apply.

The geographic impact of an NtS may be added to the message. It is used for visualisation in web-applications and Apps, and not for navigational purposes.

The following coordinate system must be used: WGS 84 latitude/longitude (EPSG:4326).

The geographic impact shall be filled automatically from the reference data and correspond to the area of validity of the FTM message: In case of a network_part, it is advised to automatically generate the geographic impact based upon the coordinates (stretch based upon geo_location_from and geo_location_to).

The geographic_impact in the NtS message shall be in line with the information (fairway/waterway coordinates/objects) published in IENCs (in case IENCs are available for the area).

8.14 Handling of target groups

The target group section consists of target group code and direction code. If both have the value ALL the whole section shall be omitted if there are no other specific target groups within the message. If just one of these two is given the other must be filled with the default value ALL because both elements are mandatory.

Further information concerning target groups can be found in the NtS Encoding Guide for editors.

8.15 Clarifications for the elements in the “communication_section”

The “reporting_code” includes the reporting regime (e.g. if there is an additional duty to report / additional source of information)

The “communication_code” includes the means the reporting takes place (e.g. via VHF, internet)

The “number” includes the information on the address used for reporting (e.g. VHF channel (including callsign), e-mail address, URL). It is possible to provide different numbers for different languages (e.g. different URL for FR, NL or EN version of a PDF)

The “label” includes the information on the name of a communication information, if applicable (e.g. File Name of a PDF). It is possible to provide different labels for different languages.

The “remark” includes additional information on the communication information, if applicable (e.g. Summary of the content of a PDF; call here if you would like to reserve a time slot for locking). It is possible to provide different remarks for different languages.

8.16 Display of valid messages at a given time

The `validity_period` shall be used by applications to select the messages, which are to be displayed to users for a requested time.

If `subject_code` is INFSER (Info service) the validity period is used to specify the time the Info service Message is displayed to the users, not for the period of validity of the provided information (e.g. 1 month).

8.17 Automatic translation of message content

Elements that may be provided in different languages include the attribute language as well as an indication if the content was translated automatically. It is to be included and to be shown to users if text was translated automatically.

8.18 Optional functions to increase user friendliness of NtS editor tools

The following functions may be offered to NtS editors depending on national requirements:

- NtS applications may offer NtS editors to save draft NtS messages (not all mandatory content has to be provided in order to save draft messages),
- Different user roles may apply to different editors (e.g. editors that are allowed to enter/alter notices, publishers that are allowed to publish notices (in addition to editing)).

9. NtS XML Message Structure

The NtS XML Message Structure and the content and purpose of data elements are defined and further explained in Annex 28: NtS XML Schema Definition (XSD).

10. NtS Web Service

10.1 Objective

The NtS Expert Group identified the web service technology as an appropriate means to provide the Notices to Skippers.

This paragraph constitutes the specification of the web service for the provision of the Notices to Skippers, short NtS Web Service.

One goal of the conceptual design was to ensure a good balance between flexibility and robustness of the resulting web service. The filter parameters provided in the requests are essentially the criteria specified in the NtS standard, but focused on machine-to-machine interfacing. This seems sufficiently expressive considering the use cases of the web service and at the same time limits the complexity of the implementation.

The core result is a contract for the web service, in which the requests and responses are specified. The consumers of the web service can rely on this contract and the providers have to comply with it. This contract is specified using the international standard WSDL.

Every participating Member State shall implement one or more web services for the different message types of the NtS (FTM, WRM, WERM) and provide them via the internet ("NtS Message Service").

The technical details of the implementation of the NtS Web Service, e.g. choice of appropriate data pools, applications and platforms, are not in the scope of this specification and are in the responsibility of each individual participating Member State.

In the context of NtS all information are public. So, there is no need to secure the NtS data themselves in terms of data protection. Therefore every provider has to decide on its own in how far this aspect will be implemented in its service.

10.2 Basic Principles and constraints

10.2.1 Web standards

The NtS Web Service has to comply with the Web Services Interoperability Organisation Basic Profile 1.1. This profile provides interoperability guidance for a core set of non-proprietary web services specifications, such as SOAP and WSDL. The most relevant standards herein are

- XML Schema Definition (XSD),
- Simple Object Access Protocol (SOAP) and
- Web Services Description Language (WSDL).

The response message of the NtS Web Service is an NtS message which is defined in XML Schema Definition (XSD) in Annex 30.

SOAP is an application protocol for data transmission among IT-Systems and is standardised by the World Wide Web Consortiums (W3C).

The specific elements for the NtS Web Service are defined inline in the corresponding WSDL specifications in Annex 31. The schema of the NtS standard (XSD) is included with an import statement.

10.3 General specifications and recommendations

10.3.1 Specification: Version information

The version information of the NtS Web Service consists of two sections:

- version of the web service itself,
- version of the NtS schema used by the web service.

The section of the web service itself consists of two parts:

- major version of the web service,
- minor version of the web service.

The major version is given as a positive integer denoting the major version of the web service.

The minor version is given as a non-negative integer denoting the minor version of the web service within the major version.

The section of the NtS schema contains the version of the NtS schema as defined by the NtS Temporary Working Group of CESNI/TI.

Hence, the version of the NtS Web Service specified here is 4.0.6.0, where 4.0 is the version of the web service itself and 6.0 is the version of the NtS schema used.

Explicit version information is not necessary in the requests or responses of the NtS Web Service. There are only a few versions of the services expected to be online at the same time. Different versions shall be provided with different URLs. Hence, each instance of an NtS Web Service implementation shall support one specific version of the NtS Web Service.

10.3.2 Specification: Structure of namespaces

The namespaces in the NtS Web Service are based on the web domain of CESNI/TI: <https://ris.cesni.eu>.

The namespaces contain a particle indicating the corresponding service and version information. Hence, the service specified here uses the following namespace:

NtS Message Service:

https://ris.cesni.eu/_assets/NtS_MS/6.0.6.0/NtS_XSD_V.6.0.6.0.html

10.3.3 Recommendation: Use of namespaces

For higher transparency of XML documents it is recommended to define namespaces in the outmost suitable element in the schemas as well as the instance documents and not to use local namespace definitions in nested elements.

10.3.4 Recommendation: Use of namespace prefixes

Requests and responses in the NtS Web Service shall use XML elements in qualified form, i.e. with an explicit namespace prefix, and XML attributes in unqualified form, i.e. without a namespace prefix.

It is recommended to use intuitive namespace prefixes like “nts” for better human readability.

10.3.5 Definition of the ISRS Location Code

The ISRS Location Code is defined in Part III, Chapter 4, Article 4.03.

10.3.6 Definition of location attributes

Meaningful information with respect to the location of objects shall be extracted from the elements:

- un_locode,
- fairway_section_code,
- object_reference_code,
- fairway_hectometre.

These elements shall be filled automatically by the editor application with information from the RIS Index.

10.4 NtS Message Service (implementation specification)

In this paragraph the implementation specification of the NtS message service is given, deduced from the considerations and choices in the preceding paragraphs.

The NtS message service provides the three types of messages in the NtS:

- NtS FTM (fairway and traffic related message),
- NtS WRM (water related message),
- NtS WERM (weather related message).

An implementation of the NtS message service can support all message types or just a selection. It is allowed that a participating Member State provides more than one service for a specific message type, that complement each other.

10.4.1 Request

In order to achieve a maximum robustness of the service while keeping the complexity on a low level no additional query language is used for the NtS Web Service. Instead the constructs provided by WSDL itself are applied. The specific operations together with their parameters are specified entirely within the WSDL specification. In the case of the NtS Message Service a single operation is defined.

The WSDL allows for a number of filtering parameters, which resemble items of the message. With the filtering parameters it is possible for developers to accurately specify the information they want to provide to the user. There is no need to set up different Web Services for different subjects handled in NtS. A combination of multiple filtering parameters can be defined in the same request. The available filtering parameters are:

- Message Type: The NtS message type allows for filtering between FTM, WRM, or WERM. The Message Type is a mandatory request parameter, only one Message Type can be given in one request.
- Country Code: The two-digit country code allows for filtering of messages concerning a specific country.
- Date Issue: Either a single timestamp or a time span defined by two timestamps (from – to) can be specified for filtering messages, which have been published at a certain date and time (accuracy minutes, no seconds).
 - Provide only one timestamp: request all messages which are published since the given timestamp.
 - Provide two timestamps: request all messages which are published between both timestamps or on the start timestamp.
- Validity Period: Either a single date or a time span defined by two dates (from – to) can be specified for filtering messages, which are valid at a certain date.

10.4.2 Paging mechanism

In order to control the amount of data a paging mechanism must be supported. The paging parameter is defined with a complex type containing the following elements:

- offset: serial number of the first returned message (integer ≥ 0),
- limit: max. number of messages (integer ≥ 0),
- total count: flag, if total number of messages shall be returned (Boolean value).

The complex paging parameter is optional, but if it is present, all elements within have to be given. Then, the paging mechanism works in the following way:

The total number of messages will not exceed the value of the parameter limit, with the exception that a value of 0 means “no limit”. The response skips as many messages as defined in the parameter offset. In order to provide this mechanism, the service has to observe a temporarily stable (but otherwise arbitrary) sequence of the messages, e.g. between two updates of message data on the underlying data set of the web service. This means that two consecutive identical calls must return the same messages in the same order. The parameter total count determines whether the response shall provide the total number of messages matching the subject-specific criteria. Usually it should be sufficient to request this information with the first response, but omit it in all consecutive responses. This should result in a better performance of the web service.

The paging mechanism provides a means to request the messages iteratively in “pages”. In order for the paging mechanism to work properly, the same subject-specific parameters have to be provided in each call.

The number of messages is the maximum number of NtS messages (the container) in the response of the message service. Inside an NtS message, which is the container – the envelope, an FTM, WERM or WRM is present. To have a good control over the paging mechanism, one WERM or WRM shall be provided inside the NtS envelop (according to the standard, it's prohibited to add more than one FTM in an NtS envelope).

If f.e. 100 WRM messages are inside one envelop, the sending and receiving system, do not have control over the paging and the size of the response message. And if the sending system want to control the size of the response, it would have to cut NtS messages in different parts (according to the amount of the “limit”) and this way edit official send out messages, which could cause operational and possibly legal problems.

10.4.3 Response

In case of a successful request the NtS Web Service response contains the NtS messages that match the request parameters. The NtS messages have to comply with the NtS schema and can be validated against that schema. Since the message type is a compulsory request parameter, each response can contain only NtS messages of the same message type, FTM, WRM or WERM respectively.

The result is ordered ascending on the date_issue.

10.4.4 Error Handling

If the service detects errors while processing the request it can return an arbitrary number of error messages, using the error codes listed in the following subparagraph.

One response of an NtS Web Service can contain NtS messages and error messages at the same time.

In the paging information the offset and number of contained messages are mandatory, the total count needs only be present if it has been requested.

Please note: It is assumed that the communication between the web service and the user is technically established, i.e. the service receives the request and the user receives the corresponding response. Technical errors, e.g. breakdown of the internet connection or inaccessibility of the web service due to maintenance or crash, are not considered here. Only error situations that happen "behind" the web service layer from the users point of view are considered here.

10.4.5 Error messages

The error codes for the expected error situations are given below, together with an explanation. The error code together with the description is contained in the response.

Table 29-4
Error codes for the NtS message service

Code	Description	Explanation
e010	message type not supported	web service does not support the requested message type
e030	paging parameters inconsistent with messages	parameters for paging mechanism do not fit the available messages, e.g. Offset \geq Total Count
e100	syntax error in request	request violates the schema for requests; can be specified in more detail by further e1xx-Codes
e110	incorrect message type	given message type is not known
e130	incorrect paging parameters	given parameters for the paging mechanism are erroneous
e140	country not supported	web service does not provide messages for the requested country
e200	operation not known	the requested operation is unknown
e300	data source unavailable	data source of the web service for the NtS data is temporarily unavailable (technical problem)
e310	too many results for request,	server is unable to handle number of results

ANNEX 30
STANDARDISED NOTICES TO SKIPPERS EXTENDED MARKUP LANGUAGE
(XML) SCHEMA DEFINITION(XSD)

Appendix 1 NtS, XSD file (source code) (Distributed separately)

ANNEX 31
NOTICES TO SKIPPERS WEB SERVICE SPECIFICATION (WSDL)

Appendix 1 NtS, WSDL (Distributed separately)

***ANNEX 32-
NOTICES TO SKIPPERS REFERENCE TABLES (TAGS)***

Appendix 1 NtS reference tables (Tags) (Distributed separately)

